



Current Tools

FOR THE PROFESSIONAL ELECTRICIAN

**Current Tools™ Model #100
10,000 lb. Capacity
Mobile Cable Pulling Package**

Patent Pending

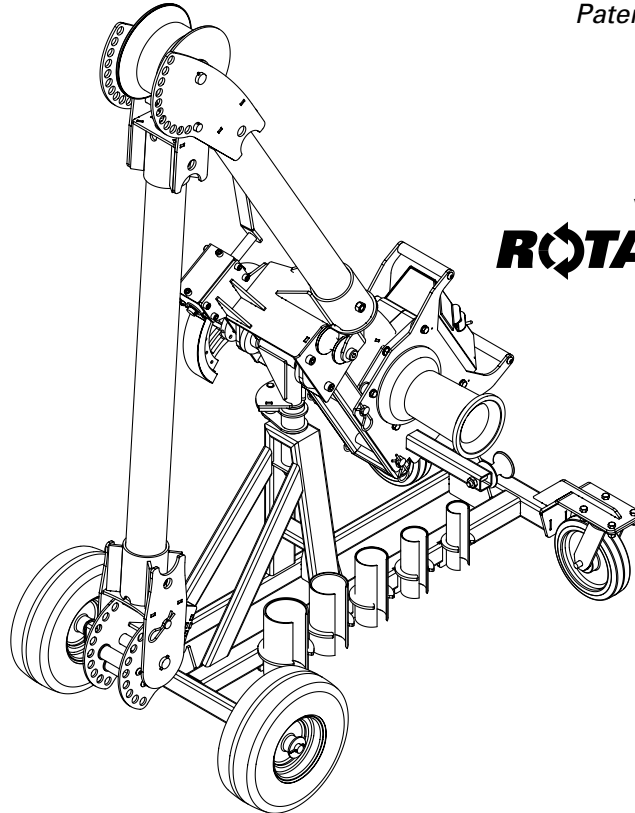

with
ROTABOOM™

Operating, Maintenance, Safety and Parts Manual



Read and understand this material before operating or servicing the Cable Puller or any component of the Cable Pulling Package. Failure to understand how to safely operate and service these units may result in serious injury or death.

10/2016

This manual is free of charge. All personnel who operate the Cable Puller or any component of the Cable Pulling Package should have a copy of this manual and read and understand its contents. To request a copy of this manual or replacement safety decals, or for technical assistance, call, write to the address below or visit our website.

**CURRENT TOOLS • P. O. BOX 17026 GREENVILLE, SC 29606
800.230.5421 or 864-721-4230 • FAX 864-721-4232
www.currenttools.com**



TABLE OF CONTENTS

<i>Safety Alerts</i>	3
<i>Important Safety Information</i>	4-7
<i>Major Components</i>	8
<i>Grounding Instructions</i>	9
<i>Assembly Instructions</i>	10-15
<i>Common Set-Ups</i>	16
<i>Transport Information</i>	17
<i>Floor/Chain Mount</i>	18-22
<i>Specifications and Features</i>	23-24

MODEL 1450 CABLE PULLER

<i>Cable Pulling Basics</i>	25, 26
<i>Operating Instructions</i>	27-30
<i>Maintenance</i>	31
<i>Exploded Views and Parts Lists — Model 1450</i>	32-35
<i>Wiring Diagram — Model 1450</i>	36
<i>Components Parts Listing</i>	37-41



Safety Alert Symbol

THIS SAFETY SYMBOL is used to call your attention to instructions that concern your personal safety. It means: ATTENTION! BE AWARE! THIS IS AN IMPORTANT SAFETY INSTRUCTION!

Read, understand, and follow these safety instructions. Failure to follow these safety instructions may result in injury or death.

DANGER

Immediate hazards which, if not avoided, WILL result in serious personal injury or death.

WARNING

Hazards or unsafe practices which, if not avoided, COULD result in serious personal injury or death.

CAUTION

Hazards or unsafe practices which, if not avoided, COULD result in minor personal injury or property damage.

RETAIN SAFETY INFORMATION



This manual should be read and understood by all personnel who operate or service this Puller. Failure to understand how to safely operate and service this unit could result in serious injury or death. This unit should only be operated and serviced by qualified personnel.



IMPORTANT SAFETY INFORMATION

- ⚠ DANGER** DO NOT operate cable puller in wet or damp locations. DO NOT expose to rain.
- ⚠ DANGER** DO NOT operate in an explosive atmosphere.
- ⚠ DANGER** DO NOT use cable puller as a hoist or for lifting, supporting or transporting people or loads. Use only for its intended purpose as a cable puller.
- ⚠ WARNING** DO NOT wrap rope around any body parts. DO NOT wrap rope around wrists.
- ⚠ WARNING** ALWAYS keep rope away from operator's feet.
- ⚠ WARNING** DO NOT exceed load rating of cable puller, rope, or accessories.
- ⚠ WARNING** ALWAYS inspect rope before each use.
- ⚠ WARNING** ALWAYS disconnect cable puller before servicing.
- ⚠ WARNING** ALWAYS plug the Model 1450 Cable Puller into a grounded receptacle with a 20 amp GFCI protected circuit. DO NOT modify the plug provided with the Model 1450 Cable Puller.
- ⚠ WARNING** ALWAYS inspect the structural integrity of any supports, conduit, anchoring system etc. that will hold the cable puller during the pull. These supports should be able to withstand the maximum pulling force of the cable puller plus a safety factor of 3:1. Example: 10,000 lb. puller should be anchored to a support that can withstand 30,000 lbs. of pull.
- ⚠ WARNING** When using the Model #2280 floor mount or Model #2281 chain mount, ALWAYS ensure the cable puller is properly pinned onto the floor/chain mount and that the floor/chain mount is properly secured before operating. ALWAYS attach the Model #2281 chain mount to supports that are at least 2" and not more than 10" wide. See Figure 4
- ⚠ WARNING** DO NOT mount the Model #2281 floor/chain mount to square columns or I-Beams. The mounting chains will not tighten properly on these structures.

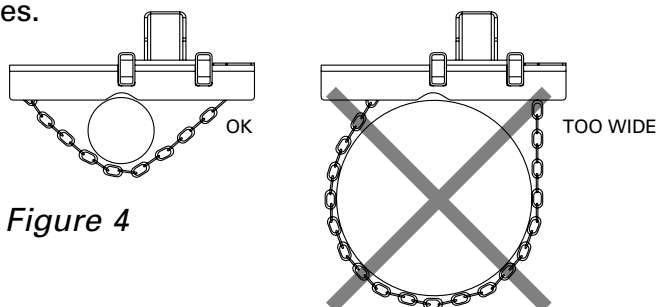

Figure 4



IMPORTANT SAFETY INFORMATION — CONTINUED

- ▲ WARNING** Pulling Rope should be the only thing to contact the capstan. NEVER let swivels, grips, etc. come in contact with the capstan.
- ▲ WARNING** Keep as much rope confined in conduit as possible. This will help prevent injury should the rope break and whip violently.
- ▲ WARNING** Rope must ALWAYS be pulled over a rotating sheave. If a sheave does not rotate, turn cable puller off immediately and determine problem before continuing the pull.
- ▲ WARNING** This cable puller is equipped with an anti-reversing pawl. The pawl will make a clicking sound when the capstan is rotating. If you can not hear the clicking sound as the capstan rotates, immediately turn the cable puller off and do not use until repaired.
- ▲ WARNING** ONLY use 7/8" diameter or larger double-braided composite pulling rope with a minimum average breaking strength of 32,000 lbs.
- ▲ WARNING** NEVER allow the rope to slip on a rotating capstan for more than a couple of seconds. The rope will wear in that spot and the rope could break under pressure. If you need to stop the pull, turn the cable puller off and tie the rope off to hold it in place until you restart your pull.
- ▲ WARNING** Keep all body parts, hair, loose clothing, etc. away from rotating parts and pinch points. Keep hands away from capstan.
- ▲ WARNING** NEVER allow the rope to overlap on the capstan. If this condition begins to occur, immediately release the tailing force on the rope so that the rope can feed back toward the conduit or cable tray. If this does not remedy the overlap, turn off the cable puller immediately. **There is no known solution for rope overlap.**
- ▲ WARNING** Some components of the mobile cable pulling package exceed 50 lbs. and will require more than one person to lift, transport and assemble.
- ▲ WARNING** ALWAYS inspect pins to be sure they are the correct part number for the assembly and are fully inserted through holes and have spring clips properly attached. DO NOT substitute any other object for factory supplied pins.
- ▲ WARNING** The pulling rope must come in contact with ALL the sheaves used in the boom system. This includes the elbow unit sheave when the elbow unit is installed.
- ▲ WARNING** When making a vertical cable pull, keep the area underneath the cable pull clear of all personnel.
- ▲ WARNING** ALWAYS ensure the factory supplied boom tubes are fully inserted into the receiver tubes and that the spring loaded boom pins are fully engaged in the boom tube holes. When using boom tubes other than factory supplied, ensure they are fully inserted into the receiver tubes (sight holes are provided to ensure tubes are fully inserted) and 1/2-13 x 2" hex head cap screws (not provided) are installed and tightened against the tubes. DO NOT transport the puller on the carriage with boom tubes longer than the factory supplied 3' and 4' tubes.

IMPORTANT SAFETY INFORMATION — CONTINUED

▲ WARNING Rope should approach capstan as shown in Figure 6a

▲ WARNING ALWAYS use black roller to guide rope so that the operator stands at a 90° angle to the cable puller and out of the direct line of tight pulling rope. See Figure 6b.

▲ WARNING ALWAYS wrap rope beginning at housing end of capstan as shown in Figure 6b.

▲ WARNING To help avoid rope overlap, rope should approach capstan at 90° angle. See figure 6b.

▲ CAUTION DO NOT switch between low and high speeds while the foot pedal is depressed.

▲ CAUTION ALWAYS make sure the puller motor has completely stopped before switching from low to high speed or high to low speed.

▲ CAUTION DO NOT alter this cable puller. Doing so will void the warranty. Guards and safety features are provided for your protection.

▲ CAUTION DO NOT use an extension cord longer than 100 ft. Extension cord should be a minimum of 12 gauge wire with ground.

▲ CAUTION Wear eye protection when operating cable puller.

▲ CAUTION Inspect all components of the pulling system before beginning any cable pull. This includes the pulling system (cable puller, boom, etc.) and any accessories (sheaves, swivels, pins, etc.) Replace any worn or defective components.

▲ CAUTION Be careful during assembly and disassembly of the boom components. Keep pins in place to avoid uncontrolled movement of boom components. Have control of boom components before removing any pins.

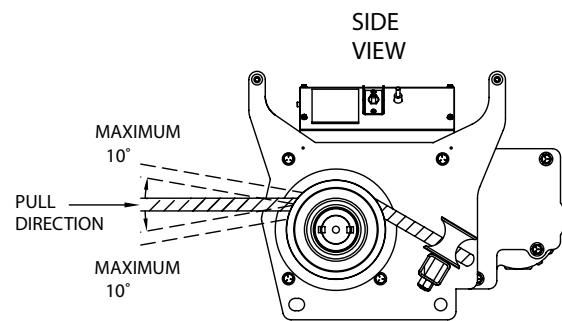

Figure 6a

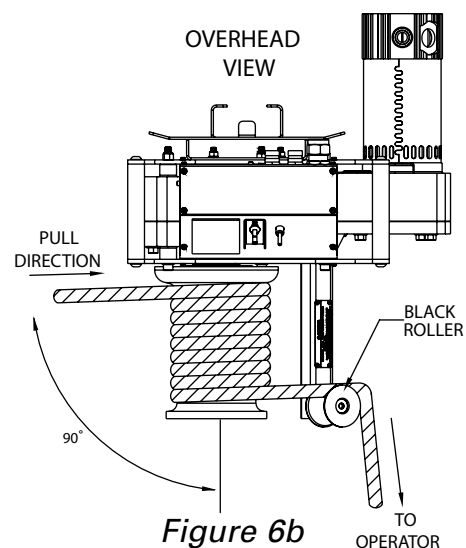
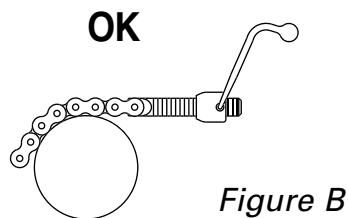
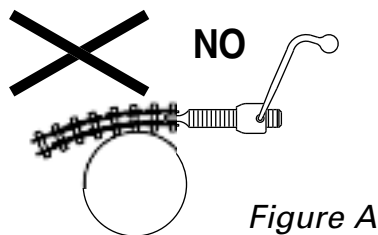

Figure 6b

! WARNING

When using the Model #2281 chain mount, never tighten chain as shown in Figure A. This causes side loading of the chain and can result in failure of the chain or screw causing components to come loose and possibly cause serious injury or death. Figure B shows the proper alignment of screw and chain for tightening.



! WARNING

When using one boom tube and nose unit, factory supplied boom tube may be replaced but must meet the following specifications:

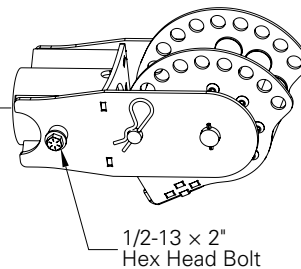
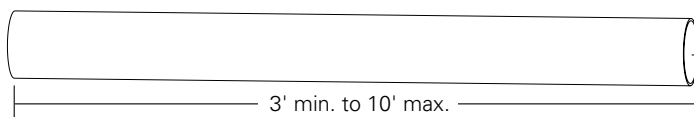

- Only use 3" schedule 40 pipe or 3" rigid conduit
- Check sight holes to be sure boom tubes are fully inserted. Then tighten 1/2-13 x 2" hex bolt (user provided).
- DO NOT transport the puller on the carriage with boom tubes other than the factory supplied 3' and 4' tubes.

When using elbow unit, nose unit and both boom tubes, factory supplied boom tubes may be replaced but must meet the following specifications:

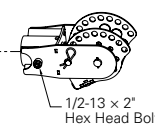
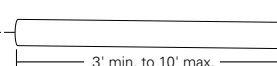
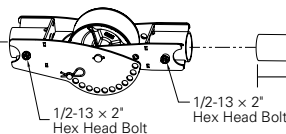
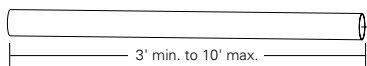

- Only use 3" schedule 40 pipe or 3" rigid conduit
- Check sight holes to be sure boom tubes are fully inserted. Then tighten 1/2-13 x 2" hex bolt (user provided).
- DO NOT transport the puller on the carriage with boom tubes other than the factory supplied 3' and 4' tubes.

MAJOR COMPONENTS — MODEL #100

ITEM #	CATALOG #	DESCRIPTION	WEIGHT
1	1450	Cable Puller – 10,000 lb Capacity	119 lbs.
2	1710	Elbow Unit	43 lbs.
3	1840	Nose Unit	33 lbs.
4	1000	Mobile Carriage	75 lbs.
5	1190	Puller Mount	89 lbs.
6	1850	Boom Tube – 36" Long	13 lbs.
7	1860	Boom Tube — 48" Long	17 lbs.
8	198	Coupling – 2"	1.6 lbs.
9	199	Coupling – 2 1/2"	1.9 lbs.
10	200	Coupling – 3"	2.4 lbs.
11	201	Coupling – 3 1/2"	3.8 lbs.
12	202	Coupling – 4"	4.3 lbs.
13	230	Coupling – 5" (optional)	4.8 lbs.
14	255	Coupling – 6" (optional)	5.5 lbs.
15	2280	(optional) Floor Mount and four 5/8" X 6" wedge anchors	40 lbs.
16	2281	(optional) Chain Mount with chains	50 lbs.
17	259	(optional) Screw-on Coupling – 2"	2.1 lbs.
18	260	(optional) Screw-on Coupling – 2 1/2"	2.4 lbs.
19	261	(optional) Screw-on Coupling – 3"	2.9 lbs.
20	262	(optional) Screw-on Coupling – 3 1/2"	4.3 lbs.
21	263	(optional) Screw-on Coupling – 4"	4.8 lbs.

MAJOR COMPONENTS LIST — MODEL #100

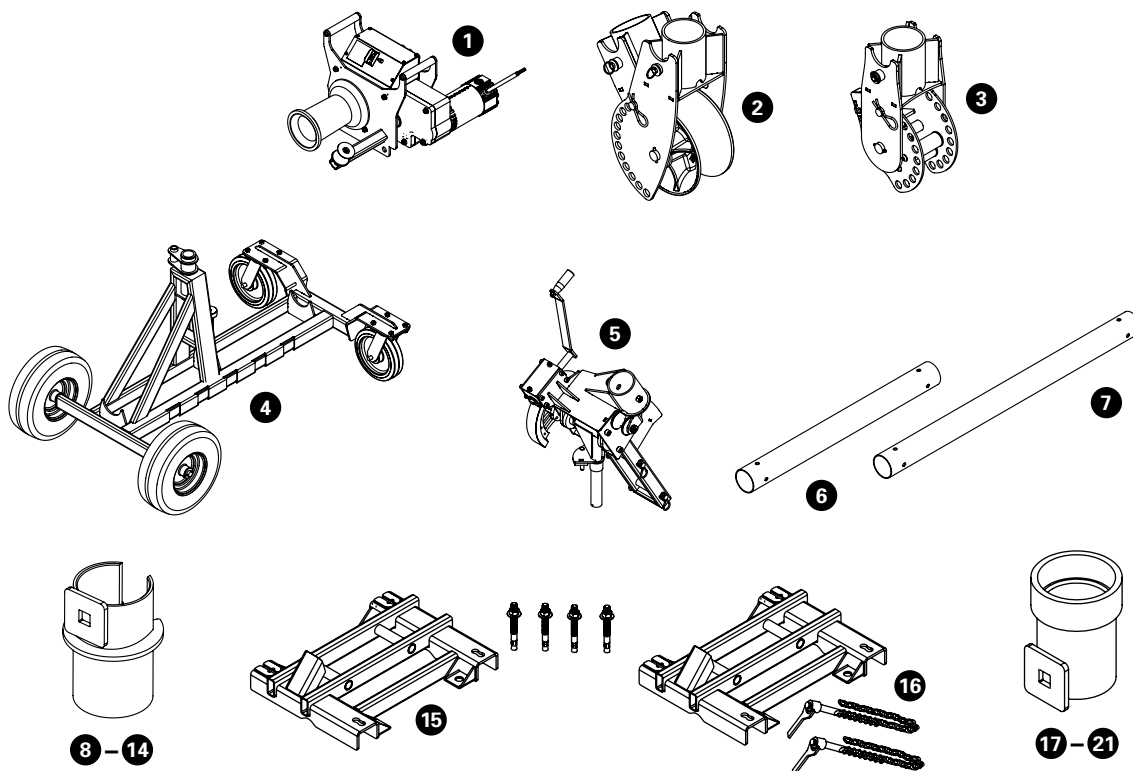

GROUNDING INSTRUCTIONS

WARNING

ELECTRIC SHOCK HAZARD! Only connect the Model 1450 Puller to a 20 amp GFCI protected circuit. **DO NOT** modify the plug that is provided with the unit. Failure to follow these warnings can result in serious injury or death.

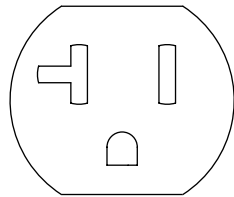

RECEPTACLE

Figure 9

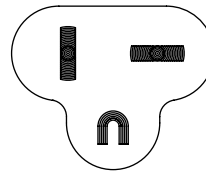

PLUG

Figure 9A

In the event of a malfunction or breakdown, grounding provides a path of least resistance for electric current to reduce the risk of electric shock. The Model 1450 puller is equipped with an electric cord having an equipment grounding conductor and a grounding plug. Only connect the Model 1450 puller to a 20 amp GFCI protected receptacle which is properly installed and grounded to meet all applicable electrical codes. **DO NOT** use an adapter.

DO NOT modify the plug provided. If it will not fit the receptacle, have the proper receptacle installed by a qualified electrician.

Improper connection of the equipment grounding conductor can result in risk of electric shock. The conductor with insulation having an outer surface that is green with or without yellow stripes is the equipment grounding conductor. If repair or replacement of the electric cord or plug is necessary, do not connect the equipment grounding conductor to a live terminal.

Check with a qualified electrician or service personnel if the grounding instructions are not completely understood, or if in doubt as to whether the Model 1450 Puller is properly grounded.

Use only 3-wire extension cords that have 3-prong grounding plugs and 3-pole receptacles that accept the Model 1450 puller's plug.

Repair or replace damaged or worn cord immediately.

This puller is intended for use on a circuit that has a receptacle that looks like the one illustrated in Figure 9 above. The puller has a grounding plug that looks like the plug illustrated in Figure 9A above.

ASSEMBLY INSTRUCTIONS

Planning the Pull

WARNING

Some components weigh more than 50 lbs. and will require more than one person to lift, transport and assemble.

1. Referring to the major components list on page 8 make sure you have all the components necessary to build a complete package.
2. Plan the pull to determine which components you will need.

Coupling Selection

The nose unit of the puller package is connected to the conduit using Current Tools slip-in couplings or optional screw on couplings. From the information in this section, choose and install a coupling that will meet your pulling requirements.

Slip-In Couplings

Slip-In Couplings are provided for conduit sizes 2", 2 1/2", 3", 3 1/2" and 4". 5" and 6" couplings are available as an option.

Slip-In Couplings Procedure:

1. Match the coupling to the conduit size.
2. Install the correct size slip-in coupling into the coupling adapter located in the nose unit by inserting the receiver plate into the coupling adapter until the spring loaded pawl "snaps" into place. See Figures 10a through 10d.



10a



10b



10c



10d



NOTE: To disassemble couplings from coupling adapter, pull the ring on the back of the coupling adapter. This will retract the spring loaded pawl and release the coupling.

10e

ASSEMBLY INSTRUCTIONS — CONTINUED

Slip-In Couplings Used to Straddle Conduit

Slip-In Couplings can be used to straddle the conduit. One advantage of this is the couplings can be straddled on conduit sizes smaller than 2 1/2". However, the largest conduit you can straddle using a slip-in coupling is 5" (by using the 6" optional slip-in coupling).

When using a slip-in coupling to straddle the conduit, the coupling must seat against a concrete floor or similar structure capable of supporting 10,000 lbs. of force.

Slip-In Couplings Used to Straddle Conduit Procedure:

1. Choose a coupling that is at least 1" larger than the conduit.
2. Place the coupling over the conduit. The conduit must NOT extend past the end of the coupling. (See Figure 11a).

WARNING

Bottom of coupling must be seated against a structure capable of supporting 10,000 lbs.

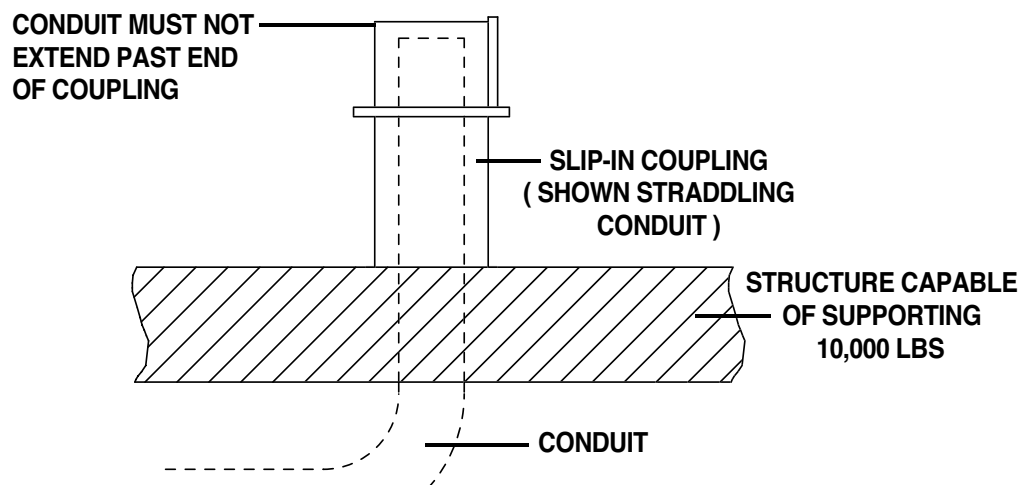

Figure 11a



Screw-On Couplings

Screw-On Couplings, which thread onto the end of Rigid or IMC conduit, are optional for conduit sizes 2", 2 1/2", 3", 3 1/2" and 4".

Screw-On Couplings Procedure:

1. Match the coupling to the conduit size.
2. Thread coupling onto the conduit until tight. Then, slightly back off coupling until the coupling receiver plate faces the direction where the puller will be positioned. See Figure 12.
3. Install the correct size coupling into the coupling adapter located in the nose unit by inserting the receiver plate into the coupling adapter until the spring loaded pawl "snaps" into place. See Figures 10a through 10d.

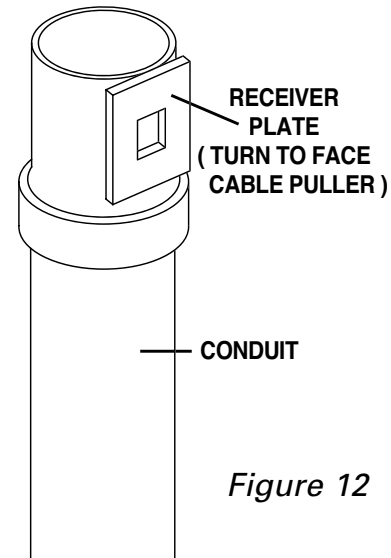

Figure 12

! WARNING

NOTE: To disassemble couplings from coupling adapter, pull the ring on the back of the coupling adapter. This will retract the spring loaded pawl and release the coupling. (See Figure 10e).

! WARNING

Thread Screw-On Coupling onto conduit a minimum of 4 full turns. Inspect the conduit threads to make sure they are in good condition.

! WARNING

DO NOT use screw-on couplings when pulling in PVC conduit. Screw-on couplings may detach and cause serious injury or death. When pulling in PVC conduit, ONLY use slip-in couplings.

ASSEMBLY INSTRUCTIONS — CONTINUED

Boom Assembly

! WARNING

ALWAYS inspect pins to be sure they are fully inserted through holes and have spring clips properly attached. DO NOT substitute any other object for factory supplied pins.

! WARNING

ALWAYS check sight holes to ensure boom tubes are fully inserted into receiver tubes. Ensure all spring loaded boom pins snap into place to securely hold the boom tubes.

! WARNING

Some components weigh more than 50 lbs. and will require more than one person to lift, transport and assemble.

! CAUTION

Be careful during assembly and disassembly of the boom components. Keep pins in place to avoid uncontrolled movement of boom components. Have control of boom components before removing any pins.

Procedure:

1. Lock the two swivel casters on the carriage. Using the boom height adjustment handle, position the puller mount with the receiver tube parallel to the ground. Insert the supplied 3' or 4' boom tube into the receiver tube. (See Photo 13a). Pull the spring-loaded boom pin located on the receiver tube and fully insert boom tube until it completely fills the sight hole in the back of the receiver tube. (See Photo 13b & 13c). Rotate the boom tube until one of the pre-drilled holes in the boom tube locks into place with the spring-loaded boom pin. Ensure the spring-loaded boom pin is fully engaged in the boom tube hole before proceeding to the next step.

NOTE: When using pipe other than the boom tubes supplied by Current Tools, fully insert the pipe or conduit and install a 1/2-13 x 2" bolt (user provided) into the threaded nut on the side of the receiver tube and tighten against the boom tube. (See photo 13C).

13a



13b

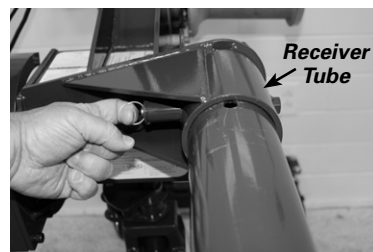

13c

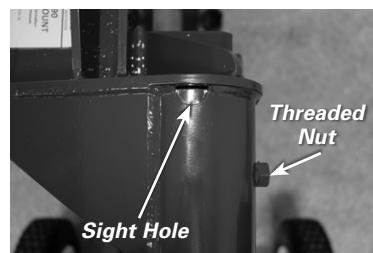

ASSEMBLY INSTRUCTIONS — CONTINUED

2. If only one boom tube is needed, slide the Model #1840 nose unit onto the boom tube you installed in Step #1. (See Photo 14a). Determine the type of pull to be made (up pull, down pull, side pull) and turn the nose unit accordingly. Pull the spring-loaded boom pin located on the nose unit and fully insert the nose unit until it completely fills the sight hole. (See Photo 14b). Rotate the nose unit until the spring-loaded boom pin locks it into the proper position for the pull. Ensure the spring-loaded retainer pin is fully engaged in the boom tube before proceeding to the next step.

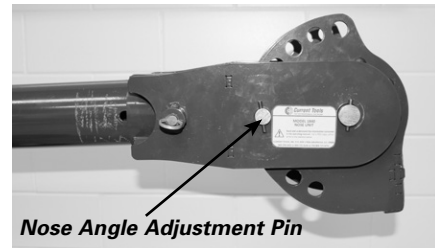

14a

3. Choose the correct size coupling for the size conduit that you will be pulling in and install it into the coupling adapter on the nose unit. (See coupling selection on pg. 10).

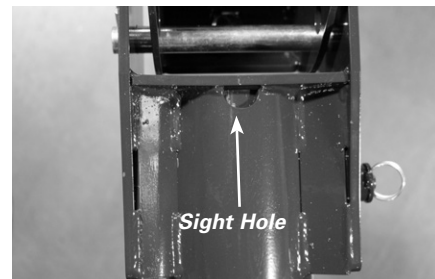

14b

4. To insert the coupling into the conduit, unlock the two swivel casters on the carriage and position the cable puller near the pull sight. Using the boom height adjustment handle, raise or lower the boom until the slip-in coupling fully seats in the conduit. The coupling is fully seated when the coupling ring makes contact with the conduit you are pulling in. (See Photo 14c). It may be necessary to adjust the angle of the coupling so that it seats properly in the conduit. To do this, remove the spring clip from the angle adjustment pin on the nose unit, remove pin, and adjust the angle of the coupling. When the correct angle is achieved, re-insert the pin and secure with the spring clip.

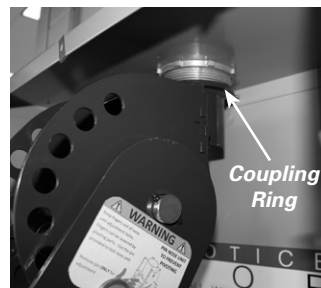

14c

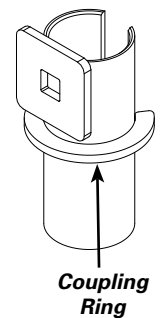

5. The Puller Mount offers a patent pending feature known as the **ROTABOOM™** that gives the Puller Mount the ability to swivel approximately 45 degrees in two directions. This allows the puller to be used in tighter spaces. To use the **ROTABOOM™**, pull down on the spring loaded retainer pin located under the puller mount and swivel the puller as needed (see photo 14d). Once the pull is completed and you are ready to transport the puller, return the puller mount to the center position and ensure the spring loaded retainer pin snaps into place.

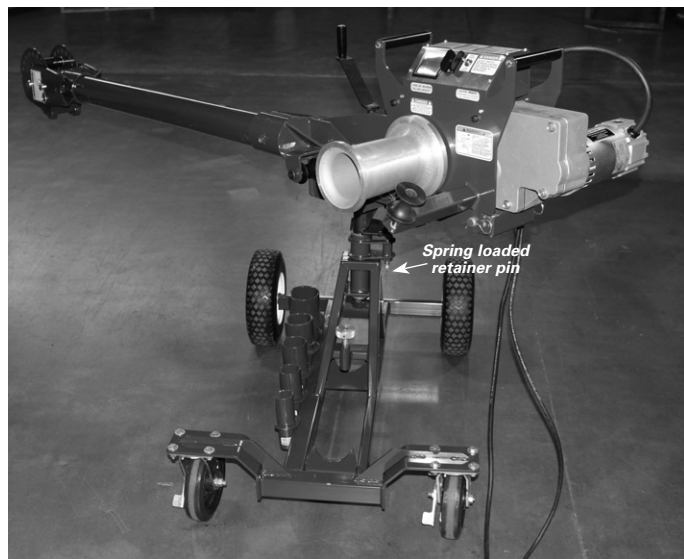

14d

ASSEMBLY INSTRUCTIONS — CONTINUED

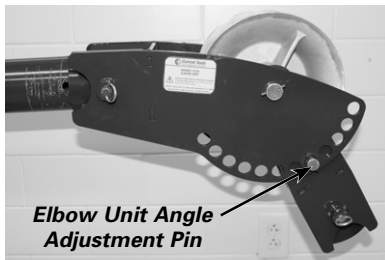

15a



15b

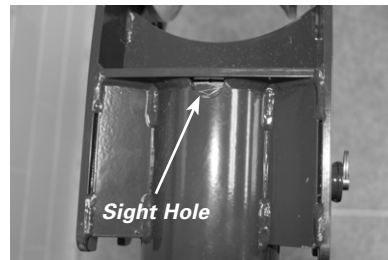

15c

If more reach is needed, an extra boom tube is provided. To install, continue assembly instructions as follows:

NOTE: The extra boom tube can be stored on the lower half of the carriage frame and secured with the provided locking screw.

6. Remove the nose unit from the boom tube you installed in Step #1. Slide the Model #1710 elbow unit onto the end of the boom tube as shown in Photo 15a. Pull the spring-loaded boom pin on the elbow unit and fully insert the elbow unit until it completely fills the sight hole. (See Photos 15b & 15c). Rotate the elbow unit until the spring-loaded boom pin locks it into the proper position for the pull.



15d

7. Slide the additional boom tube into the elbow unit. Pull the spring-loaded boom pin on the elbow unit and fully insert the additional boom tube until it completely fills the sight hole. Rotate the boom tube until the spring-loaded retainer pin locks it into position. (See Photo 15d).



15e

8. Refer to step #2 in the Assembly Instructions section and install the Model #1840 nose unit on the end of the additional boom tube. (See Photo 15e).
9. If angle adjustment is needed, remove the spring clip from the elbow unit angle adjustment pin, remove the pin and adjust the angle to the desired degree. When the correct angle is achieved, re-insert the pin and secure with the spring clip.
10. You are now ready to pull cable.
11. If more reach is required, both the 3' and 4' lengths of factory supplied boom tubes may be replaced with up to 10' lengths of 3" rigid conduit or 3" schedule 40 pipe. **ONLY** use 3" rigid conduit or 3" schedule 40 pipe for boom tubes. **NEVER** substitute any other size or type of conduit or pipe for boom tubes. **NEVER** replace factory supplied boom tubes with shorter boom tubes.

NOTE: The weight of boom sections longer than the factory supplied booms will require manual assistance to use the boom height adjustment handle.

IN ADDITION, screw-on couplings may be necessary to support the boom and prevent it from falling.

⚠ WARNING

When using one boom tube and nose unit, factory supplied boom tube may be replaced but must meet the following specifications:

- Only use 3" schedule 40 pipe or 3" rigid conduit
- Check sight holes to be sure boom tubes are fully inserted. Then tighten 1/2-13 x 2" hex bolt (user provided).

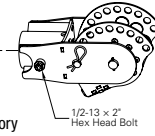

- DO NOT transport the puller on the carriage with boom tubes other than the factory supplied 3' and 4' tubes.

When using elbow unit, nose unit and both boom tubes, factory supplied boom tubes may be replaced but must meet the following specifications:

- Only use 3" schedule 40 pipe or 3" rigid conduit
- Check sight holes to be sure boom tubes are fully inserted. Then tighten 1/2-13 x 2" hex bolt (user provided).

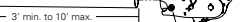
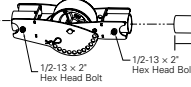
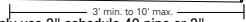

- DO NOT transport the puller on the carriage with boom tubes other than the factory supplied 3' and 4' tubes.

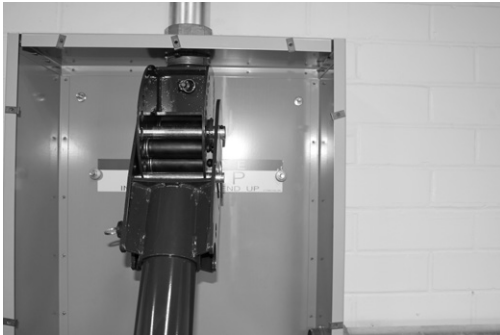

Down Pull



Side Pull



Up Pull



Up Pull using 45° horizontal pivot feature and one boom tube

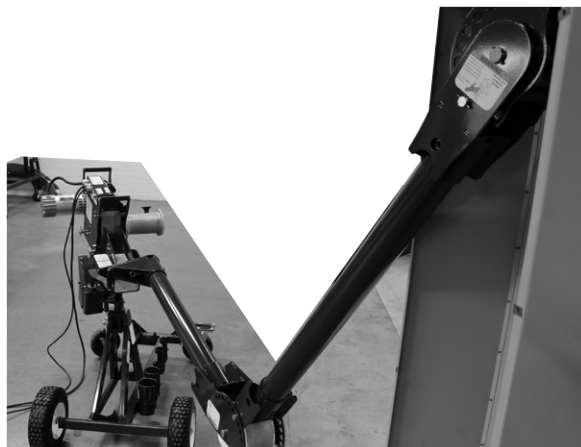

Down Pull using elbow unit and nose unit with 45° horizontal pivot feature

TRANSPORT INFORMATION

The Mobile Carriage is designed to easily move the Pulling Assembly from location to location.

To Prepare for Transport

Before moving, use the boom height adjustment handle and raise the boom tube as shown in Figure 17. If both sections of the standard boom tubes are installed, remove the elbow unit angle adjustment pin and rotate the forward section down as far as possible (See Figure 17). Reinstall the elbow unit angle adjustment pin. DO NOT transport with boom tubes longer than the factory supplied 3' and 4' sections.

NOTE: ALWAYS return the puller mount to the center position and ensure the spring loaded retainer pin snaps into place prior to transport.

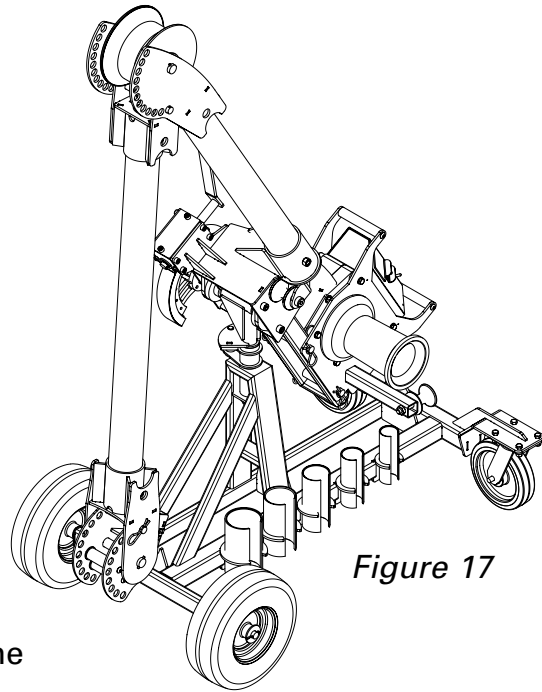
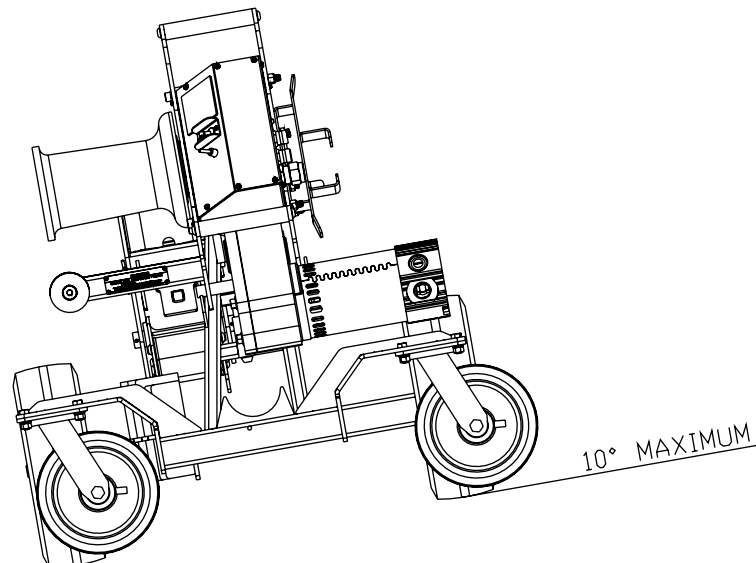

Figure 17

WARNING

- Tip Hazard — DO NOT lean unit more than 10°.
- DO NOT transport with boom tubes longer than the factory supplied 3' and 4' sections.
- Only transport on firm, smooth surfaces.
- Keep unit under control when transporting.



FLOOR/CHAIN MOUNT

The Model #2280 floor mount and #2281 chain mount are made to fit the Current Tools Model #1450 Cable Puller and can be mounted using two different procedures as noted on pages 18 through 22.

PROCEDURE #1 ***Mounting to a concrete floor*** ***(Model #2280 floor mount)***

Safety Information

1. ALWAYS mount to a smooth, flat concrete floor with a minimum 3000 psi rating.
2. Mount only to a concrete floor. **NEVER** mount to cinder blocks, brick, etc.
3. Wedge anchors must be at least 12" away from edge of concrete.
4. ALWAYS use new anchors. **NEVER REUSE ANCHORS.**
5. Use only 5/8" x 6" wedge anchors or equivalent with a tension and shear rating of 2,500 lbs. (Current Tools part #8045-3)
6. **⚠ CAUTION** ALWAYS wear eye protection when installing anchors.

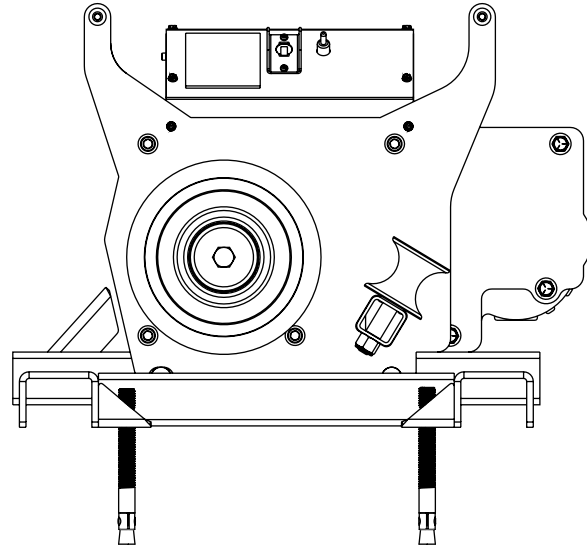

⚠ WARNING

ALWAYS place the Model #2280 floor mount close to the conduit. This will reduce the possibility of injury should the rope break. See Figure 18a.

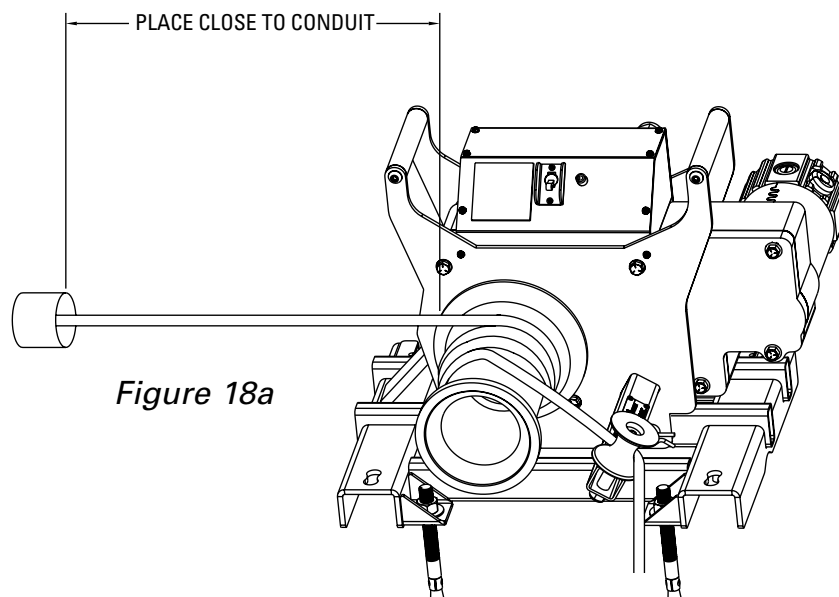
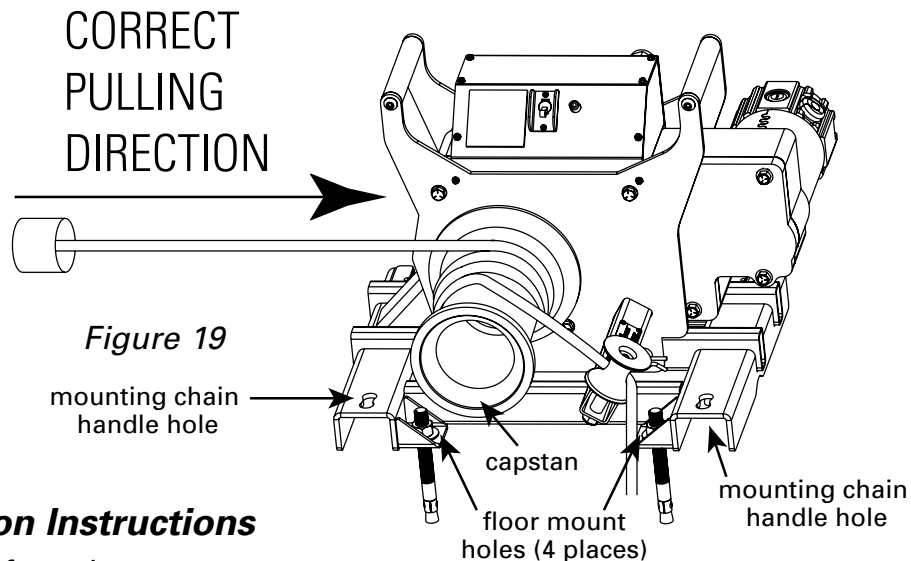

Figure 18a

! CAUTION

The pulling direction should **ALWAYS** be parallel to the base of the floor mount. See Figure 19.



Installation Instructions

1. Wear safety glasses.
2. Follow the safety instructions provided by the drill manufacturer.
3. Use only 5/8" diameter solid carbide tipped bits that meet ANSI B94-12.
4. Using the floor mount as a template, drill four 5/8" holes a minimum of 6" deep but not closer than 1 1/4" to the bottom (opposite surface) of the concrete. Be sure to drill the holes perpendicular to the work surface and do not ream the holes or let the drill bit wobble.
5. Clean the holes with compressed air and a wire brush. Clean holes are necessary for proper performance.
6. Assemble the washer and nut on the anchor so the top of the nut is flush with the top of the anchor.
7. Next, drive the 4 wedge anchors through the 4 floor mount holes (See Figure 19 and 20a) and into the concrete holes, making sure the nut and washer rests solidly against the floor mount.

8. Tighten the anchors with a torque wrench to 75-90 ft. lbs.

NOTE: If anchor spins, pull up on the anchor using the claw end of hammer and then torque. If spinning still occurs, DO NOT use this location; reposition the floor mount and repeat this installation procedure.

9. Install model #1450 puller onto the floor mount by lowering the puller over the floor mount and inserting the puller mount pins (see Figure 20b). Secure the puller mount pins with spring clips. NOTE: The puller **MUST** be mounted onto the floor mount with the capstan on the same side as the mounting chain handle holes (see Figure 19).

Floor Mount Anchor Holes

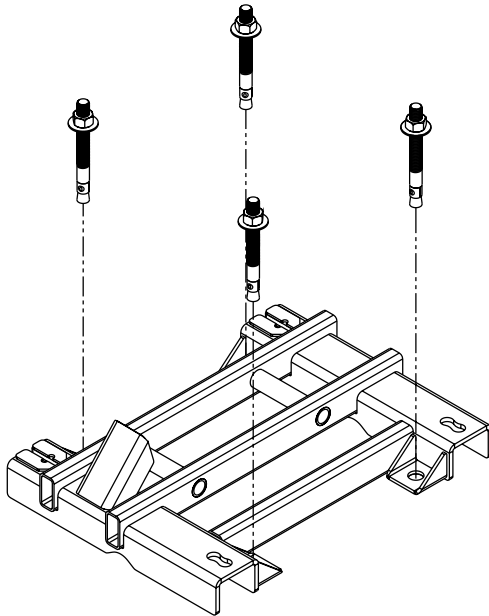

Figure 20a

Installing Puller on Floor Mount

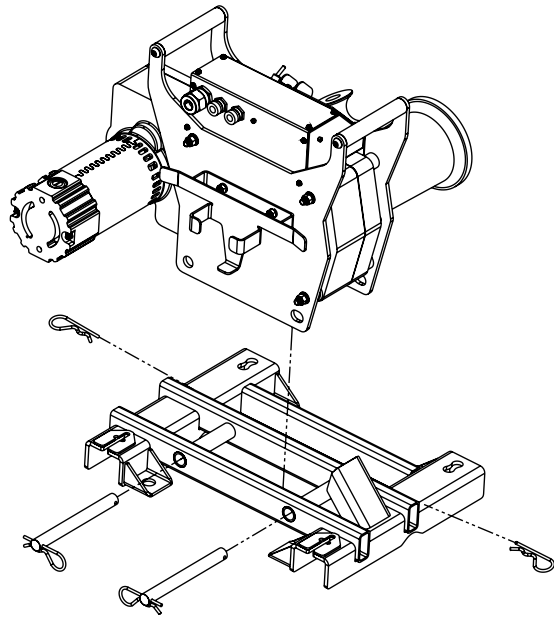

Figure 20b

Tandem Pulling

If the amount of pulling force required to make a pull exceeds the load rating for a single cable puller, two cable pullers may be used in tandem to make the pull. (See Figure 20c below). Be sure to use a separate rope and set of accessories for each cable puller. Each set of rope and accessories should meet or exceed each cable pullers maximum pulling force.

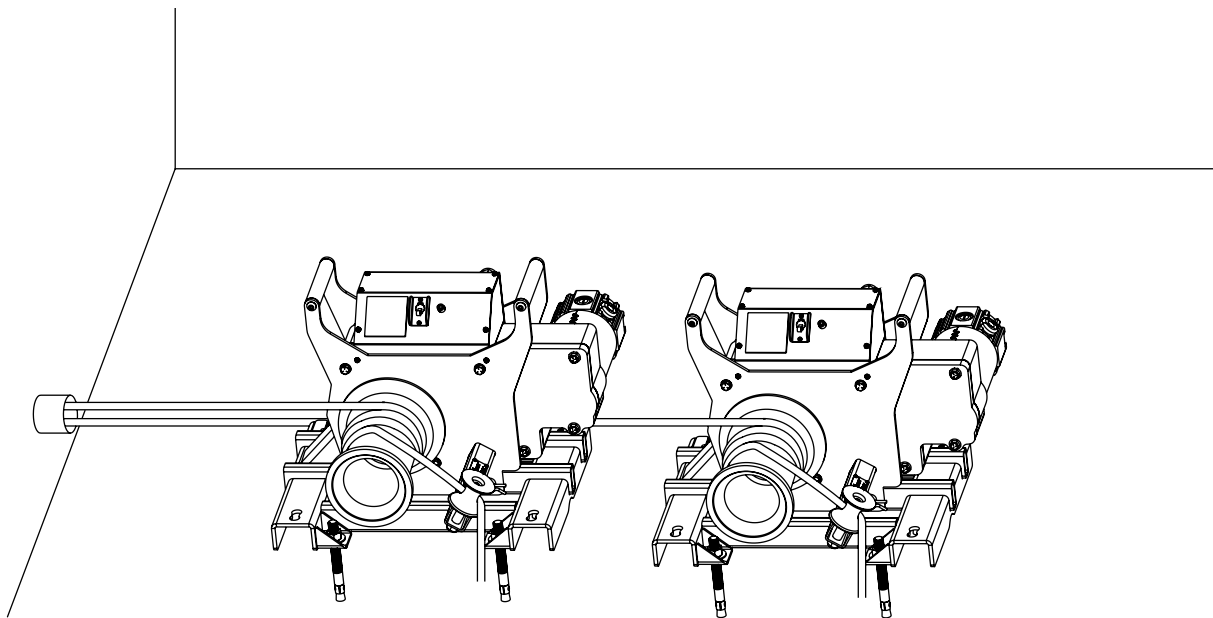

Figure 20c

FLOOR/CHAIN MOUNT — CONTINUED

PROCEDURE #2

Mounting Chain Instructions (Model #2281 chain mount)

The Model #2281 chain mount is designed to be secured to conduit or structural supports using the two chains provided. The handles on the chains should provide sufficient leverage to tighten the chains securely. No other tools are needed. Be sure to check the mounting chains for kinks and twists before you tighten them. See Warning below for proper mounting chain installation.

! WARNING

When using the Model #2281 chain mount, never tighten chain as shown in Figure A. This causes side loading of the chain and can result in failure of the chain or screw causing components to come loose and possibly cause serious injury or death. Figure B shows the proper alignment of screw and chain for tightening.

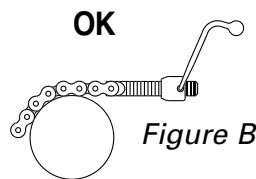
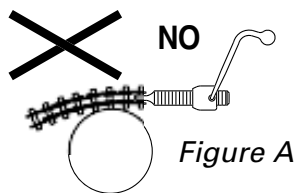

- A** Loosen the mounting chain handle so that only 3 or 4 threads remain engaged.
- B** Wrap the chain around the floor mount, conduit or structural support sufficient to handle the pulling forces.
- C** Pull the loose end of the mounting chain tight and hook the closest chain link into the recessed area.
- D** Tighten the chain handle. Repeat this process for second mounting chain.

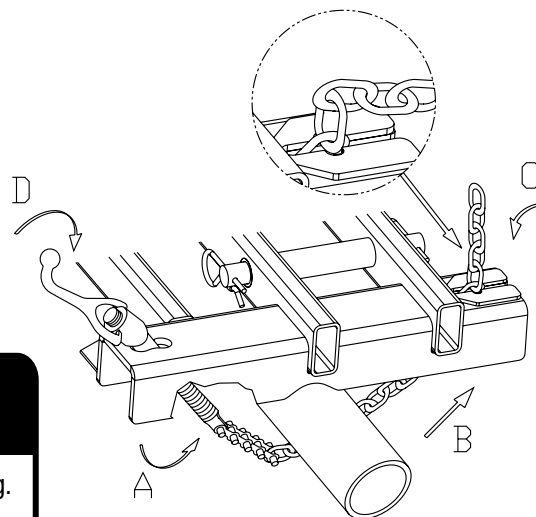

! DANGER

ALWAYS ensure cable puller is properly secured before operating.
ALWAYS attach to supports that are at least 2" and not more than 10" wide.

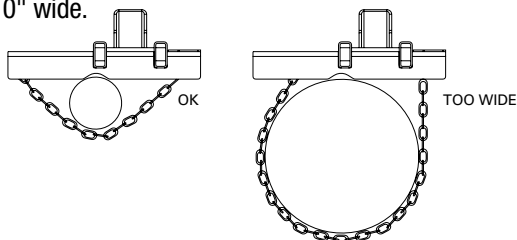

! WARNING

Be sure threads do not bottom out before chain becomes tight.

FLOOR/CHAIN MOUNT — CONTINUED

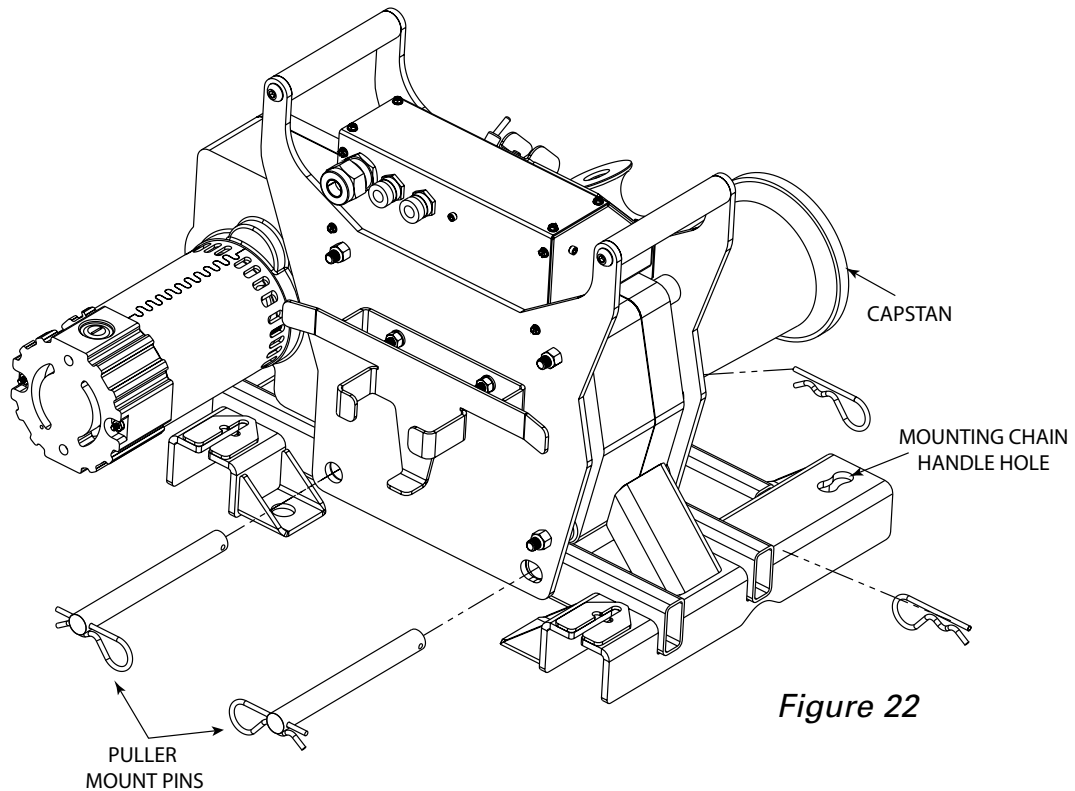

Figure 22

NOTE: Install Model #1450 puller onto the chain mount by lowering the puller over the chain mount and inserting the puller mount pins (See Figure 22). Secure the puller mount pins with spring clips. The puller **MUST** be mounted onto the chain mount with the capstan on the same side as the mounting chain handle holes. (See Figure 19).

⚠ WARNING

1. The only approved method to secure the Model #2281 chain mount is with the 2 mounting chains provided. **DO NOT** attempt to use any other object to secure the puller.
2. Inspect the mounting chains for wear before each installation.
3. **NEVER** alter the mounting chains or handles.

⚠ WARNING

ALWAYS inspect the structural integrity of any supports, conduit, anchoring system etc. that will hold the cable puller during the pull. These supports should be able to withstand the maximum pulling force of the cable puller plus a safety factor of 3:1. Example: 10,000 lb. puller should be anchored to a support that can withstand 30,000 lbs. of pull.

⚠ WARNING

DO NOT mount the Model #2281 chain mount to square columns or I-Beams. The mounting chains will not tighten properly on these structures.

⚠ WARNING

When using the Model #2281 chain mount, never tighten chain as shown in Figure A. This causes side loading of the chain and can result in failure of the chain or screw causing components to come loose and possibly cause serious injury or death. Figure B shows the proper alignment of screw and chain for tightening.

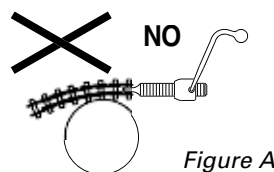

Figure A

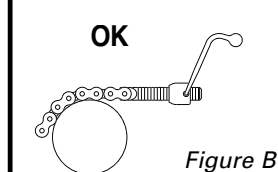
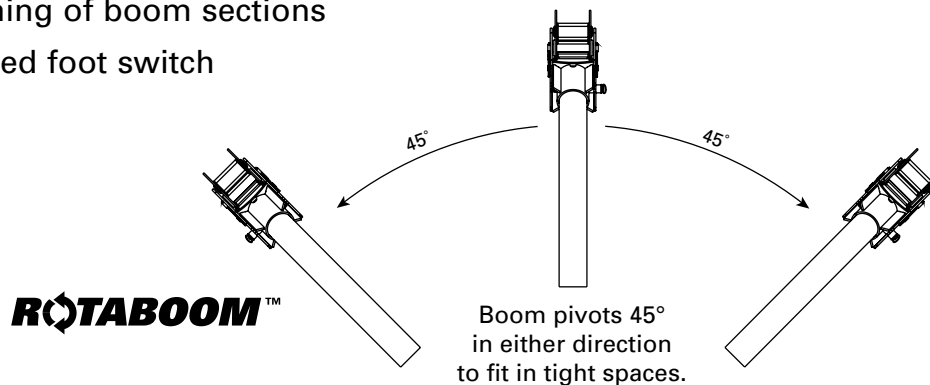

Figure B

FEATURES

- One person set up
- 45 degree horizontal pivot **ROTABOOM™** allows for use of puller in tight spaces (patent pending). See drawing below.
- Built-in force gauge with digital read out and color screen to indicate force ranges
- Circuit breaker on/off switch — helps protect motor
- Two speeds
- Safety pawl on capstan sprocket to prevent reverse rotation
- Tapered capstan to help avoid rope overlap
- Tailing rope safety roller for operator safety — lets operator stand out of the direct line of tight pulling rope
- Two handles for carrying or positioning puller
- Simple electrical system for easy maintenance
- Boom height adjustment handle allows for easy vertical positioning of boom sections
- Integrated foot switch



SPECIFICATIONS — MODEL 1450 CABLE PULLER

Model no.	1450 Cable Puller
width	24"
length	19 1/4"
height	15"
weight	119 lbs.

maximum pulling force — 10,000 lbs.

	<u>Low Speed</u>	<u>High Speed</u>
speeds (approx.)	no load — 12 FPM	no load — 48 FPM
	2,000 lbs. — 11 FPM	1,000 lbs. — 36 FPM
	4,000 lbs. — 10 FPM	1,500 lbs. — 29 FPM
	6,500 lbs. — 8 FPM	2,000 lbs. — 24 FPM

motor — 120 volts AC, 60 hertz, 20 amps

FEATURES — MODEL 1450 CABLE PULLER

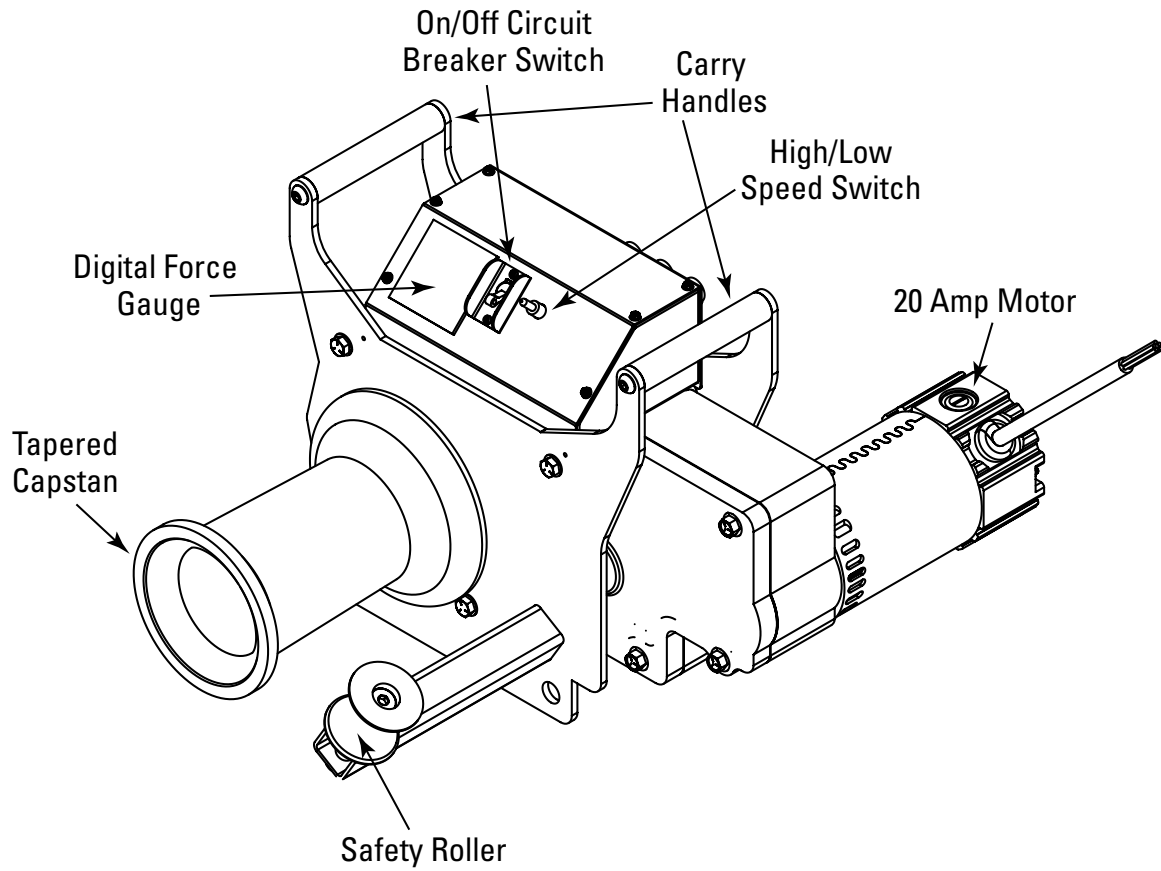



CABLE PULLING BASICS

Model 1450 Cable Puller and Accessories

The Model 1450 Cable Puller has a maximum pulling force of 10,000 lbs. Therefore, all of the accessories used to make a cable pull with this unit must be rated to meet or exceed the forces generated. This includes, but is not limited to pulling rope, sheaves, swivels, grips, etc. Be aware that the pulling force on a sheave and its anchoring system can be as great as twice the pulling force generated by the cable puller.

Force Gauge

The Model 1450 Cable Puller is equipped with an built-in force gauge. The operator should always monitor the force gauge throughout the entire cable pull. The force gauge has 3 color screens to help you identify operating conditions. These screens are:

COLOR	PULLER FORCE	CONDITION
Green	0-6,500 lbs.	Puller can be run continually
White	6,500 lbs. -8,000 lbs.	50% duty cycle; 5 minutes on / 5 minutes off
Flashing Red	8,500 lbs. -10,000 lbs.	Overload condition — momentary operation of puller only. Correct the overload condition.

WARNING

DO NOT exceed load rating of cable puller, rope or accessories.

CAUTION

Inspect all components of the pulling system before beginning any cable pull. This includes the pulling system (cable puller, boom, etc.) and any accessories (sheaves, swivels, pins, etc.) Replace any worn or defective components.

Power Requirements

The Model 1450 Cable Puller motor is rated at 120 volt – 60 hz – 20 amps.

WARNING

ALWAYS plug the Model 1450 Cable Puller into a grounded receptacle with a 20 amp GFCI protected circuit. DO NOT modify the plug provided with the Model 1450 Cable Puller. If needed, have a 20 amp GFCI receptacle installed by a qualified electrician.

CAUTION

If an extension cord is used, it should be a minimum of 12 gauge wire with ground and a maximum length of 100 ft.



CABLE PULLING BASICS — CONTINUED

Model 1450 Cable Puller — mounting to Model 1190 Puller Mount.

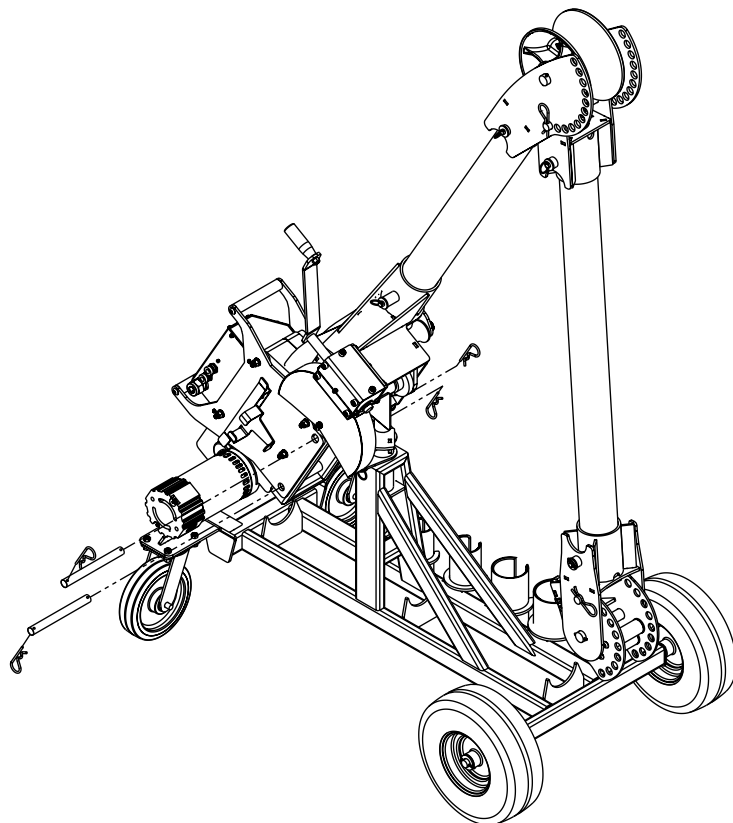
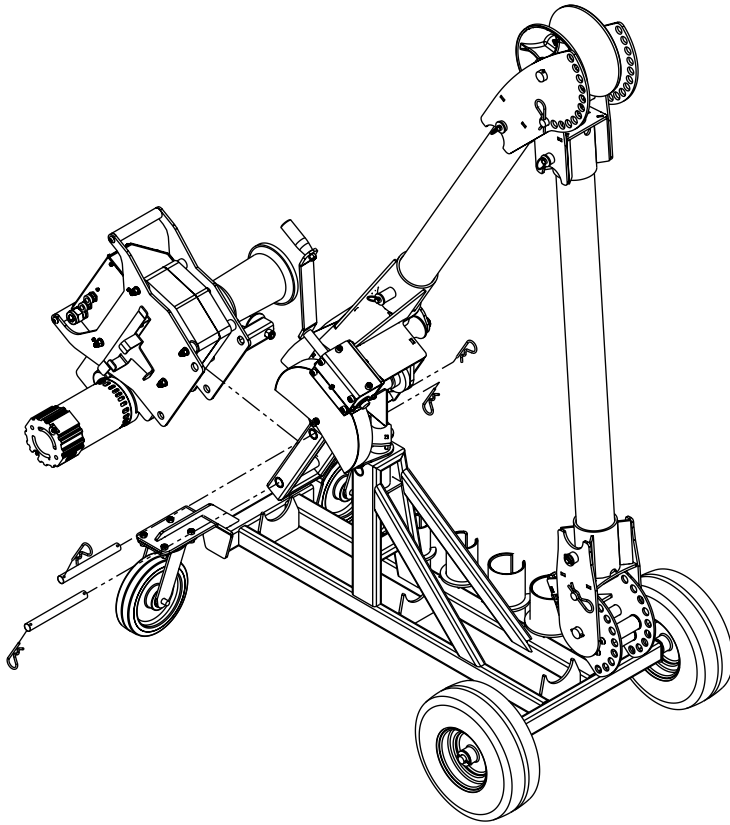



OPERATING INSTRUCTIONS — MODEL 1450 CABLE PULLER

! DANGER

DO NOT operate cable puller in wet or damp locations. Do NOT expose to rain.

! DANGER

DO NOT operate in an explosive atmosphere.

! DANGER

DO NOT use cable puller as a hoist or for lifting, supporting or transporting people or loads. Use only for its intended purpose as a cable puller.

Rope Set-Up

As shown in the overhead view, Figure 27a, the pulling rope must approach the capstan at a 90° angle. This will help avoid rope overlap.

Make several wraps of the pulling rope around the capstan, beginning at the housing end of the capstan. See Figure 27a.

Next, guide the pulling rope around the black safety roller as shown in Figure 27a. This will enable the operator to stand at a 90° angle to the cable puller and out of the direct line of tight pulling rope.

Also note the pulling rope should approach the capstan as indicated in Figure 27b.

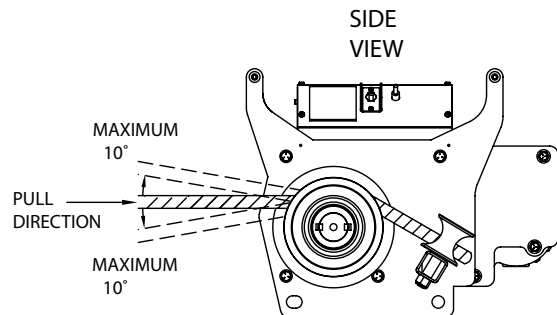
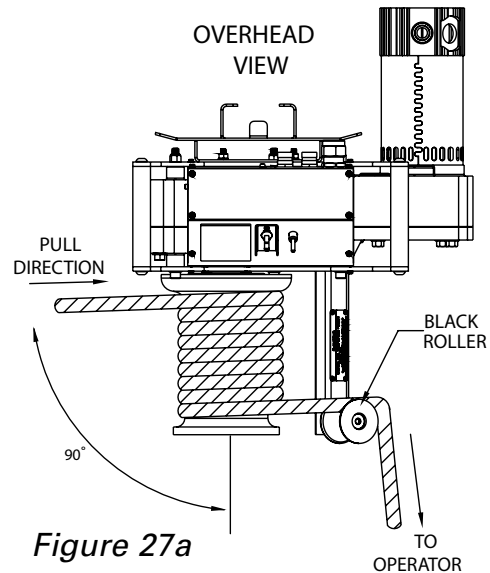



OPERATING INSTRUCTIONS — CONTINUED

WARNING

Rope should approach capstan as shown in Figure 27b.

ALWAYS use black roller to guide rope so that operator stands at 90° angle to the cable puller and out of the direct line of tight pulling rope. See Figure 27a.

ALWAYS wrap rope beginning at housing end of capstan as shown in Figure 27a.

To help avoid rope overlap, rope must approach capstan at a 90° angle. See Figure 27a.

WARNING

Rope Requirements: Use only 7/8" or larger double-braided composite pulling rope with a minimum average breaking strength of 32,000 lb.

Be sure to inspect rope for damage before each cable pull.

CAUTION

Wear eye protection when operating cable puller.

Pulling Operation

1. Be sure the cable puller circuit breaker switch is in the off position.
2. Select High or Low speed as indicated on the puller.
3. Operator should be able to see and monitor the force gauge throughout the entire cable pull.
4. Hold the tailing end of the pulling rope as it comes off the black safety roller (see Figure 27a) and pull slightly. Turn the cable puller circuit breaker ON.

Note: The tailing rope is that portion of the pulling rope that has passed the capstan and is now excess to the pull. By pulling on the tailing rope the operator can control and vary the pulling force. It should require no more than 10 lbs. of tailing force by the operator to engage the pulling rope on the capstan. If the rope slips on the capstan, turn the puller off and add an additional wrap of rope around the capstan. Also note that with the tailing force at a constant pull, each additional wrap of rope around the capstan will approximately double the pulling force of the cable puller.



OPERATING INSTRUCTIONS — CONTINUED

5. Depress the foot switch to activate the puller. As the rope is tailed, it should mound on the floor between the operator and the cable puller.
6. Release pressure off of the foot switch to stop the puller. Turn the cable puller circuit breaker switch to the **OFF** position when the pull is completed.

NOTE: If for any reason you need to stop during a pull, release pressure on the foot switch, turn the cable puller **OFF** and tie off the tailing rope to hold it in place.

Note: The Model 1450 Cable Puller is equipped with a circuit breaker switch. If the amperage rating of the breaker is exceeded the puller will stop. Before restarting the pull, allow the motor to cool and determine the cause for the overload condition. Correct before restarting the pull.

WARNING

NEVER allow the rope to slip on a rotating capstan for more than a couple of seconds. The rope will wear in that spot and the rope could break under pressure. If you need to stop the pull, turn the cable puller off and tie the rope off to hold it in place until you restart your pull.

WARNING

This cable puller is equipped with an anti-reversing pawl. The pawl will make a clicking sound when the capstan is rotating. If you can not hear the clicking sound as the capstan rotates, immediately turn the cable puller off and do not use until repaired.

WARNING

Keep all body parts, hair, loose clothing, etc. away from rotating parts and pinch points. Keep hands away from capstan.

DO NOT wrap rope around any body parts. DO NOT wrap rope around wrists.

ALWAYS keep the tailing rope away from the operator's feet.



OPERATING INSTRUCTIONS — CONTINUED

WARNING

Rope must ALWAYS be pulled over a **rotating** sheave. If a sheave does not rotate, turn cable puller off immediately and determine the problem before continuing the pull.

WARNING

Pulling Rope should be the only thing to contact the capstan. NEVER let swivels, grips, etc. come in contact with the capstan.

WARNING

NEVER allow the rope to overlap on the capstan. If this condition begins to occur, immediately release the tailing force on the rope so that the rope can feed back toward the conduit or cable tray. If this does not remedy the overlap, turn off the cable puller immediately. **There is no known solution for rope overlap.**

WARNING

Keep as much rope confined in the conduit as possible. This will help prevent injury should the rope break and whip violently.

WARNING

When making a vertical cable pull, keep the area underneath the cable pull clear of all personnel.

 **WARNING**

Unplug the cable puller before servicing.

 **CAUTION**

DO NOT alter this cable puller. Doing so will void the warranty. Guards and safety features are provided for your protection.

Capstan

Replace the capstan if it is grooved more than 1/16" deep.

Lubrication

Wheels and casters — Grease as needed with a good quality multi-purpose grease. Grease fittings are located on the wheel and caster.

Worm Box Assembly — Grease as needed with a good quality multi-purpose grease. Start with puller mount in fully upright (transport) position and insert one pump of grease. Rotate worm box handle one full turn and insert another pump of grease. Continue this sequence until puller mount is fully in the down position. Grease fitting is located on the side of the worm box assembly.

Inspection

Motor Brushes – Inspect the two motor brushes every 30 hours. Replace if less than 3/8" long. Always replace both brushes at the same time.

EXPLODED VIEW – MODEL 1450 CABLE PULLER

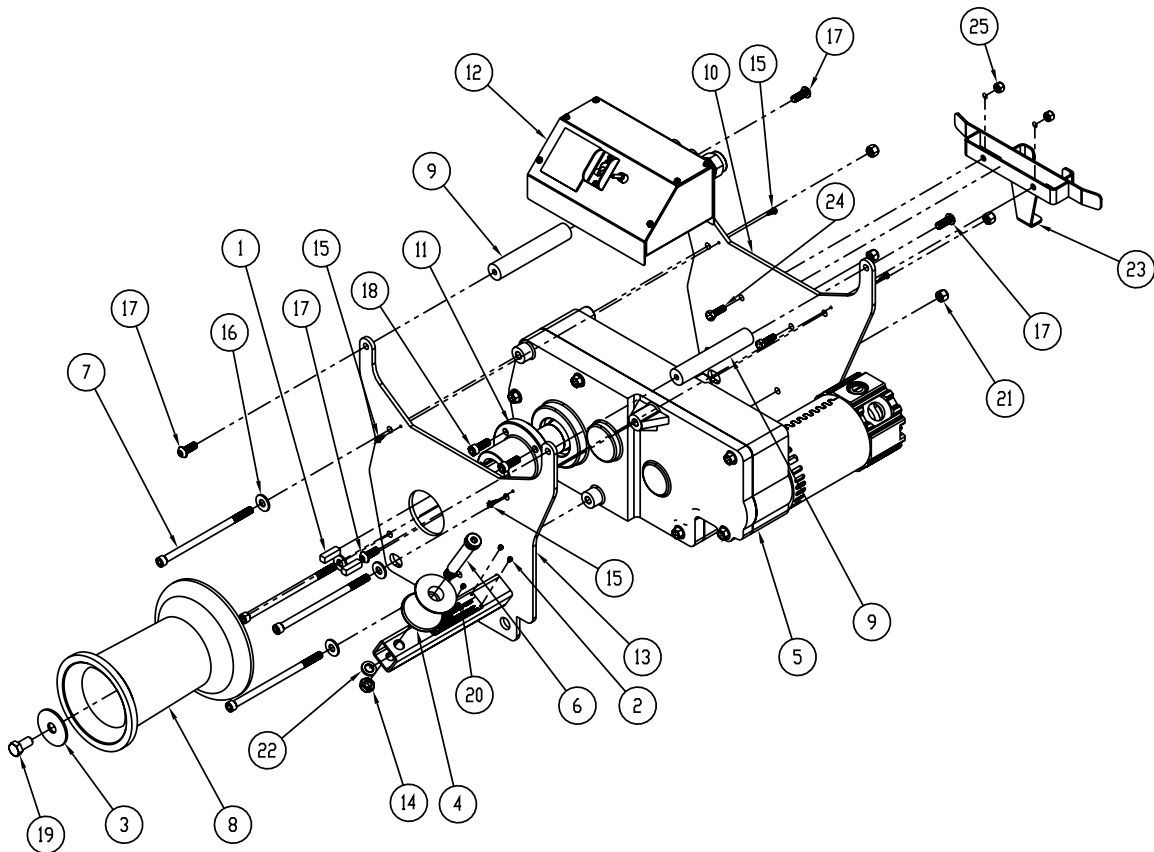

PARTS LIST – MODEL 1450 CABLE PULLER

ITEM #	PART #	DESCRIPTION	QTY.
1	66-38	KEY-SQUARE (3/8" × 1.25" LG)	2
2	77-044	RIVET, ALUM, BUTTONHEAD (1/8" .08-.120 GRIP)	4
3	88-59	WASHER - 11 GA HRPO ZINC (.630ID × 2.25OD)	1
4	88-18	ROLLER – GUIDE, PULLER	
5	100-001	MOTOR	1
6	100-022	SCREW – SHOULDER SOCKET (5/8-11 3)	1
7	100-023	SCREW - SOCKET HEAD CAP (3/8-16 × 7")	4
8	100-142	CAPSTAN	1
9	100-146	PULLER HANDLE	2
10	100-148	PULLER PLATE 2	1
11	100-149	CAPSTAN HUB	1
12	100-191	ELECTRONICS BOX ASSEMBLY (See exploded view on pg. 33)	1
13	100-216	PULLER PLATE	1
14	281-1J	NUT – HEX NYLON INSERT (1/2-13) – THIN	1
15	452-6A	SCREW-SELF DRILL (#8 1/2)	10
16	506-3	WASHER – FLAT 3/8 (USS) ZINC	8
17	610-21	SCREW – BUTTON HEAD CAP (3/8-16 × 1)	4
18	750-25	SCREW – SOCKET HEAD CAP (3/8-16 × 1)	4
19	8092-2	SCREW – HEX HEAD CAP GR5 ZINC (1/2-13 × 1)	1
20	1450-S/N PLATE	SERIAL NUMBER PLATE	1
21	2-1501-4	NUT-HEX, NYLON INSERT 3/8-16	4
22	281-2C	WASHER – LOCK, 1/2"	1
23	33-706	WELDMENT – WIRE/FOOT SWITCH HOLDER	1
24	77-00D1	SCREW – HEX HEAD CAP GR5 ZINC (5/16-18 × 3/4)	2
25	2-1301-4	NUT – HEX NYLON INSERT (5/16-18)	2

EXPLODED VIEW – MODEL 1450 ELECTRONICS BOX ASSEMBLY

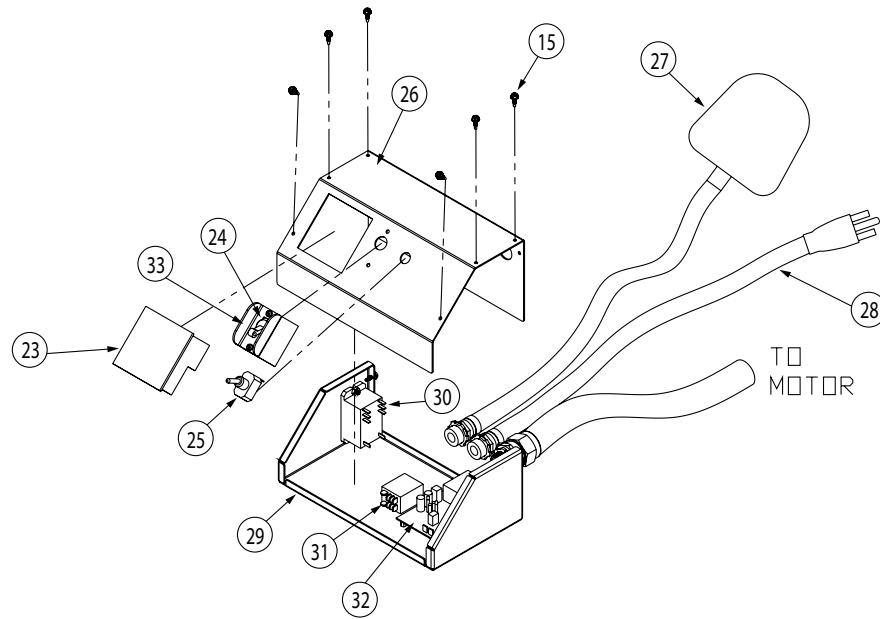

PARTS LIST – MODEL 1450 ELECTRONICS BOX ASSEMBLY

ITEM #	PART #	DESCRIPTION	QTY.
23	100-003	FORCE GAUGE	1
24	77-062	CIRCUIT BREAKER	1
25	77-051	TOGGLE SWITCH	1
26	100-189	COVER – ELECTRIC BOX	1
27	99-122	FOOT SWITCH	1
28	77-068	POWER CORD	1
29	100-190	FRAME – ELECTRIC BOX	1
30	100-004	RELAY	1
31	100-008	RELAY	1
32	100-002	CIRCUIT BOARD	1
33	77-063	GUARD – SWITCH	1

EXPLODED VIEW – MODEL 1450 CABLE PULLER GEAR MOTOR

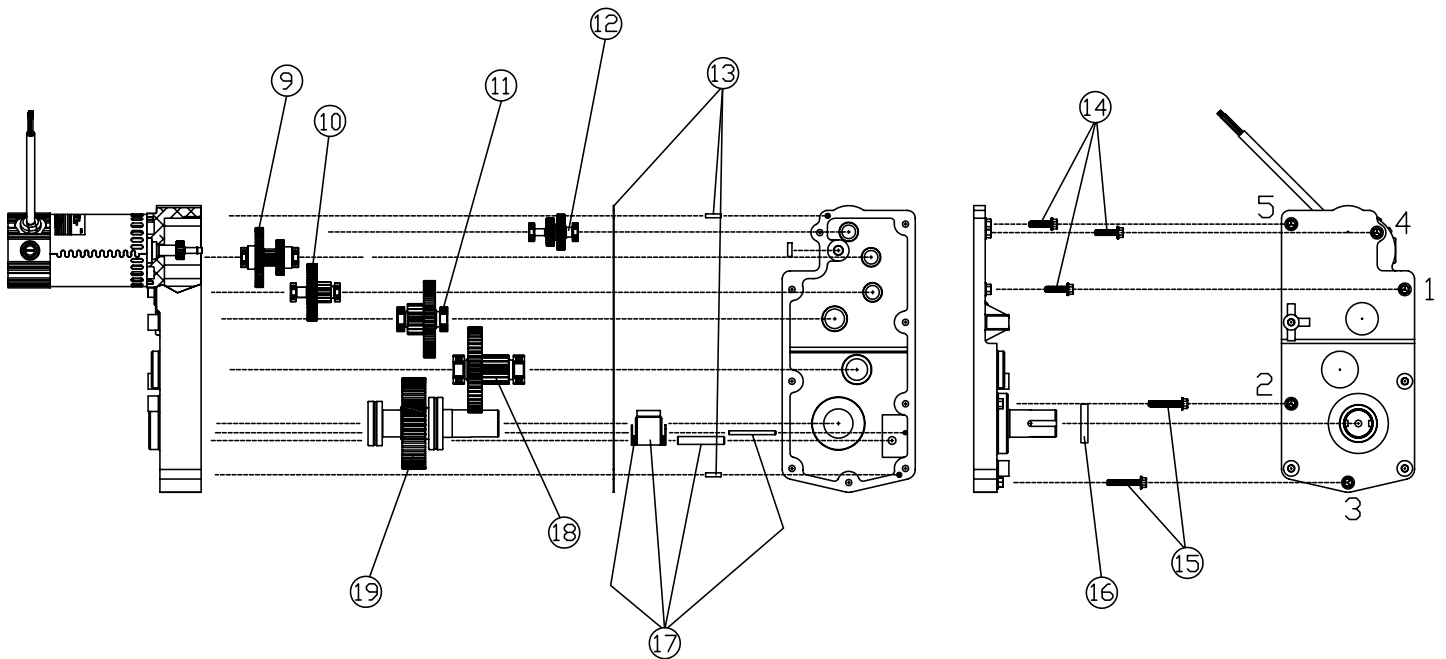
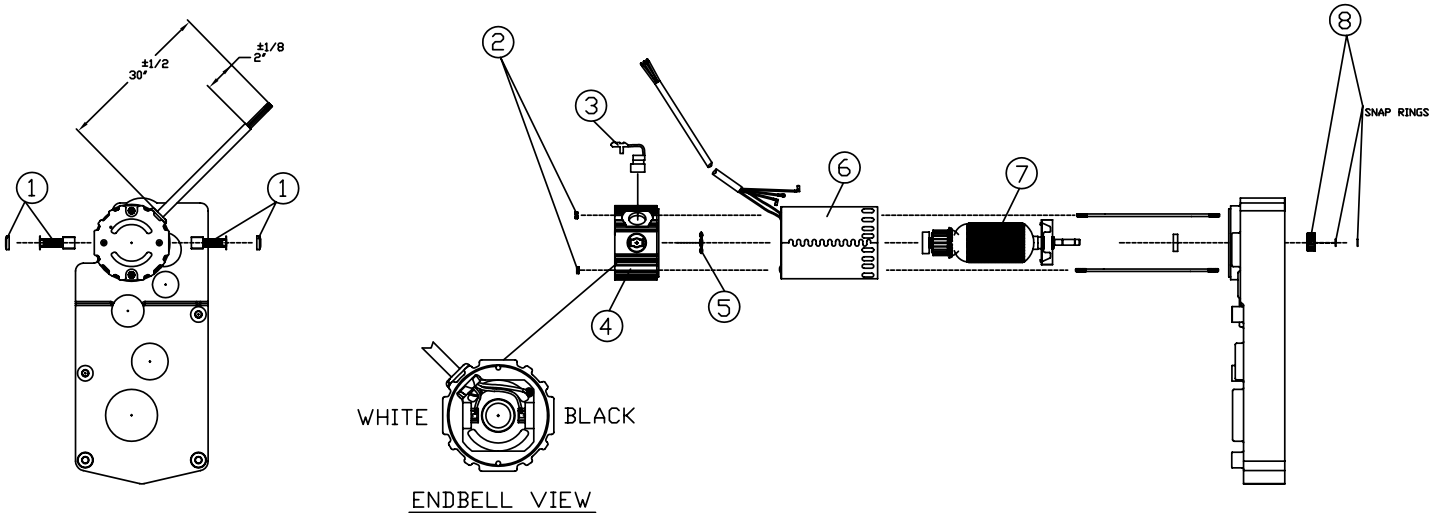



PARTS LIST – MODEL 1450 GEAR MOTOR

ITEM #	PART #	DESCRIPTION	QTY.
1	1000-137	BRUSH ASSEMBLY WITH CAPS	2
2	1000-138	K-LOCK NUT	2
3	1000-139	HEYCO STRAIN RELIEF, BLACK, #1287	1
4	1000-140	COMM ENDBELL ASSEMBLY	1
5	1000-141	3 WAVE SPRING (SSB-0138)	1
6	1000-142	115V FIELD AND FRAME ASSEMBLY	1
7	1000-143	115V ARMATURE AND BEARING ASSEMBLY	1
8	1000-144	1ST STAGE GEAR (PINION) MACHINED/SNAP RINGS (2)	1
9	1000-145	2ND STAGE PINION/GEAR/BEARING ASSEMBLY	1
10	1000-146	3RD STAGE PINION/GEAR/BRG ASSEMBLY	1
11	1000-147	4TH STAGE GEAR/PINION/BRG ASSEMBLY	
12	1000-148	HIGH SPEED IDLER/BRG ASSEMBLY	1
13	1000-149	GEARCASE GASKET AND DOWEL PINS (2)	2
14	1000-150	CAP SCREW 3/8-16 × 2-1/4 (3)	3
15	1000-151	CAP SCREW 3/8-16 × 1-1/2 (2)	2
16	1000-152	OIL SEAL	1
17	1000-153	DOWEL PINION/4TH GEAR/BEARING ASSEMBLY	1
18	1000-154	OUTPUT PINION/4TH GEAR/BEARING ASSEMBLY	1
19	1000-155	OUTPUT SHAFT AND BEARING ASSEMBLY	1



WIRING DIAGRAM - MODEL 1450 CABLE PULLER

INTERNAL ELECTRONICS BOX ASSEMBLY

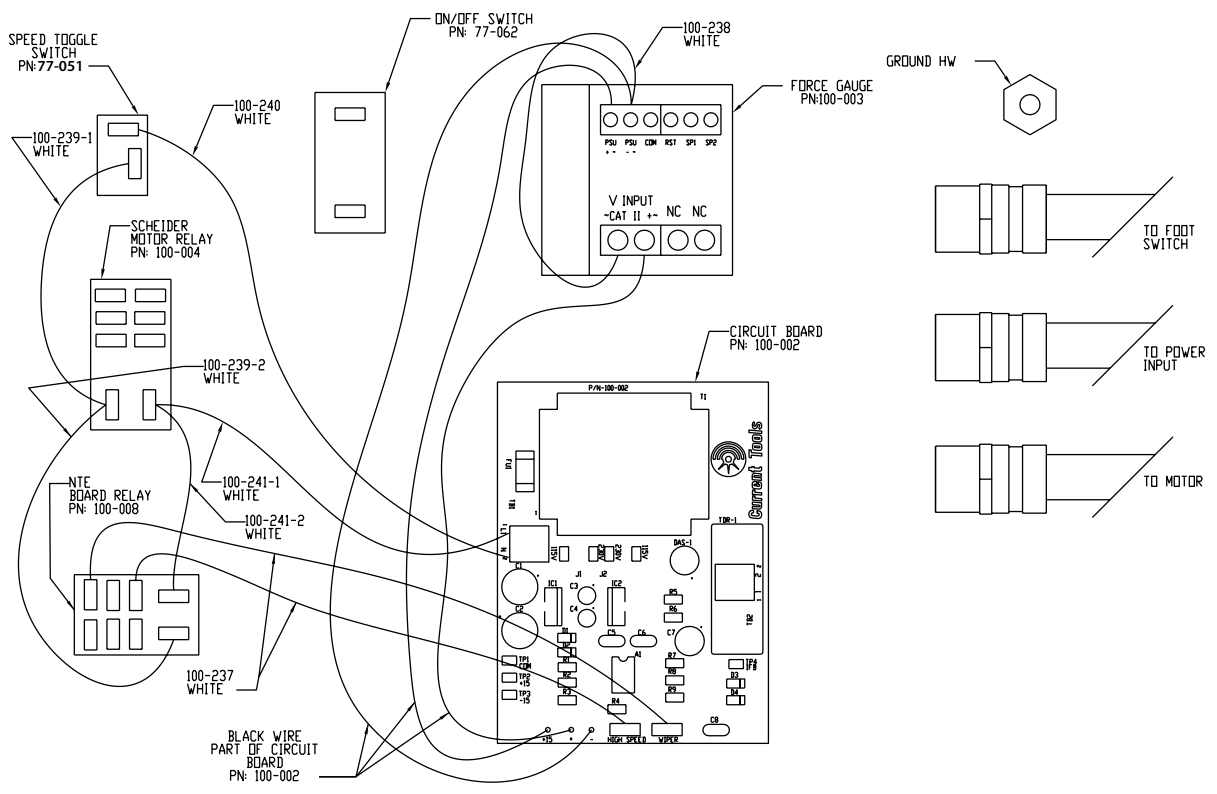

FROM FOOT SWITCH, POWER CORD AND MOTOR

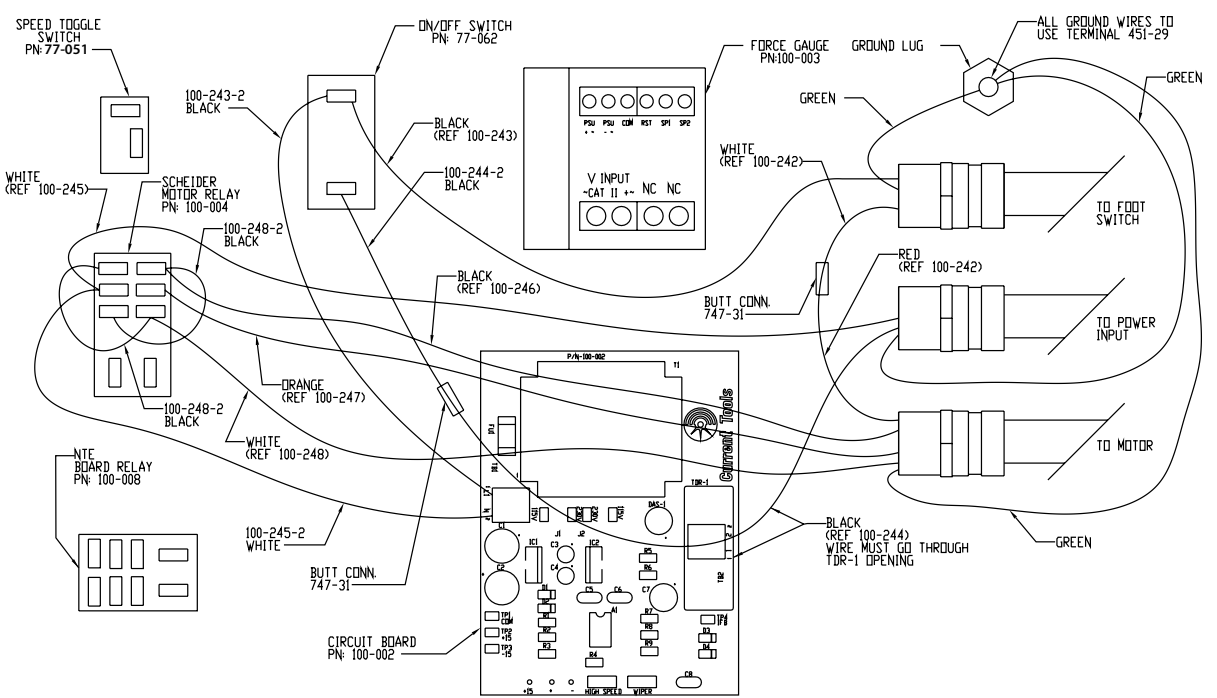

COMPONENT PARTS LISTING

SCREW-ON COUPLINGS

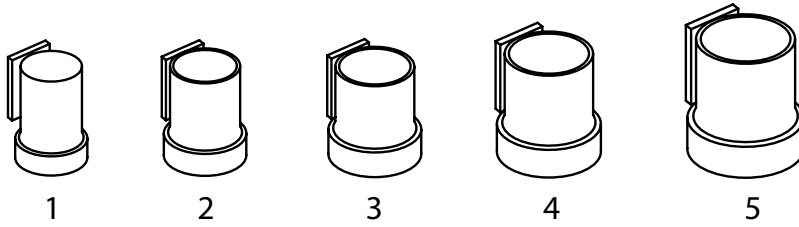

ITEM #	PART #	DESCRIPTION	QTY.
1	259	SCREW-ON COUPLING FOR 2" IMC, RIGID CONDUIT	<i>optional</i>
2	260	SCREW-ON COUPLING FOR 2 1/2" IMC, RIGID CONDUIT	<i>optional</i>
3	261	SCREW-ON COUPLING FOR 3" IMC, RIGID CONDUIT	<i>optional</i>
4	262	SCREW-ON COUPLING FOR 3 1/2" IMC, RIGID CONDUIT	<i>optional</i>
5	263	SCREW-ON COUPLING FOR 4" IMC, RIGID CONDUIT	<i>optional</i>

SLIP-IN COUPLINGS

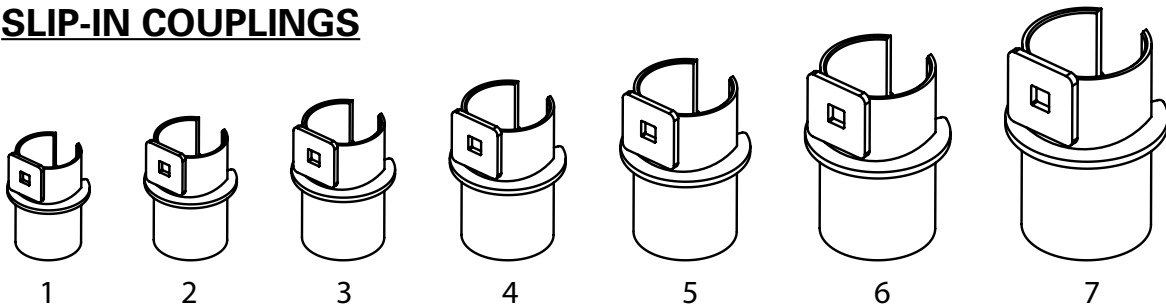

ITEM #	PART #	DESCRIPTION	QTY.
1	198	SLIP-IN COUPLING FOR 2" EMT, IMC, RIGID CONDUIT	1
2	199	SLIP-IN COUPLING FOR 2 1/2" EMT, IMC, RIGID CONDUIT	1
3	200	SLIP-IN COUPLING FOR 3" EMT, IMC, RIGID CONDUIT	1
4	201	SLIP-IN COUPLING FOR 3 1/2" EMT, IMC, RIGID CONDUIT	1
5	202	SLIP-IN COUPLING FOR 4" EMT, IMC, RIGID CONDUIT	1
6	230	SLIP-IN COUPLING FOR 5" EMT, IMC, RIGID CONDUIT	<i>optional</i>
7	255	SLIP-IN COUPLING FOR 6" EMT, IMC, RIGID CONDUIT	<i>optional</i>



COMPONENT PARTS LISTING — CONTINUED

FOUR WHEEL CARRIAGE – 1000

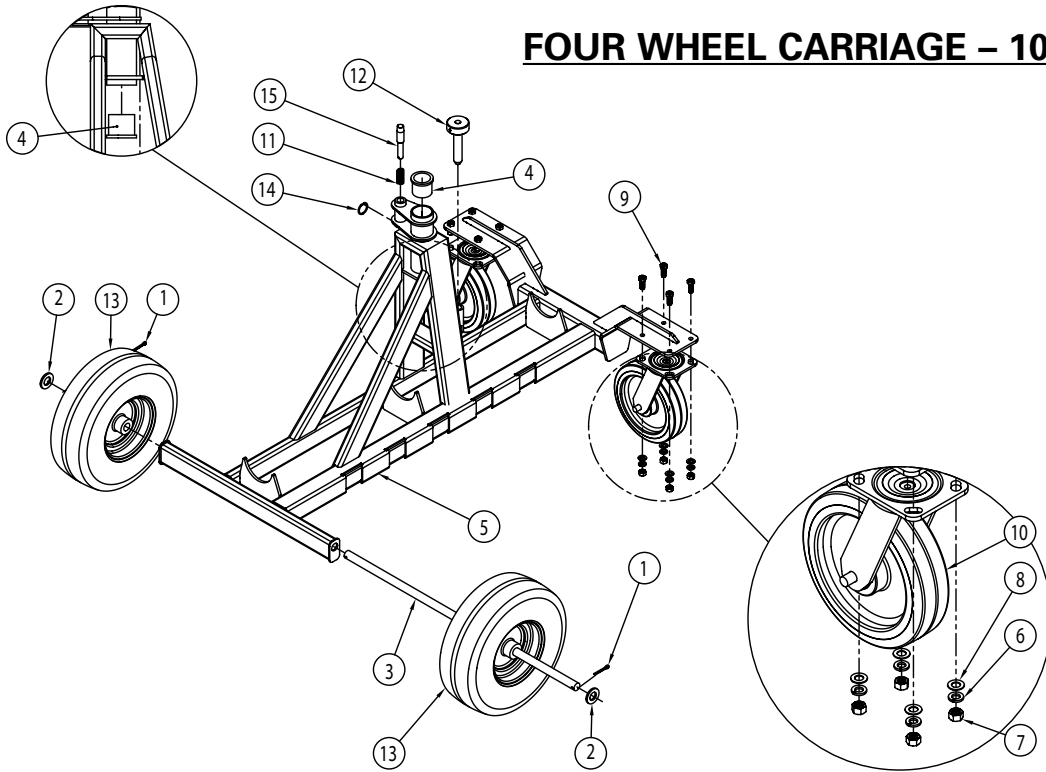

ITEM #	PART #	DESCRIPTION	QTY.
1	77-016	PIN – COTTER, 3/16" × 1 1/4"	2
2	77-017	WASHER – FLAT 3/4 SAE	2
3	77-429	AXLE	1
4	100-027	BUSHING – BASE	2
5	100-273	FRAME – CARRIAGE	1
6	452-27	WASHER – LOCK 3/8"	8
7	452-28	NUT – HEX, 3/8"	8
8	506-3	WASHER – FLAT, 3/8"	8
9	524-11	SCREW – HX HD CAP, 3/8-16 × 1"	8
10	747-1	CASTER – SWIVEL	2
11	747-4	SPRING	1
12	747-927	SCREW ASSEMBLY – LOCKING	1
13	8091-2	WHEEL	2
14	8099-3	BOOM PIN RING	1
15	747-860	PIN – POSITIONING	1

BOOM TUBES – 1850/1860

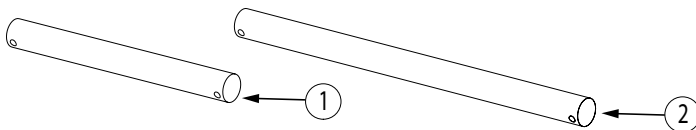

ITEM #	PART #	DESCRIPTION	QTY.
1	1850	3' BOOM TUBE	1
2	1860	4' BOOM TUBE	1



COMPONENT PARTS LISTING — CONTINUED

NOSE UNIT – 1840

ITEM #	PART #	DESCRIPTION	QTY.
1	33-22	SPRING-COUPLING MOUNT PAWL	1
2	33-485	PAWL-COUPLING MOUNT	1
3	100-011	BOOM PIN SPRING	1
4	100-170	BOOM PIN	1
5	100-172	NOSE UNIT OUTER	1
6	100-173	NOSE UNIT COUPLING ADAPTER	1
7	100-182	NOSE UNIT CUP ADAP ROLLER PIN	5
8	100-203	1 INCH PIN, NOSE UNIT	1
9	100-232	NOSE UNIT ROLLER PIN ASSEMBLY	5
10	406-3	SPRING CLIP	2
11	610-21	SCREW-BUTTON HEAD CAP (3/8-16 X 1)	10
12	951TR-10	ANGLE ADJUSTMENT PIN	1
13	8094-2A	ROLL PIN 3/16 X 1.5	2
14	8099-3	BOOM PIN RING	2

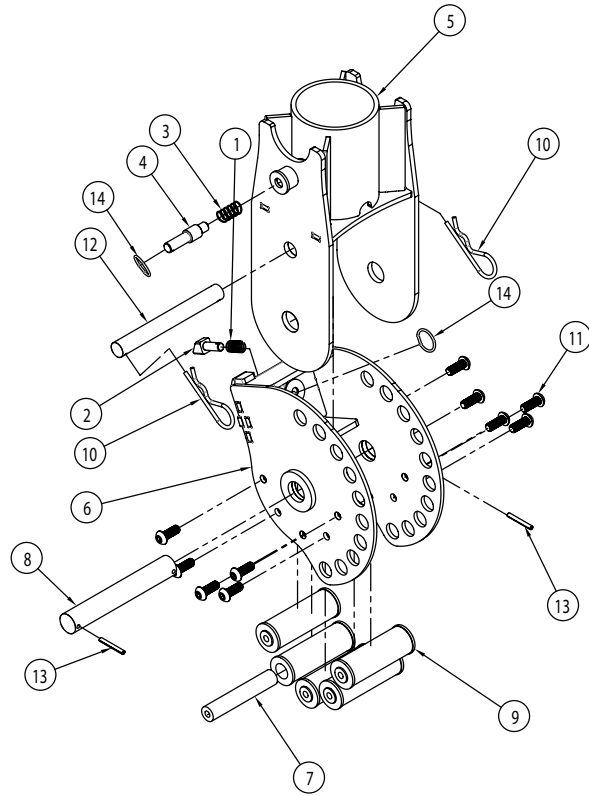

ELBOW UNIT – 1710

ITEM #	PART #	DESCRIPTION	QTY.
1	100-011	SPRING BOOM PIN	2
2	100-160	ELBOW UNIT OUTER	1
3	100-161	ELBOW UNIT INNER	1
4	333-212	ELBOW UNIT ANGLE ADJUSTMENT PIN	1
5	100-170	BOOM PIN	2
6	812-487	1 INCH PIN, ELBOW UNIT	1
7	100-219	SHEAVE ASSEMBLY	1
8	406-3	SPRING CLIP	2
9	8094-2A	ROLL PIN 3/16 X 1.5	2
10	8099-3	BOOM PIN RING	2

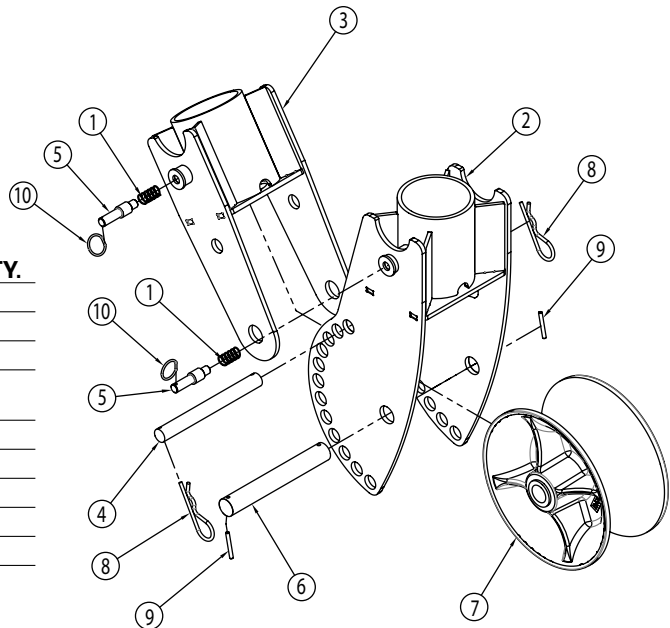



COMPONENT PARTS LISTING — CONTINUED

FLOOR MOUNT – 2280

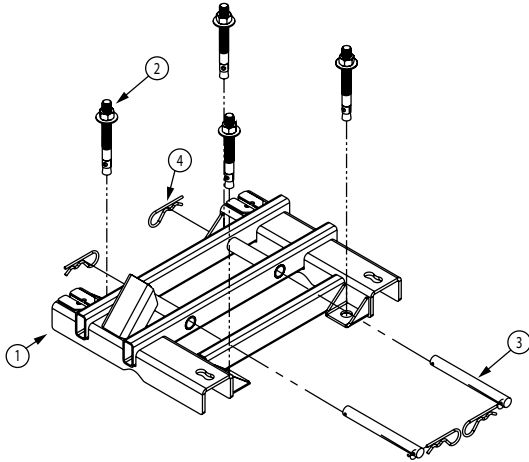

ITEM #	PART #	DESCRIPTION	QTY.
1	100-231	FLOOR MOUNT FRAME	1
2	8045-3	WEDGE ANCHOR	4
3	333-212	PIN – 3/4" × 7-3/8"	2
4	406-3	SPRING CLIP	4
5	2280-DECALSHEET	DECALS (NOT SHOWN)	1

CHAIN MOUNT – 2281

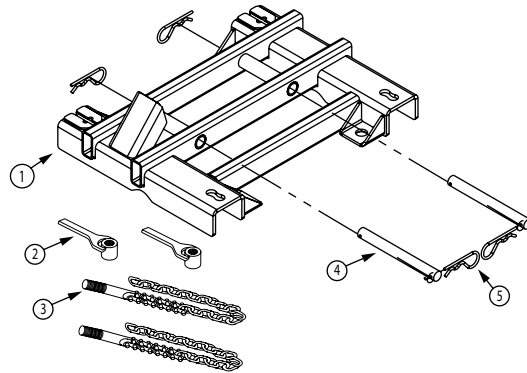

ITEM #	PART #	DESCRIPTION	QTY.
1	100-231	FLOOR MOUNT FRAME	1
2	88-42	CHAIN MOUNT HANDLE ASSEMBLY	2
3	88-21L	CHAIN MOUNT CHAIN ASSEMBLY	2
4	333-212	PIN, 3/4" × 7-3/8"	2
5	406-3	SPRING CLIP	4
6	2280-DECALSHEET	DECALS (NOT SHOWN)	1

PULLER MOUNT – 1190

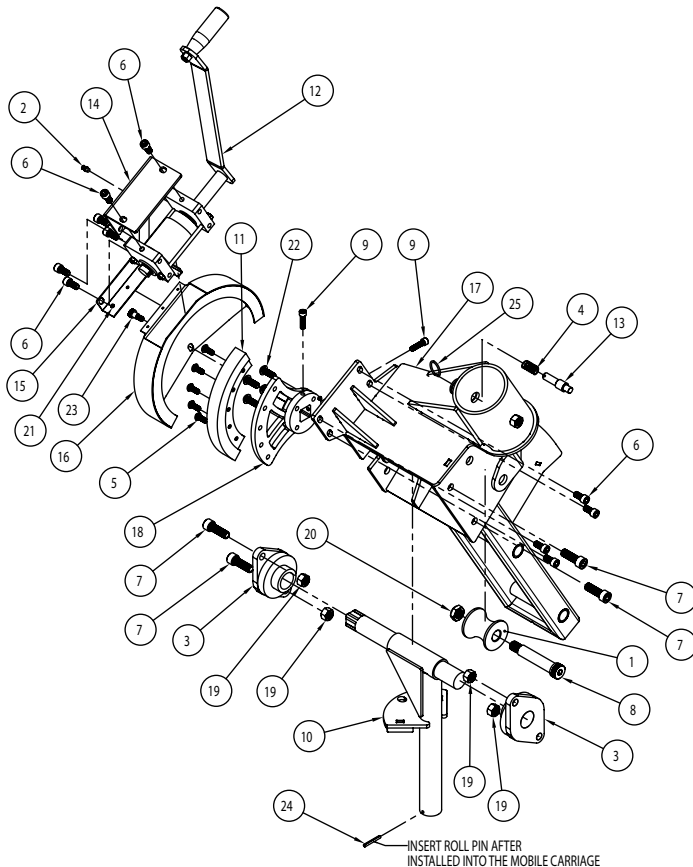

ITEM #	PART #	DESCRIPTION	QTY.
1	2-1005B	2 INCH PVC DELRIN BLACK	1
2	88-39	GREASE FITTING	1
3	100-005	ROTATION T SUPPORT	2
4	100-011	BOOM PIN SPRING	2
5	100-018	SCREW-BUTTON HEAD SOCKET (5/16-18 × 3/4)	5
6	100-019	SCREW-SOCKET HEAD CAP (3/8-16 × 3/4)	10
7	100-020	SCREW-SOCKET HEAD CAP (1/2-13 × 1.5)	4
8	100-021	SCREW-SHOULDER SOCKET (3/4-10 × 3.25)	1
9	100-025	SCREW-SOCKET HEAD CAP (5/16-18 × 1.125)	2
10	100-115	ROTATION T	1
11	100-152	GEAR SEGMENT	1
12	100-156	WORM BOX ASSEMBLY (SEE EXPLODED VIEW ON PAGE 41)	1
13	100-170	BOOM PIN	1
14	100-192	WORM COVER	1
15	100-210	GEAR HOUSING PLATE 1	1
16	100-217	GEAR HOUSING	1
17	100-265	PULLER HEAD	1
18	100-267	GEAR HUB AND PLATE WELDMENT	1
19	280-2G	NUT-HEX ZINC (1/2-13)	4
20	281-1I	NUT-HEX, NYLON INSERT 5/8-11	1
21	450-44A	RIVET - BLIND 1/8"	3
22	610-21	SCREW-BUTTON HEAD CAP (3/8-16 × 1)	4
23	752-100	3/8 X 3/8 LG SHOULDER BOLT	1
24	8094-2A	ROLL PIN 3/16 × 1.5	1
25	8099-3	BOOM PIN RING	1



COMPONENT PARTS LISTING — CONTINUED

WORM BOX ASSEMBLY – 100-156

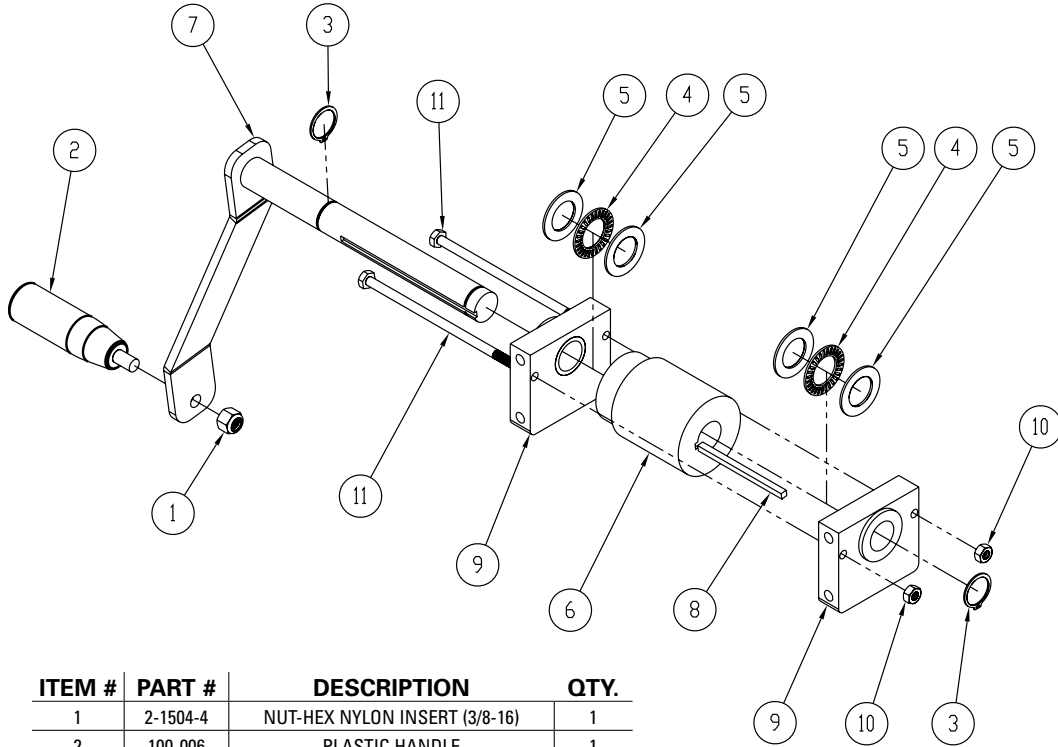

ITEM #	PART #	DESCRIPTION	QTY.
1	2-1504-4	NUT-HEX NYLON INSERT (3/8-16)	1
2	100-006	PLASTIC HANDLE	1
3	100-026	7/8 RETAINING RING - EXTERNAL	2
4	100-012	THRUST BEARING	2
5	100-013	THRUST RACE	4
6	100-016	WORM GEAR	1
7	100-233	WORM HANDLE WELDMENT	1
8	100-269	KEYSTOCK 3/16" x 3.125"	1
9	100-270	WORM BOX PLATE AND BUSHING	2
10	9518SR-12	NUT - HEX, NYLON INSERT (1/4-20)	2
11	95024RA-7	SCREW - HEX HEAD CAP GR5 ZINC (1/4-20 x 5.5)	2