

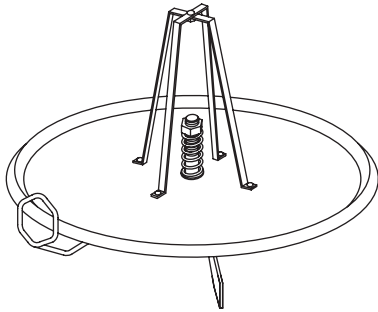

# ***Current Tools***

**FOR THE PROFESSIONAL ELECTRICIAN**

## **Current Tools™ Model 509 & Model 509M Romex & Armored Cable Dispensers**



*Model 509*

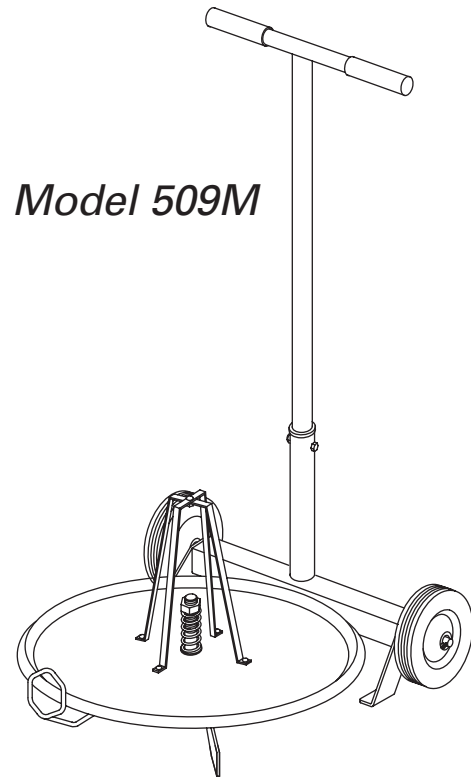

*Model 509M*

## **Operating, Safety, and Parts Manual**

07/10 – REV. 2



**Read and understand this material before operating the Cable Dispenser. Failure to understand how to safely operate this unit may result in injury or property damage.**

This manual is free of charge. All personnel who operate the Cable Dispensers should have a copy of this manual and read and understand its contents. To request a copy, call or write to the address below.

**CURRENT TOOLS • P. O. BOX 17026 GREENVILLE, SC 29606  
800.230.5421 or 864-721-4230 • FAX 864-721-4232  
[www.currenttools.com](http://www.currenttools.com)**

# TABLE OF CONTENTS

*Important Safety Information* . . . . . 2  
*Specifications* . . . . . 2  
*Features* . . . . . 3  
*Operating Instructions* . . . . . 3  
*Parts Lists* . . . . . 3-4

## RETAIN SAFETY INFORMATION



This manual should be read and understood by all personnel who operate the Cable Dispenser. Failure to understand how to safely operate this unit could result in injury or property damage. This unit should only be operated by qualified personnel.

# IMPORTANT SAFETY INFORMATION

Follow ALL safety information provided by the manufacturer.

- CAUTION** Do NOT stand on Cable Dispensers. They may become unstable and cause injury or damage to unit.
- CAUTION** Do NOT overload Cable Dispensers. Maximum dispensing capacity is 250 lbs.
- CAUTION** Do NOT attempt to transport the 509 Cable Dispenser with cable on it.
- CAUTION** ONLY transport cable reels to be dispensed on 509M Cable Dispenser. Transporting other loads may damage unit.
- CAUTION** Stay CLEAR of Cable Dispenser while in use.

<b>Model No.</b>	509	509M
<b>Dispensing Capacity</b>	250 lbs. — 1 coil 14/2, 14/3, 12/2 or 12/3 MC cable or 1 coil unboxed Romex <b>NOTE: Not for transporting cable</b>	250 lbs. — 1 coil of 14/2, 14/3, 12/2 or 12/3 MC cable or 1 coil unboxed Romex <b>NOTE: May transport up to 3 coils up to 250 lbs. total weight.</b>
<b>Unit Weight</b>	25 lbs.	48 lbs.
<b>Height</b>	26"	43"
<b>Length</b>	24"	35¼"
<b>Width</b>	24"	24½"

## FEATURES

- Sturdy steel construction for rugged use.
- Convenient T-handle and durable wheels on 509M for easy mobility.
- Fits through a standard doorway.
- Includes an adjustable spring to set the drag required and to prevent over-feeding.
- Cable guide pivots for tangle-free spooling in any direction.

## OPERATING INSTRUCTIONS

1. Remove all ties or straps from coil of wire or cable and position it on the turntable. ( For Romex, remove from box and place onto unit. )
2. Locate the end of the cable and pull it through the cable guide.
3. Set the desired drag by adjusting the hex nut at the top of the spring.
4. Prior to first use of 509M mobile unit, assemble handle to frame by inserting handle (Item #17) into frame (Item #12) and secure with hex head cap screw (Item #18) and hex nut (Item #19). *See exploded view on Page 4.*

## PARTS LIST — Model 509 Cable Dispenser

ITEM#	PART#	QTY	DESCRIPTION
1	509-267A	1	REEL STRAP
2	9544-15	5	$\frac{5}{16}$ -18 X 1" HEX HD SCREW
3	509-267B	1	REEL STRAP
4	509-3	1	1"-8 HEX NUT (NYLON INSERT)
5	509-2	1	SPRING COMPRESSION
6	509-271	1	TURN TABLE
7	509-266	1	MOUNTING PLATE
8	412-8	5	$\frac{5}{16}$ -8 HEX NUT
9	412-11	5	$\frac{5}{16}$ LOCK WASHER
10	509-272	1	CABLE GUIDE
11	509-15	1	WASHER - THRUST
12	509-585	1	FRAME
13	509C/M	1	DECAL - MODEL NO. AND CAUTION

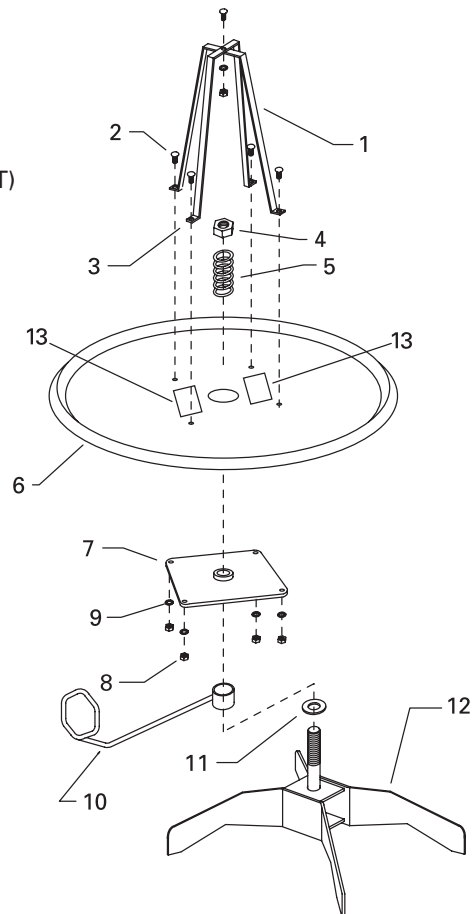



# PARTS LIST — Model 509M Mobile Cable Dispenser

<u>ITEM#</u>	<u>PART#</u>	<u>QTY</u>	<u>DESCRIPTION</u>
1.....	509-267A.....	1.....	REEL STRAP
2.....	9544-15.....	5.....	<sup>5</sup> / <sub>16</sub> -18 X 1" HEX HD SCREW
3.....	509-267B.....	1.....	REEL STRAP
4.....	509-3.....	1.....	1"-8 HEX NUT (NYLON INSERT)
5.....	509-2.....	1.....	SPRING COMPRESSION
6.....	509-271.....	1.....	TURN TABLE
7.....	509-266.....	1.....	MOUNTING PLATE
8.....	412-8.....	5.....	<sup>5</sup> / <sub>16</sub> -8 HEX NUT
9.....	412-11.....	5.....	<sup>5</sup> / <sub>16</sub> LOCK WASHER
10.....	509-272.....	1.....	CABLE GUIDE
11.....	509-15.....	1.....	WASHER - THRUST
12.....	509-583.....	1.....	FRAME
13.....	509M-C/M.....	2.....	DECALS – MODEL NO. AND CAUTION
14.....	509-13.....	2.....	WHEEL
15.....	501-14.....	2.....	COTTER PIN
16.....	504-1.....	2.....	GRIP
17.....	509-582.....	1.....	HANDLE
18.....	528-2.....	1.....	<sup>3</sup> / <sub>8</sub> -16 X 2" HEX HEAD SCREW
19.....	2-1501-4.....	1.....	<sup>3</sup> / <sub>8</sub> -16 HEX NUT (NYLON INSERT)

