

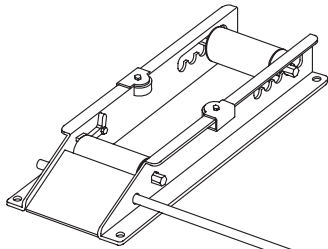

Current Tools
FOR THE PROFESSIONAL ELECTRICIAN

**Current Tools™ Model 610
& Model 613 Reel Rollers**



Model 610

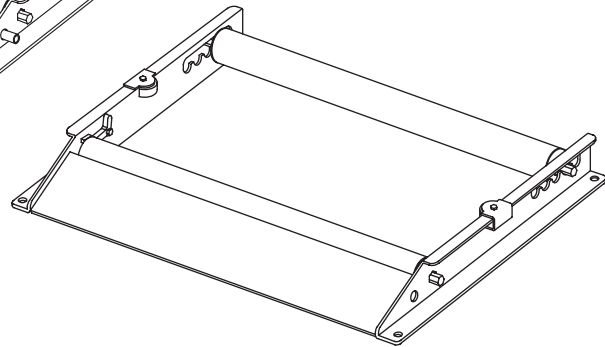
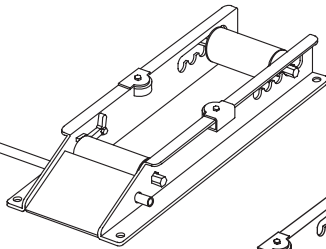

Model 613

Operating, Safety, and Parts Manual

01/08 - REV. 2



Read and understand this material before operating reel roller. Failure to understand how to safely operate this unit may result in serious injury or death.

This manual is free of charge. All personnel who operate the reel rollers should have a copy of this manual and read and understand its contents. To request a copy, call or write to the address below.

**CURRENTTOOLS • P. O. BOX 17026 GREENVILLE, SC 29606
800.230.5421 or 864.244.1201 • FAX 864.244.5860
www.currenttools.com**

RETAIN SAFETY INFORMATION



This manual should be read and understood by all personnel who operate the reel roller. Failure to understand how to safely operate this unit could result in injury or death. This unit should only be operated by qualified personnel.

IMPORTANT SAFETY INFORMATION

- ALWAYS keep hands and feet clear of cable reel when loading, unloading, and when dispensing cable.
- ALWAYS set reel roller on a firm, level surface. Reel rollers should only be used at ground level.
- ALWAYS disengage the roller stop pawl before dispensing the cable. Failure to do so may result in the reel of cable being pulled from the reel roller.
- ALWAYS have control of the reel of cable when loading or unloading.
- Keep the area free of personnel who are NOT involved with the loading, unloading, or dispensing process. Be aware that cable reels can be pulled off the reel roller during the dispensing process.
- ALWAYS dispense from the top of the reel. (See Figure 1)
- DO NOT attempt to dispense cable from reels that are damaged. Reels that are damaged may fail to roll freely and can be pulled off the reel roller.
- DO NOT attempt to stop a rotating reel with the roller stop pawl.

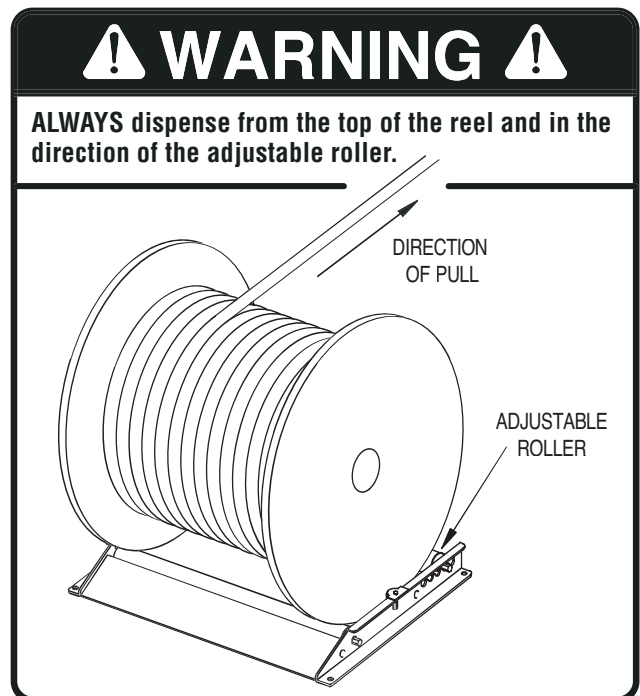

FIGURE 1

SPECIFICATIONS — 610 & 613 Reel Rollers

Model No.	610	613
Overall Dimensions	10 1/2" x 21 1/4" (each)	21 1/4" x 35 1/2"
Weight Capacity	2000 lbs. (per pair)	2500 lbs.
Maximum Reel Width	42"	30"
Weight	25 lbs. (each)	68 lbs.



OPERATING INSTRUCTIONS — 610 & 613 Reel Rollers

1. Anchor reel roller(s) to concrete floor with $\frac{1}{2}$ " or $\frac{3}{8}$ " anchor bolts. (Anchor bolts are provided by user.) There are 4 anchor holes on each reel roller frame.
2. Engage the roller stop pawl. (*See Figure 2a.*) Note: The roller stop pawl may be placed on the right or left inside as needed for easy accessibility.
3. Place reel on reel roller ensuring that you will dispense from the top of the reel and the pull direction is toward the adjustable roller. (*See Figure 1.*)
4. Disengage roller stop pawl. (*See Figure 2b.*)

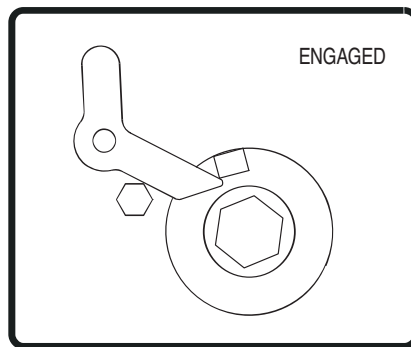

FIGURE 2a

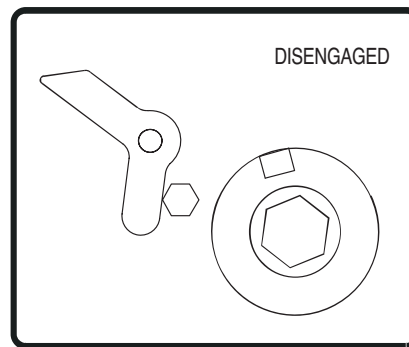

FIGURE 2b

5. Dispense cable.
6. Before removing reel from reel roller, place the roller stop pawl in the engaged position. (*See Figure 2a.*) Then remove reel from the reel roller.

NOTE: The Model 610 Reel Rollers are used in pairs. A 48" piece of $\frac{3}{4}$ " rigid conduit (provided by user) may be used to help with alignment. Alignment holes are provided in each model 610 reel roller. (*See Figure 3.*)

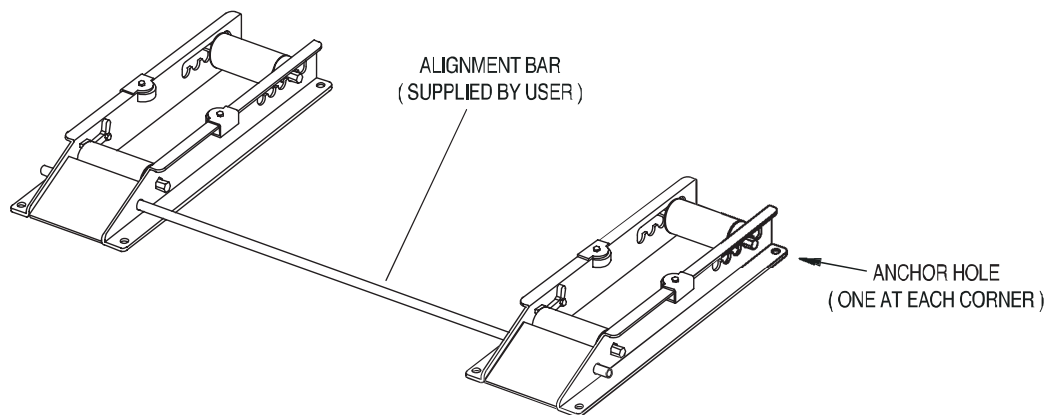
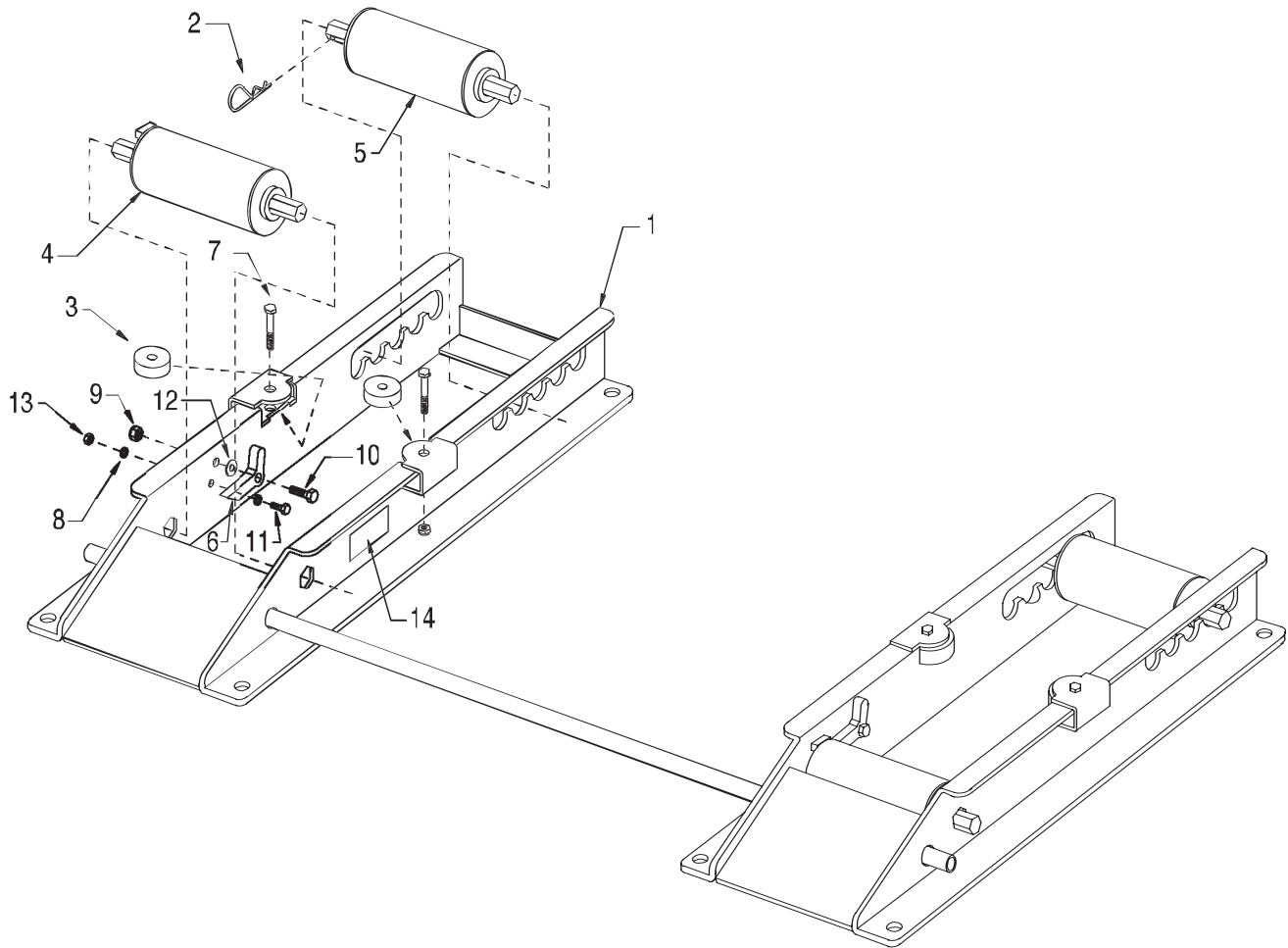

FIGURE 3

EXPLODED VIEW

610 REEL ROLLER



PARTS LIST — 610 Reel Roller

<u>ITEM #</u>	<u>PARTS #</u>	<u>QTY</u>	<u>DESCRIPTION</u>
1.....	610-18.....	1.....	MOUNTING FRAME
2.....	406-3.....	1.....	R-CLIP
3.....	610-24.....	2.....	WHEEL-2"
4.....	610-23A.....	1.....	ROLL ASSEMBLY-STOP
5.....	610-23.....	1.....	ROLL ASSEMBLY-ADJUSTABLE
6.....	610-2.....	1.....	PAWL-STOP
7.....	610-24A.....	2.....	SCREW-CAP, HEX HD 1/4-20 X 2"
8.....	450-14G.....	2.....	1/4" LOCK WASHER
9.....	2-1501-4.....	1.....	3/8-16 HEX NUT (NYLOK)
10.....	281-2D.....	1.....	SCREW-CAP, HEX HD 3/8-16 X 1 1/4"
11.....	450-1A.....	1.....	SCREW-CAP, HEX HD 1/4-20 X 3/4"
12.....	506-3.....	1.....	WASHER-FLAT, 3/8 USS
13.....	450-14C.....	1.....	NUT-HEX, 1/4-20
14.....	610-15.....	1.....	DECAL

EXPLODED VIEW

613 REEL ROLLER

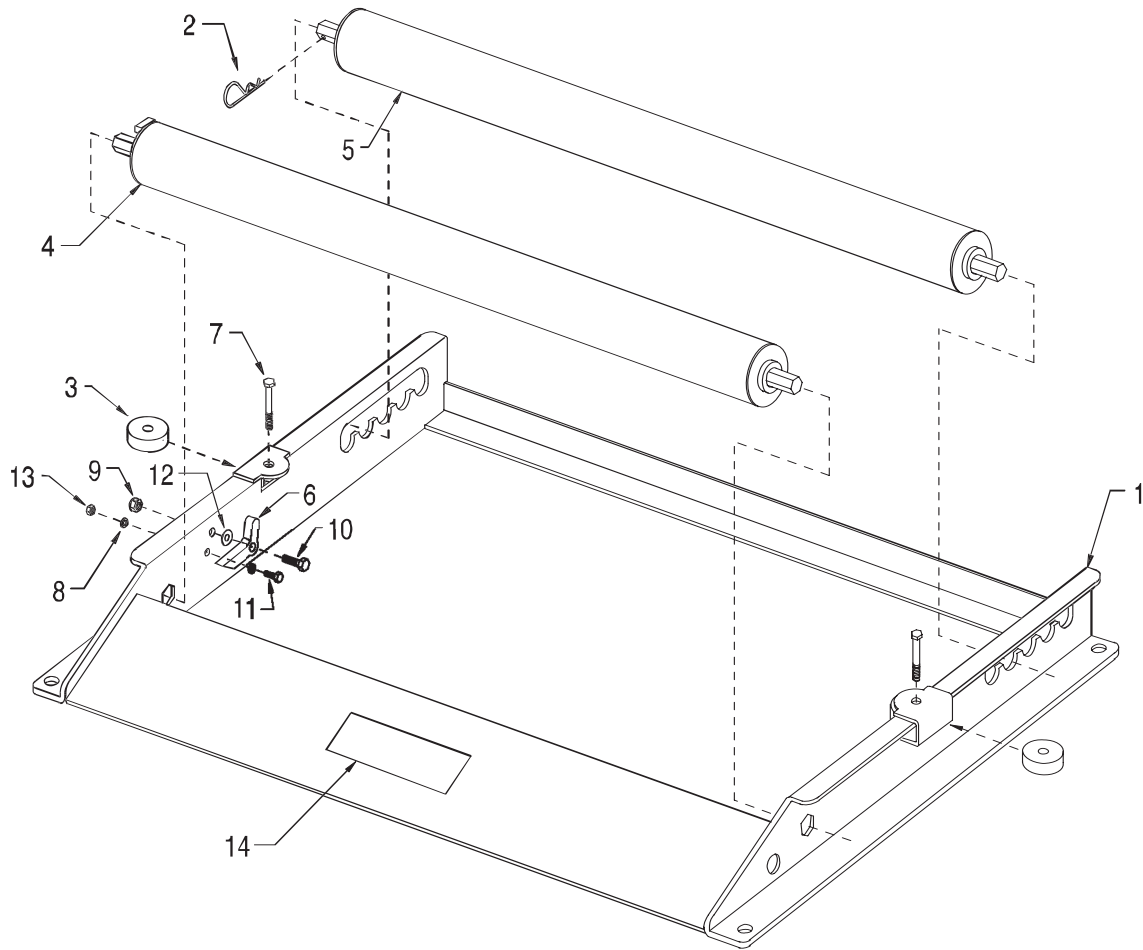

PARTS LIST — 613 Reel Roller

<u>ITEM #</u>	<u>PARTS #</u>	<u>QTY</u>	<u>DESCRIPTION</u>
1.....	613-6.....	1.....	MOUNTING FRAME
2.....	406-3.....	1.....	R-CLIP
3.....	610-24.....	2.....	WHEEL-2"
4.....	613-13.....	1.....	ROLL ASSEMBLY-STOP
5.....	613-12.....	1.....	ROLL ASSEMBLY-ADJUSTABLE
6.....	610-2.....	1.....	PAWL-STOP
7.....	610-24A.....	2.....	SCREW-CAP, HEX HD. 1/4-20 X 2"
8.....	450-14G.....	2.....	1/4" LOCK WASHER
9.....	2-1501-4.....	1.....	3/8-16 HEX NUT (NYLOK)
10.....	281-2D.....	1.....	SCREW-CAP, HEX HD, 3/8-16 X 1 1/4"
11.....	450-1A.....	1.....	SCREW-CAP, HEX HD, 1/4-20 X 3/4"
12.....	506-3.....	1.....	WASHER-FLAT, 3/8 USS
13.....	450-14C.....	1.....	NUT-HEX, 1/4-20
14.....	613-1.....	1.....	DECAL