



HOLEMAKING

Knockout Set for Stainless Steel 166SS – 2½", 3", 3½" and 4"

- 4 point punch design for easy slug removal
- Designed to punch a maximum of 10 gauge stainless steel
- Metal Case
- Made in the USA



Scan here for manual



Catalog Number	Description	Weight	
166SS	2½"- 4" Knockout Punch and Die Set for Stainless Steel	23 lbs.	UPC 811993024467



Current Tools
FOR THE PROFESSIONAL ELECTRICIAN

www.currenttools.com

P.O. Box 17026 • Greenville, SC 29606 • 864.721.4230 • fax 864.721.4232 • 800.230.5421



Knockout Punch and Die Set for Stainless Steel 166SS – 2½" to 4"

Item Number	Catalog Number	Description	UPC
1	1583	2½" SS Punch	811993024474
2	1584	2½" SS Die	811993024481
3	1585	3" SS Punch	811993024498
4	1586	3" SS Die	811993024504
5	1587	3½" SS Punch	811993024511
6	1588	3½" SS Die	811993024528
7	1589	4" SS Punch	811993024535
8	1590	4" SS Die	811993024542
9	1575	¾" x 5½" SS Draw Stud	811993021695
10	1580	1 1/8" Adapter Draw Stud	811993021114
11	1504	Metal Case	811993021206

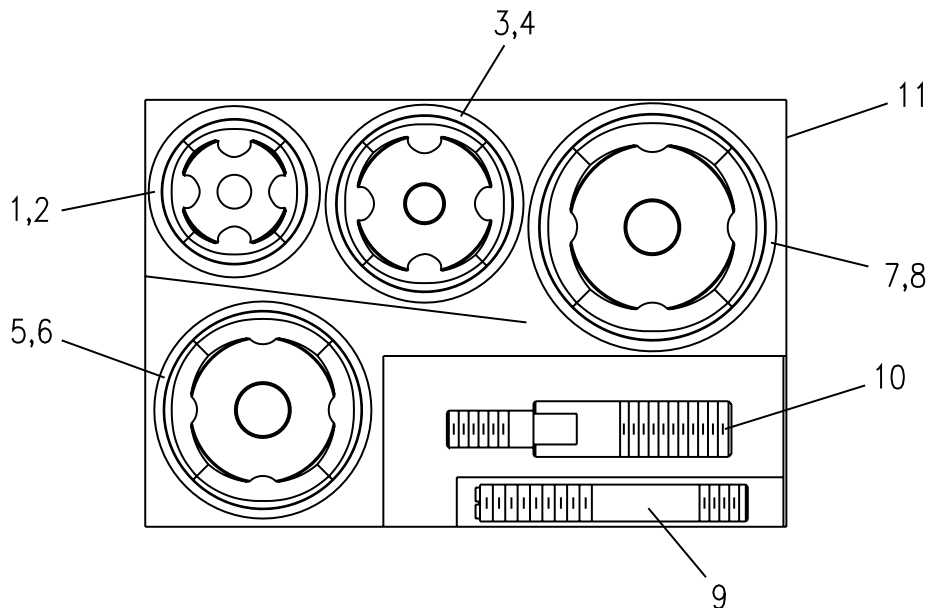

NOTE: Catalog #163-766 Die Adapter and Catalog #1580 Draw Stud are required to use the 3½" and 4" Punch and Die with the #165 Drill Driven Punch Driver.