

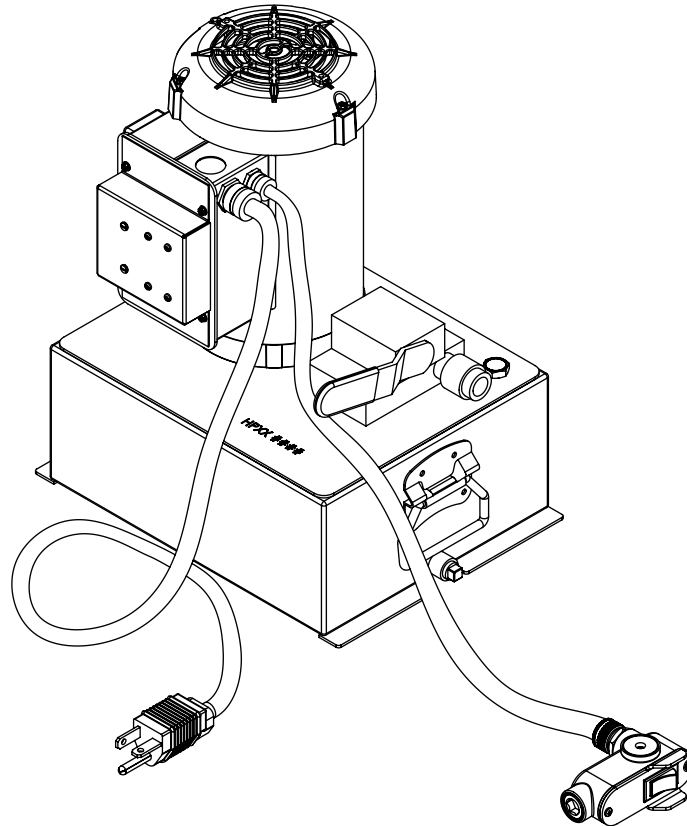

Current Tools

FOR THE PROFESSIONAL ELECTRICIAN

Model 292 Hydraulic Power Pump



Operating, Maintenance, Safety and Parts Manual



Read and understand this material before operating or servicing the Hydraulic Pump. Failure to understand how to safely operate and service this unit may result in serious injury or death.

09/2019

This manual is free of charge. All personnel who operate the Hydraulic Pump should have a copy of this manual and read and understand its contents. To request a copy of this manual, call or write to the address below or visit our website. All information, specifications and product designs may change due to design improvements or updates and are subject to change without notice. Current Tools does not assume any liability for damages resulting from misuse or incorrect application of its products.

CURRENT TOOLS • P. O. BOX 17026 GREENVILLE, SC 29606
800.230.5421 or 864-721-4230 • FAX 864-721-4232
www.currenttools.com



TABLE OF CONTENTS

<i>Safety Alerts</i>	3
<i>Important Safety Information</i>	4
<i>Specifications</i>	5
<i>Grounding Instructions</i>	6
<i>Operating Instructions</i>	7
<i>Electrical System Diagram</i>	8
<i>Maintenance</i>	9-11
<i>Exploded View and Parts List</i>	12-14
<i>Troubleshooting</i>	15



Safety Alert Symbol

THIS SAFETY SYMBOL is used to call your attention to instructions that concern your personal safety. It means: ATTENTION! BE AWARE! THIS IS AN IMPORTANT SAFETY INSTRUCTION!

Read, understand, and follow these safety instructions. Failure to follow these safety instructions may result in injury or death.

DANGER

Immediate hazards which, if not avoided, **WILL** result in serious personal injury or death.

WARNING

Hazards or unsafe practices which, if not avoided, **COULD** result in serious personal injury or death.

CAUTION

Hazards or unsafe practices which, if not avoided, **COULD** result in minor personal injury or property damage.

RETAIN SAFETY INFORMATION



This manual should be read and understood by all personnel who operate or service this Hydraulic Pump. Failure to understand how to safely operate and service this unit could result in serious injury or death. This unit should only be operated and serviced by qualified personnel.

IMPORTANT SAFETY INFORMATION

- ⚠ DANGER** ONLY use hoses and accessories that are rated for a minimum of 10,000 psi.
- ⚠ DANGER** NEVER operate the pump in an explosive atmosphere.
- ⚠ DANGER** NEVER operate the pump in wet or damp locations. DO NOT expose to rain.
- ⚠ WARNING** Hydraulic fluid under pressure can easily puncture skin causing serious injury.
- ⚠ WARNING** Read and understand the operating and safety manual for this pump prior to use.
- ⚠ WARNING** The pump has internal factory adjusted relief valves which must be repaired or adjusted by a factory technician. DO NOT alter these settings. Doing so will change the maximum pressure that the pump can develop which can cause component failure and injury to personnel.
- ⚠ WARNING** ALWAYS wear approved safety glasses when operating or servicing this pump.
- ⚠ WARNING** ALWAYS inspect the pump and all hoses, couplers and fittings before operating. Replace any damaged, missing or worn components with Current Tools parts.
- ⚠ CAUTION** ALWAYS check the hydraulic oil level in the reservoir prior to using the pump. An insufficient oil level will result in damage to the pump.
- ⚠ CAUTION** The pump exceeds 50 lbs. and will require more than one person to lift and transport.
- ⚠ CAUTION** Avoid damage to the hydraulic hose. DO NOT drop heavy objects onto the hose or lift, move or carry any hydraulic equipment with the hose.
- ⚠ CAUTION** DO NOT operate or store hydraulic equipment near flames or high heat.
- ⚠ CAUTION** BEFORE adding hydraulic oil to the reservoir, fully retract the cylinder to return all hydraulic oil in the system back to the reservoir. Check fluid level and add as necessary. DO NOT overfill. An overfill can cause excessive pressure and possible damage to the equipment as well as injury to personnel.
- ⚠ CAUTION** Check all hose connections prior to use and ensure they are properly connected. Improper connections may not allow the hydraulic cylinder to retract after the bend is complete.
- IMPORTANT** To depressurize the hydraulic system, first, unplug the power cord. Then, rotate the pump valve lever to the open position and allow the hydraulic cylinder to fully retract. Slowly disconnect the hydraulic hose.



SPECIFICATIONS

The Current Tools Model #292 Hydraulic Power Pump is designed to be used with single acting hydraulic cylinders rated for 10,000 P.S.I.

length	15 1/2"
width	11 1/2"
height	18"
weight	89 lbs. — empty 106 lbs. — with oil

Power Requirements: 120V AC, 60HZ, single phase, 20 amps

Motor Data: 1 1/2 HP
1725 RPM

Pump Output: Fast advance – 480 cubic inches per minute
at 150 P.S.I.
Full pressure – 56 cubic inches per minute
at 10,000 P.S.I.

Hydraulic Oil: Full capacity 9.5 quarts
Usable capacity 8 quarts

NOTE: ONLY fill with AW32 or equivalent hydraulic oil.
DO NOT use brake fluid.

ATTENTION: This pump is shipped from the factory with an unvented fill plug to prevent leakage. Prior to use, remove the unvented plug and install the vent plug provided. Failure to install the vent plug will result in poor performance.

GROUNDING INSTRUCTIONS

WARNING

ELECTRIC SHOCK HAZARD! Only connect the hydraulic pump to a 20 AMP GFCI protected circuit. **DO NOT** modify the plug which is provided with the unit. Failure to follow these warnings can result in serious injury or death.

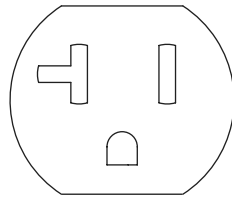

RECEPTACLE

Figure 9a

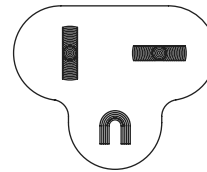

PLUG

Figure 9b

In the event of a malfunction or breakdown, grounding provides a path of least resistance for electric current to reduce the risk of electric shock. The hydraulic pump is equipped with an electric cord having an equipment grounding conductor and a grounding plug. Only connect the pump to a 20 AMP GFCI protected receptacle which is properly installed and grounded to meet all applicable electrical codes. Do NOT use an adapter.

Do NOT modify the plug provided. If it will not fit the receptacle, have the proper receptacle installed by a qualified electrician.

Improper connection of the equipment grounding conductor can result in risk of electric shock. The conductor with insulation having an outer surface that is green with or without yellow stripes is the equipment grounding conductor. If repair or replacement of the electric cord or plug is necessary, do not connect the equipment grounding conductor to a live terminal.

Check with a qualified electrician or service personnel if the grounding instructions are not completely understood, or if in doubt as to whether the hydraulic pump is properly grounded.

Use only 3-wire extension cords that have 3-prong grounding plugs and 3-pole receptacles that accept the pump's plug.

Repair or replace damaged or worn cord immediately.

This pump is intended for use on a circuit that has a receptacle that looks like the one illustrated in Figure 9a above. The pump has a grounding plug that looks like the plug illustrated in Figure 9b above.

OPERATING INSTRUCTIONS



Read and understand the operating and safety manual for this pump prior to use.

⚠ DANGER NEVER operate the pump in an explosive atmosphere.

⚠ DANGER NEVER operate the pump in wet or damp locations. DO NOT expose to rain.

⚠ WARNING Hydraulic fluid under pressure can easily puncture skin causing serious injury.

⚠ WARNING ALWAYS wear approved safety glasses when operating or servicing this pump.

ATTENTION: This pump is shipped from the factory with an unvented fill plug to prevent leakage. Prior to use, remove the unvented fill plug and install the vent plug provided. Failure to install the vent plug will result in poor performance.

IMPORTANT: Starting the motor without the cylinder properly attached to the pump will cause the pump to immediately build an internal pressure of 10,000 P.S.I. To depressurize the hydraulic system, first unplug the power cord then rotate the valve lever to the open position and allow the hydraulic cylinder to fully retract. Slowly disconnect the hydraulic hose.

1. Ensure the unvented fill plug that was used during shipping has been removed and the vented fill plug provided has been installed.
2. Check the oil level in the reservoir. Add approved hydraulic oil if necessary. (See "Adding Hydraulic Oil" section on page 10).
3. Rotate the pump valve lever to the open position.
4. Ensure that the hose and couplings are clean and free of debris prior to assembly.
5. Attach the hydraulic hose to the coupling assembly on the hydraulic cylinder and the coupling on the hydraulic pump. Hand tighten all connections firmly. DO NOT use tools.
6. Plug the pump into the correct power supply.

To advance the hydraulic cylinder

1. Rotate the pump valve lever to the closed position.
2. Depress the jog switch on the pendant assembly.

To retract the hydraulic cylinder

Rotate the pump valve lever to the open position to release the pressure

Removing the hydraulic cylinder

Prior to removing the hydraulic cylinder that is connected to the pump, the system must be depressurized.

1. Unplug the power cord.
2. Rotate the pump valve lever to the open position and allow the hydraulic cylinder to fully retract.
3. Slowly disconnect the hydraulic hose.



ELECTRICAL SYSTEM DIAGRAM

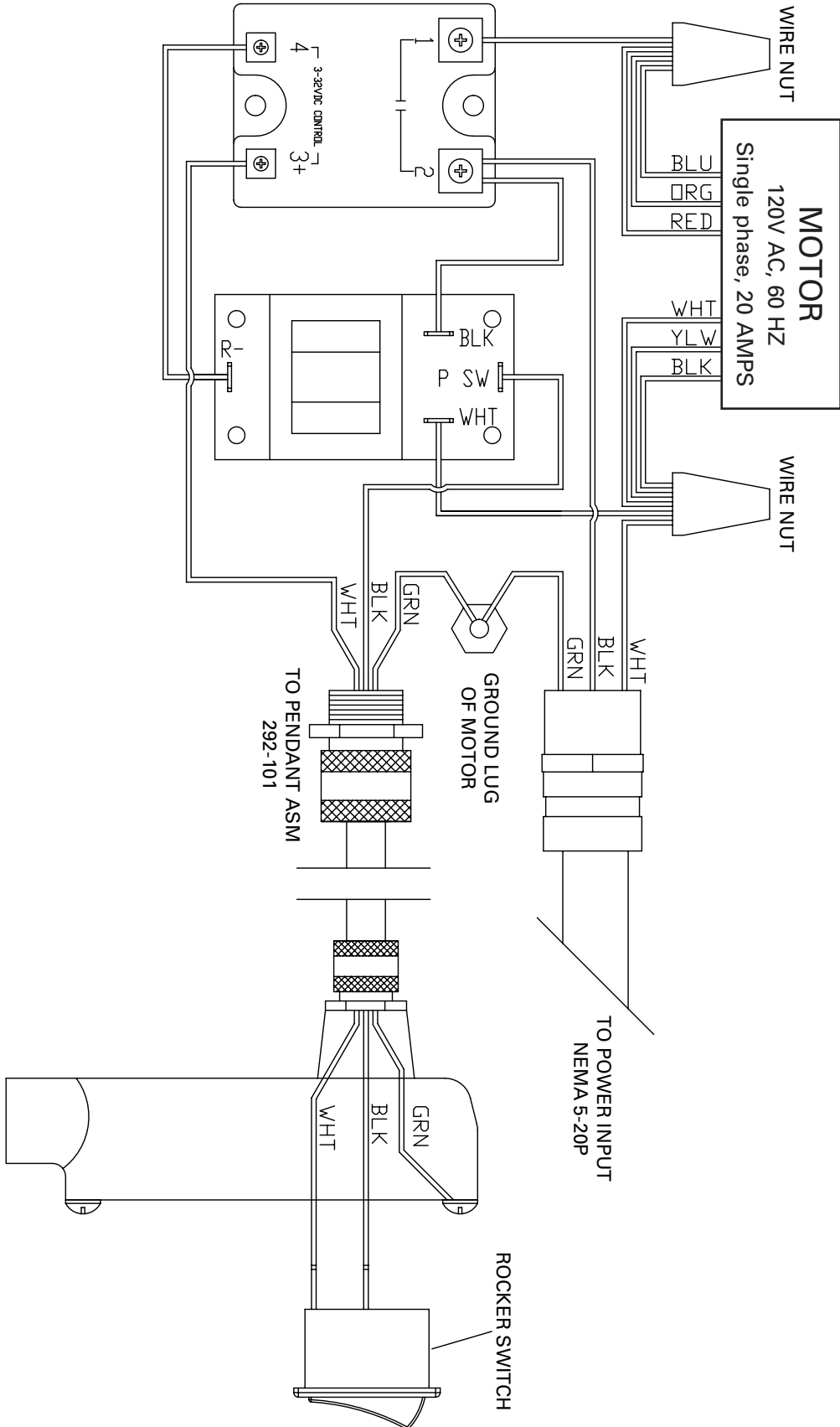



MAINTENANCE



WARNING

Unplug the hydraulic pump prior to performing any service on the pump.

IMPORTANT

Prior to performing service on the pump, the system must be depressurized. To depressurize, first unplug the power cord. Then, rotate the pump valve lever to the open position and allow the hydraulic cylinder to fully retract. Slowly disconnect the hydraulic hose.

BEFORE EACH USE:

- Ensure the vented fill plug has been installed and is in place.
- Check the oil level in the reservoir. Add approved hydraulic oil if necessary. (See “Adding Hydraulic Oil” section on page 10).
- Ensure that the hose and all couplings are clean, free of debris and not worn or damaged. Replace if necessary.
- Ensure that all electrical cords, plugs, connectors, etc. are not worn or damaged. Replace if necessary.
- Pay attention to unusual sounds or other changes in performance that may indicate a need for maintenance or repairs.

REGULARLY

- Check the hydraulic oil in the reservoir for discoloration, changes in viscosity, dirt or other contaminants. These conditions most likely indicate a need to replace the oil. Failure to change the oil when needed can damage system components.
- Wipe down the exterior of the pump, motor and reservoir and vacuum all ventilation openings.
- Ensure the vented fill plug in the reservoir is clean and not obstructed by debris.



MAINTENANCE — CONTINUED

ADDING HYDRAULIC OIL:

*Use only an AW32 or equivalent hydraulic oil. DO NOT use brake fluid.

- 1) Unplug the power cord.
- 2) Rotate the pump valve lever to the open position and allow all oil in the system to flow into the reservoir.
- 3) Make sure the area around the vented fill plug is clean.
- 4) Remove the vented fill plug.
- 5) Using approved hydraulic oil as noted above, pour the oil through a clean funnel with a filter screen into the reservoir.
- 6) Fill the reservoir until it is approximately 2" from the top of the reservoir.
- 7) Re-install the vented fill plug.

REMOVING AIR FROM THE SYSTEM (BLEEDING):

- Air trapped in the hydraulic system can cause inconsistent performance. Follow the steps below to bleed the trapped air from the system.



CAUTION

DO NOT start the pump motor without the cylinder properly attached to the pump. DO NOT attempt to operate the pump to full pressure by restricting the travel of the hydraulic cylinder (Dead Heading).

IMPORTANT

The hydraulic cylinder should not be advanced more than 3/4 of its full stroke.

NOTE: Make sure the vented fill plug is installed on the pump reservoir prior to performing the bleeding process.

- 1) Remove the hydraulic cylinder from the bender frame.
- 2) Ensure the cylinder is properly connected to the hydraulic pump with a hose rated for 10,000 p.s.i.
- 3) Secure the hydraulic cylinder in the vertical position with the hose coupler facing up. The cylinder should be positioned lower than the pump if possible.
- 4) Rotate the pump valve lever to the closed position.



MAINTENANCE — CONTINUED

- 5) Operate the pump to advance the cylinder, stopping the pump once the cylinder has traveled 3/4 of its full stroke. DO NOT overextend the cylinder.
- 6) Rotate the pump valve lever to the open position. This will force air in the system to move through the pump reservoir and out of the vented fill plug.
- 7) Ensure proper oil level. Add approved hydraulic oil if necessary. (See “Adding Hydraulic Oil” section on page 10).

DRAINING AND FLUSHING:

NOTE: Ensure the pump exterior is clean prior to draining and flushing.

- 1) Drain the reservoir by removing the drain plug located at the bottom of the reservoir. Once the oil has drained from the reservoir, reinstall the drain plug and tighten.
- 2) Remove the pump motor from the reservoir.
- 3) Wipe the interior of the reservoir to clean.
- 4) Unscrew the filter screen from the bottom of the pump motor and clean. Re-install after cleaning.
- 5) Re-install the pump motor onto the reservoir and tighten all screws.
- 6) Remove the vented fill plug and fill the reservoir with new hydraulic oil to within 2" of the top.
- 7) Next, you will need a hose with a coupler on one end and open on the other end. Connect the coupler on the hose to the coupler on the pump.
- 8) Insert the open end of the hose into the reservoir fill hole.
- 9) Rotate the pump valve lever to the closed position and operate the pump for 1 to 2 minutes so that the clean oil circulates through the system.
- 10) Stop the pump and rotate the pump valve lever to the open position. Remove the hose from the pump and reservoir fill hole.
- 11) Drain the reservoir as noted in Step #1.
- 12) Refill the reservoir according to the instructions in the “Adding Hydraulic Oil” section on page 10.

EXPLODED VIEW AND PARTS LIST

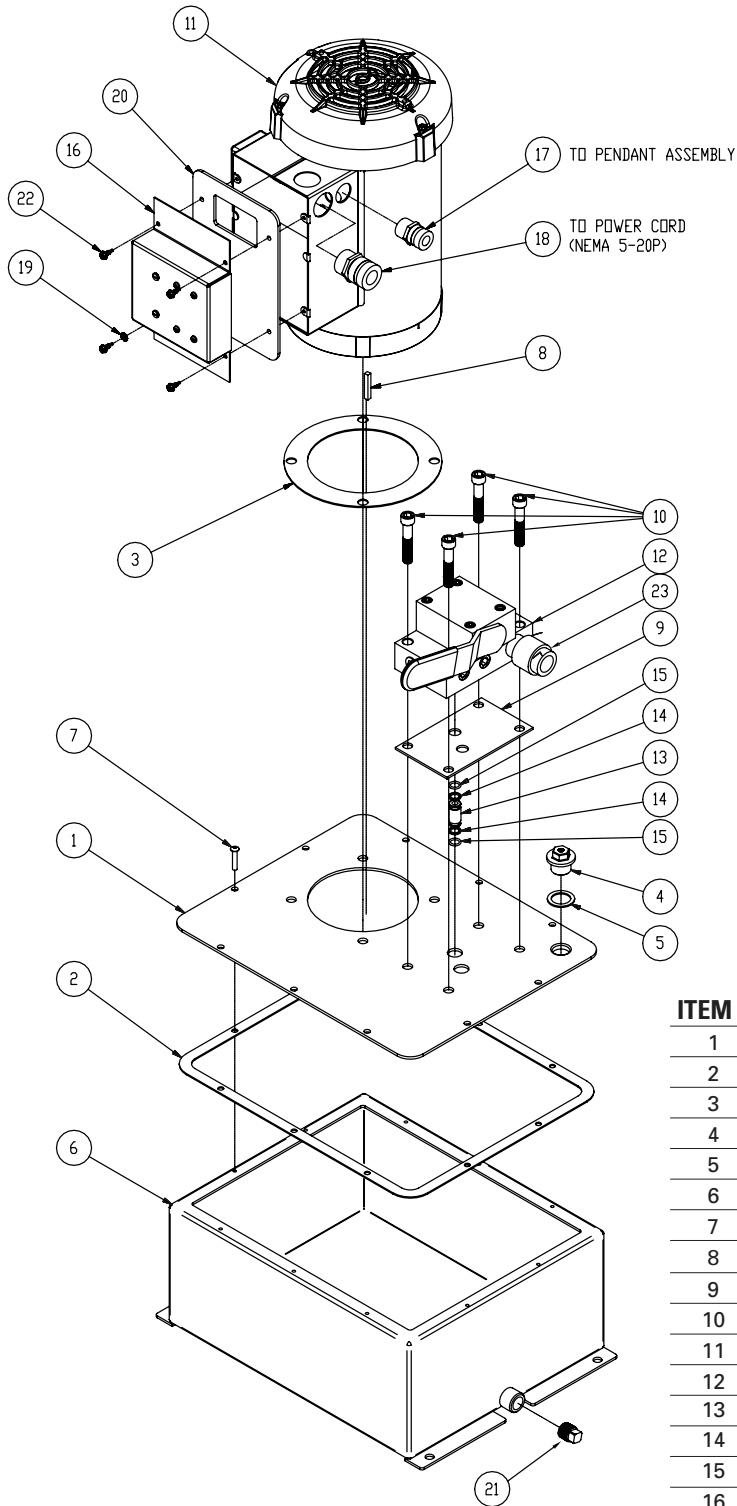

ITEM #	PART #	DESCRIPTION	QTY.
1	BP1007	RESERVOIR COVER PLATE	1
2	X-7443-1	RESERVOIR GASKET	1
3	X-7439	GASKET, MOTOR TO COVER	1
4	X-7445-1	RESERVOIR PLUG - VENT	1
5	X-7445	NYLON WASHER	1
6	X7931-MOD	SINGLE SPEED RESERVOIR	1
7	2220555	BHCS 10-24 x 1.0	10
8	X-9505	KEY 3/16 SQ x 1 1/4 LG	1
9	BP1008	VALVE GASKET	1
10	2220600	SHCS 3/8-16 x 2	4
11	292-001	MOTOR - HYD. PUMP	1
12	X12-158	VALVE LEVER ASSEMBLY	1
13	BP1044	CONNECTOR	1
14	X-7878-10	BACK-UP RINGS	2
15	X-6477-57	O-RING .504 x .364 x .06 70D	2
16	292-103	BOX COVER ASSEMBLY	1
17	292-011	STRAIN RELIEF - PENDANT	1
18	292-012	STRAIN RELIEF - POWER CORD	1
19	747-39	WASHER, LOCK - #8 EXT. TOOTH	1
20	292-010	GASKET - BOX	1
21	2470172	PLUG - DRAIN	1
22	77-004A	SCREW - HX FLANGE, 8-32	4
23	291-2A	COUPLER - HYDRAULIC	1



EXPLODED VIEW AND PARTS LIST

ITEM #	PART #	DESCRIPTION	QTY.
1	BP1013	HIGH PRESSURE PLATE GASKET	1
2	X-6862	THRUST BEARING	1
3	X-6863	BEARING RACE	2
4	BP1015-1	ECCENTRIC SHAFT	1
5	BP1018	BEARING I KO#BR162416	1
6	BP1020-A	BEARING RACE THICK (TWA 1018)	1
7	BP1020-C	BEARING RACE THIN (TWC 1018)	1
8	BP1020	THRUST BEARING (TC 1018)	1
9	H-4360	WOODRUFF KEY	1
10	BP1021	SNAP RING	1
11	BP1047	TUBE FITTING (90 DEG)	1
12	BP1037	1/4-20x2" SHCS	6
13	BP-1036	LOW PRESS. PLATE (3 PISTON)	1
14	BP6063	GEROTOR ASSEMBLY	1
15	BP1038	GEROTOR HOUSING	1
16	2470339	PIPE PLUB 1/8 NPTF	3
17	BP1049	TUBE FITTING (STRAIGHT)	1
18	BP1048	TUBING	1
19	BP1040	HHCS 5/16-18	3
20	2350167	CONDUIT LOCKNUT 3/8	2
21	BP1055-A	HIGH PRESSURE PLATE ASSEMBLY	1
22	BP1022-A	PISTON BLOCK ASSEMBLY	3
23	BP1002	SHCS 3/8-16 x 1-3/4	4
24	X-9488	FILTER ADAPTER	1
25	X-8226	FILTER DISC	2
26	X-7454	FILTER ADAPTER PLATE	1
27	X-7382	FILTER SCREEN PLATE	1
28	X-7383	FILTER SCREEN	1
29	2220601	BHCS 10-24 x 3/4	3

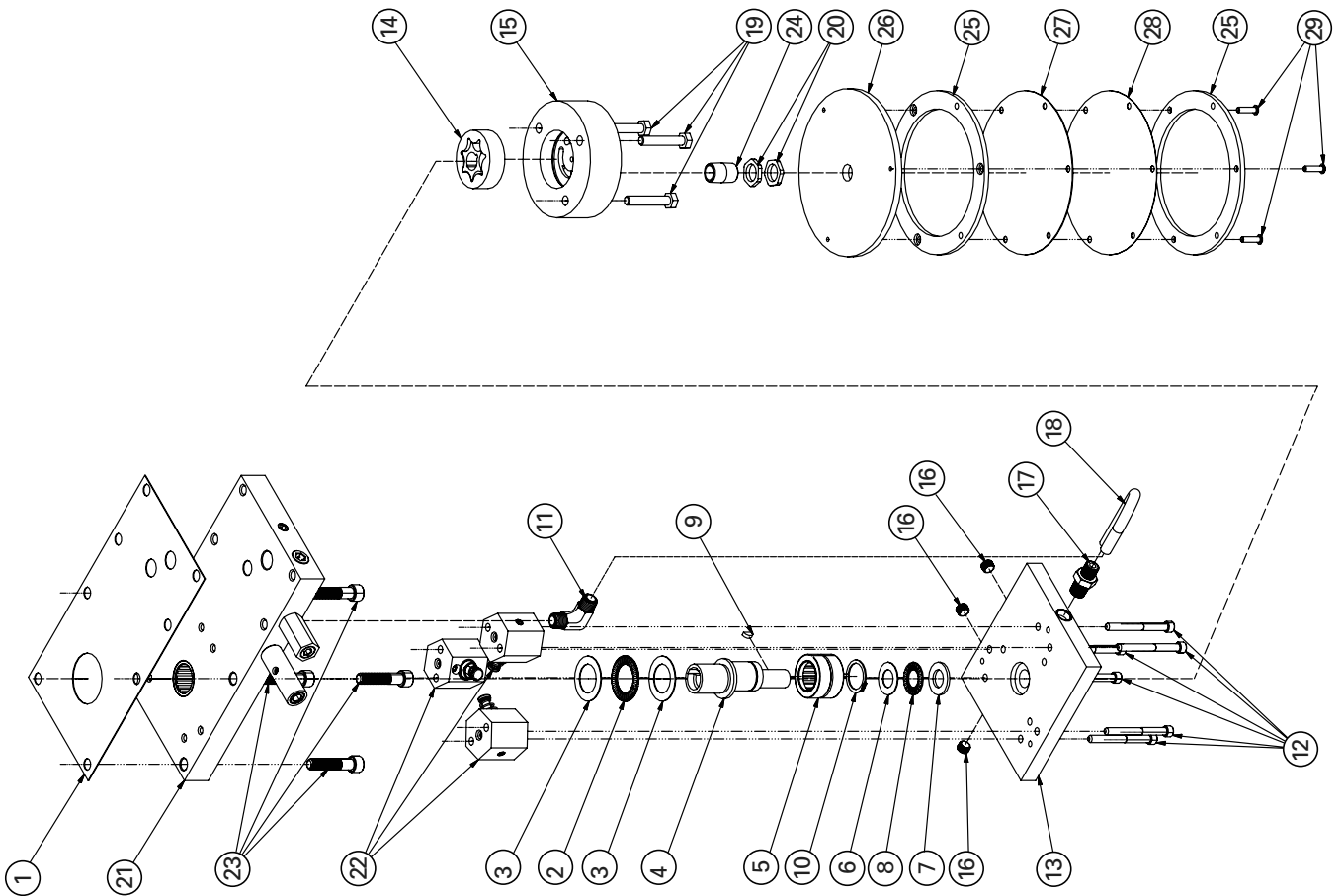

EXPLODED VIEW AND PARTS LIST

ITEM #	PART #	DESCRIPTION	QTY.
1	292-110	COVER – MOTOR	1
2	99-98	TRANSFORMER	1
3	99-99	SOLID STATE RELAY	1
4	292-006	SPACER	4
5	77-061	SCREW – PAN HEAD SLOT (6–32 × 3/8)	4
6	77-053	SCREW – PAN HEAD SLOT (8–32 × 3/8)	2
7	77-036A	NUT – HEX ZINC (#6–32)	4
8	453-16A	NUT – HEX ZINC (#8–32)	2

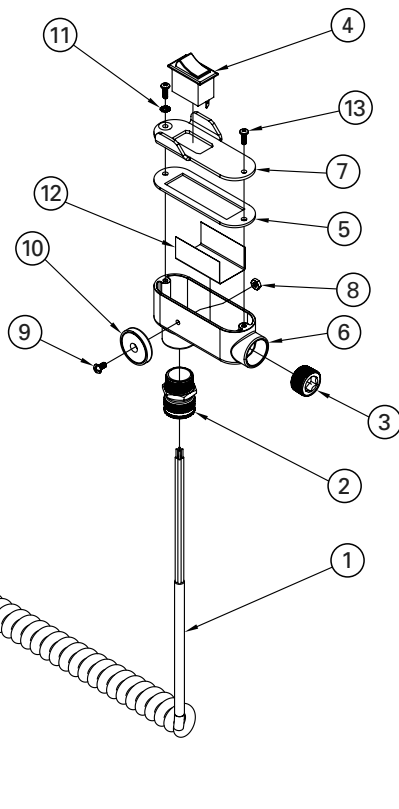
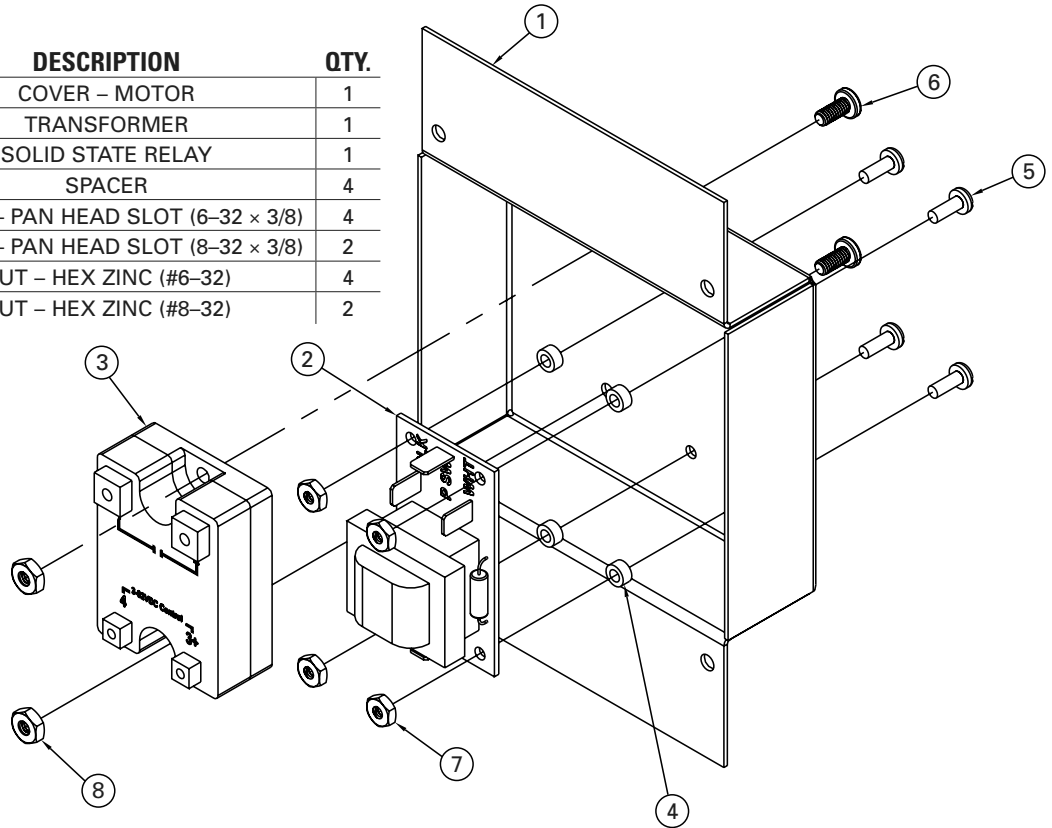

ITEM #	PART #	DESCRIPTION	QTY.
1	292-004	PENDANT CORD – COILED	1
2	292-012	CORD GRIP	1
3	292-008	PLUG – HEX 3/4 NPT	1
4	292-009	ROCKER SWITCH	1
5	292-106	GASKET – LARGE PENDANT	1
6	292-107	PENDANT BODY – 3/4" LB	1
7	292-109	PENDANT COVER	1
8	451-21	NUT – HEX ZINC (#10–32)	1
9	451-22	10–32 X .37 SCREW, MACH. SLOTTED	1
10	747-19	MAGNET	1
11	747-39	WASHER, LOCK – #8 EXT. TOOTH	1
12	77-065	FISH PAPER – INSULATING	1
13	77-072	SCREW – ROUND HEAD PHILLIPS (8–32 × 1/2")	2
14	77-3B	QUICK DISCONNECT	2
15	77-3D	TERMINAL – RING	1

WARNING

ALWAYS disconnect power supply before removing any guards or covers and before servicing this pump. Failure to do so may result in serious injury or death.

Problem	Cause	Cure
Motor does not start or motor stops under load	No power being supplied to motor	Check voltage at power supply
	Voltage supplied to motor is too low	Check voltage at power supply
	Improper extension cord used	Replace extension cord with a properly rated extension cord
	Damage to pendant, transformer or relay	Inspect and replace as necessary
Cylinder will not advance or advances slowly	Reservoir fill plug is blocked or incorrect	Remove the unvented fill plug and replace with vented fill plug or clean the vented fill plug
	Insufficient oil level	Add oil according to the "adding approved hydraulic oil" section in this manual
	Improper oil used or oil is dirty	Replace oil with an approved type as listed in the "adding approved hydraulic oil" section this manual
	Pump valve lever is not fully in the closed position	Rotate the pump valve lever to the fully closed position
	Pump filter screen is clogged	Clean the filter screen according to the "draining and flushing" section in this manual
	Hydraulic couplers are not properly engaged	Check all couplers and ensure they are fully seated and secure
	Hydraulic oil leak – external	Replace hose or couplers
	Hydraulic oil leak – internal	Return to factory for repair
	External relief valve set too low	Tighten relief valve as needed
Erratic cylinder movement	Air trapped in the hydraulic system	Bleed air from the system according to the "removing air from the system" section in this manual