

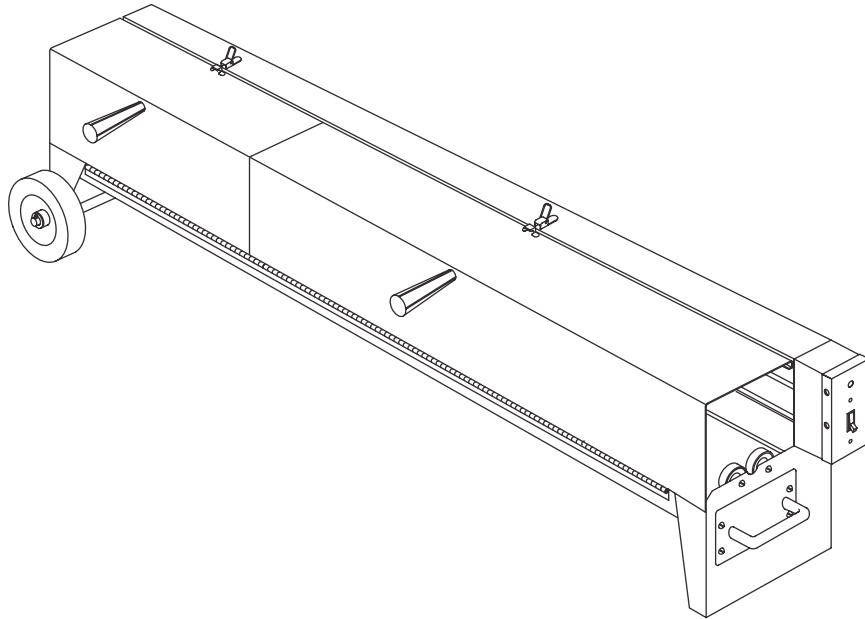

# ***Current Tools***

**FOR THE PROFESSIONAL ELECTRICIAN**

## **Current Tools™ Model 452 1/2" to 6" PVC Heater with Manual Rotation**



## **Operating, Maintenance, Safety and Parts Manual**



Read and understand this material before operating or servicing this PVC heater. Failure to understand how to safely operate and service this unit may result in serious injury or death.

This manual is free of charge. All personnel who operate or service this PVC heater should have a copy of this manual and read and understand its contents. To request a copy, call or write to the address below. All information, specifications and product designs may change due to design improvements or updates and are subject to change without notice. Current Tools does not assume any liability for damages resulting from misuse or incorrect application of its products.

**CURRENT TOOLS • P. O. BOX 17026 GREENVILLE, SC 29606  
800.230.5421 or 864.721.4230 • FAX 864.721.4232  
[www.currenttools.com](http://www.currenttools.com)**

## RETAIN SAFETY INFORMATION



This manual should be read and understood by all personnel who operate or service this PVC heater. Failure to understand how to safely operate and service this unit could result in injury or death. This unit should only be operated by qualified personnel.

## IMPORTANT SAFETY INFORMATION

- ALWAYS wear hand protection when operating this equipment and when bending PVC conduit. Use handle to open and close the PVC heater door(s).
- DO NOT use in wet conditions. DO NOT expose to rain or moisture.
- DO NOT use near flammable materials.
- DO NOT leave PVC heater unattended.
- Turn PVC heater off when not in use.
- Use for heating PVC conduit only. DO NOT use for any other purpose.
- Use only for PVC conduit sizes specified.
- Operate only in a well ventilated area.
- Use only with a grounded power source.

*The electric plug on this PVC heater includes a grounding conductor and is the twist to lock type as shown. Only connect the unit to a 30 AMP receptacle which is properly installed and grounded to meet all applicable electrical codes. Do NOT remove or modify the plug in any way.*

### **! WARNING !**

**ELECTRIC SHOCK HAZARD!** Only connect this PVC Heater to a 30 AMP, properly grounded receptacle. Do NOT modify the plug which is provided with the unit. Failure to follow these warnings can result in serious injury or death.

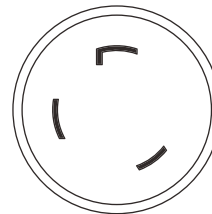

LOCKING PLUG

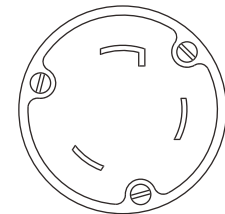

RECEPTACLE

## SPECIFICATIONS — 452 PVC Heater

<b>Model No.</b>	- 452 — Manual Rotation
<b>Capacity</b>	- 1/2" to 6" PVC conduit
<b>Power</b>	- 230 volts AC - Single Phase, 28 amps, 60 hz, 6400 watts
<b>Dimensions</b>	- 11 5/8" x 15 7/8" x 74"
<b>Weight</b>	- 72 lbs.

## MATERIALS NEEDED

- Sponge or clean cloth
- Bucket with clean water
- Insulated gloves



## OPERATING INSTRUCTIONS — 452 PVC Heater

1. Place PVC conduit heater on a flat, dry surface. Plug heater into a grounded power source. Turn switch to ON position.
2. Put on insulated gloves.
3. After warm-up period, ( approximately 7 min. ) place conduit on rollers inside the heater. Using handle, close door(s) over the section of PVC conduit to be heated.
4. Slowly rotate conduit by hand until pliable. To test, lift one end of the PVC conduit. Conduit is ready when it has a glossy appearance and bends when lifted.

**NOTE: PVC conduit MUST be rotated to provide even heating and to prevent scorching.**

**NOTE: PVC conduit will take approximately 30 seconds to heat for each 1/2" of PVC conduit diameter. ( Example: 2" PVC conduit will heat in approximately 2 minutes.)**

5. Open the heater door(s) using the handle and remove conduit from heater and place on a clean, flat surface. Hand bend to desired angle. The bend can be set by allowing to air cool or decrease this time by rubbing the bend with a sponge soaked in cool water. NOTE: Be sure to keep all liquids away from the PVC heater and turn unit off when not in use.



## PVC CONDUIT HEATER ACCESSORIES

- To prevent flattening and crimping during the bending process, CurrentTools *plug sets* are recommended for 2" and larger PVC conduit.
- CurrentTools Model #454 PVC support stand is recommended to prevent sagging of the conduit during the heating process.

### WIRING SCHEMATIC

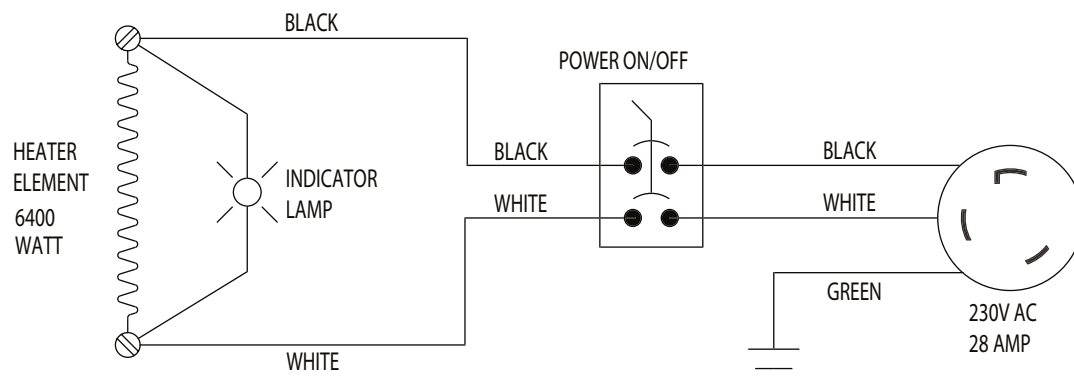

# EXPLODED VIEW 452 PVC HEATER

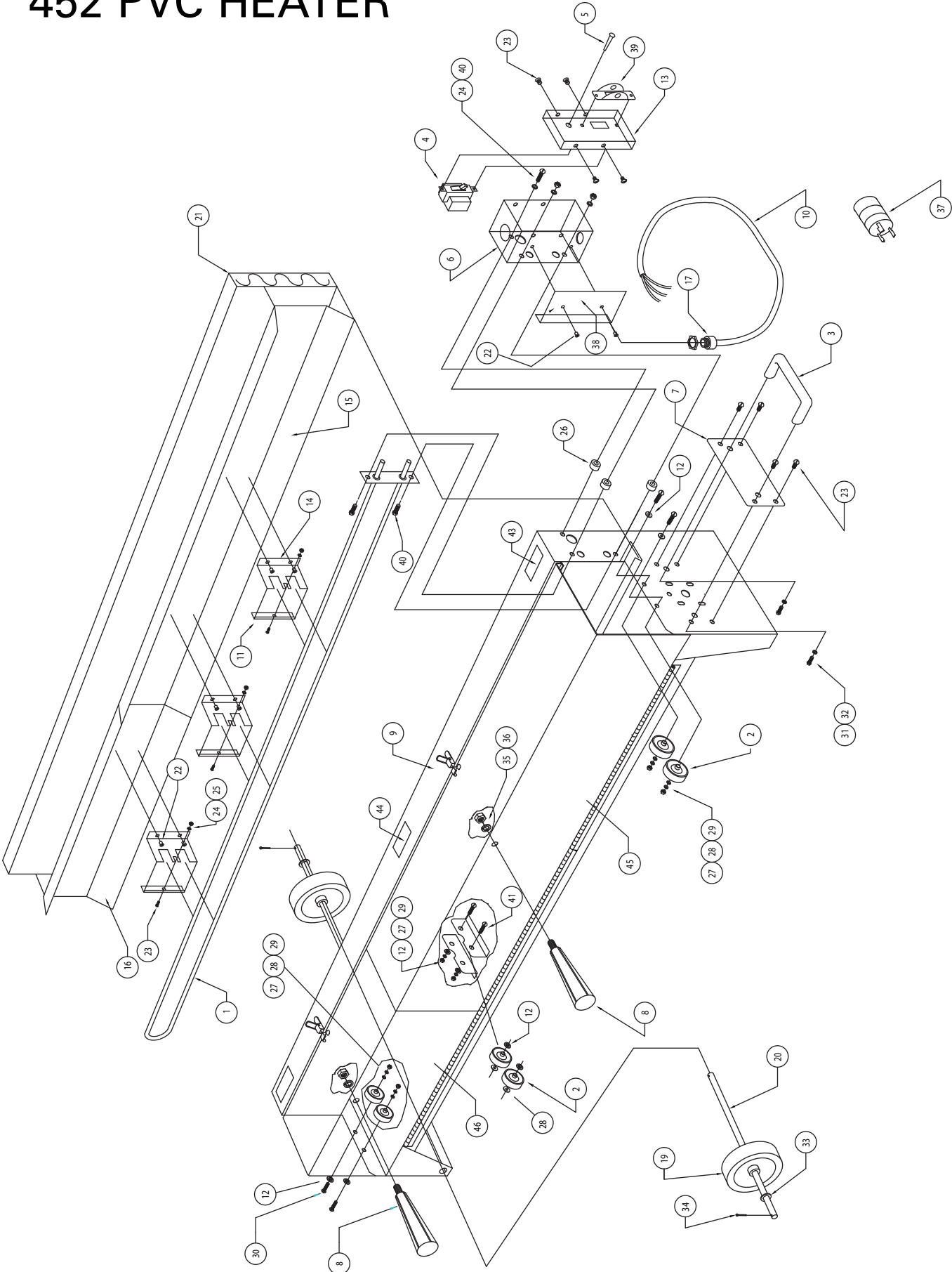



# PARTS LIST – 452 PVC HEATER

ITEM#	PART #	QTY	DESCRIPTION
1	452-1	1	HEATING ELEMENT
2	9518SR-9	6	SKATE WHEEL
3	450-11	1	LIFT HANDLE
4	452-19	1	SWITCH
5	452-20	1	INDICATOR LIGHT
6	452-6	1	ELECTRICAL BOX
7	452-13	1	COVER PLATE (HANDLE)
8	452-18	2	DOOR HANDLE
9	452-30	1	MAIN HOUSING FAB
10	452-31	1	POWER CORD
11	452-15	3	RETAINER CLIP
12	452-22	8	ADAPTER BUSHING
13	452-5	1	COVER-ELEC. BOX
14	452-14	3	RETAINER BRACKET
15	452-046 BENT	1	HEAT SHIELD-LONG
16	452-047 BENT	1	HEAT SHIELD-SHORT
17	452-21	1	STRAIN RELIEF
18	452-719	2	JUMPER WIRE – 6" (NOT SHOWN)
19	451-13	2	WHEEL
20	452-26	1	AXLE
21	450-9	1	INSULATION-2" THICK ( 10"W x 70"L )
22	450-28A	8	RIVET-3/16 x 1/4 SS
23	451-22	11	SCREW - PAN HD PHILLIPS 10-32 x 3/8"
24	450-14J	6	#10 FLAT WASHER
25	451-21	6	#10-32 HEX NUT
26	450-20	3	SPACER
27	450-14G	6	1/4" LOCK WASHER
28	450-14I	6	1/4" FLAT WASHER
29	450-14C	6	1/4-20 HEX NUT
30	450-29	4	SCREW – PAN HD PHILLIPS 1/4-20 x 1 1/4"
31	450-11A	2	HEX HD. CAP SCREW M8 x 12
32	450-11B	2	M8 LOCK WASHER
33	77-017A	2	1/2" FLAT WASHER
34	451-23	2	COTTER PIN
35	452-27	2	3/8 LOCK WASHER
36	452-28	2	3/8-16 HEX NUT
37	452-29	1	POWER PLUG
38	452-33	1	HEAT SHIELD
39	452-19A	1	SWITCH PROTECTOR
40	452-6D	3	SCREW –PAN HD PHILLIPS 10-32 x 3/4"
41	452-1B	2	SLOTTED MACH. SCREW 1/4-20 x 1 1/2"
42	452-23	1	DECAL – INSTRUCTION (NOT SHOWN)
43	452-24	1	PLATE – METAL, SERIAL NUMBER
44	450-34	1	PLATE – METAL, CAUTION "HOT"
45	452-7	1	DOOR – LARGE
46	452-042	1	DOOR – SMALL