



Current Tools

FOR THE PROFESSIONAL ELECTRICIAN

MODEL 254

Hydraulic Conduit Bender

for bending 2½" thru 4"
RIGID - EMT - IMC Conduit

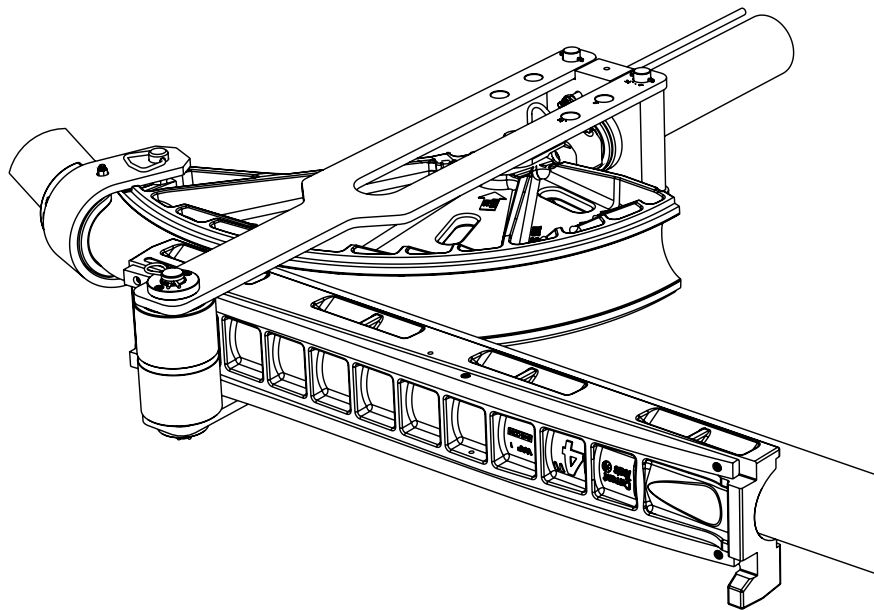

Assembly, Operating, Maintenance, Safety and Parts Manual

1/2019



Read and understand this material before assembling, operating or servicing this Hydraulic Bender. Failure to understand how to safely assemble, operate and service this unit may result in serious injury or death.

This manual is free of charge. All personnel who assemble, operate or service this Hydraulic Bender should have a copy of this manual and read and understand its contents. To request a copy, call or write to the address below. All information, specifications and product designs may change due to design improvements or updates and are subject to change without notice. Current Tools does not assume any liability for damages resulting from misuse or incorrect application of its products.

CURRENT TOOLS • P. O. BOX 17026 GREENVILLE, SC 29606
800.230.5421 or 864.721.4230 • FAX 864.721.4232
www.currenttools.com



TABLE OF CONTENTS

<i>Safety Alerts</i>	3
<i>Important Safety Information</i>	4,5
<i>Specifications</i>	6
<i>Major Components – Bender</i>	6
<i>Major Components – Parts List</i>	6
<i>Major Components – Shoe Groups</i>	7
<i>Conduit Centerline Bending Radii</i>	7
<i>Assembly & Operating Instructions</i>	8-13
<i>90° Bending Information and Charts</i>	14, 15
<i>Cylinder Travel and Bender Calibration</i>	16
<i>Common Bends Layout</i>	17-19
<i>Values for Layout of Common Bends</i>	20-23
<i>Calculating “C” Values for Offsets Past An Obstacle</i>	24
<i>Exploded View and Parts Lists – Follow Bars</i>	25
<i>Exploded View – Saddles</i>	26
<i>Explode View & Parts List – Hydraulic Cylinder</i>	27
<i>Troubleshooting</i>	28-29



Safety Alert Symbol

THIS SAFETY SYMBOL is used to call your attention to instructions that concern your personal safety. It means: ATTENTION! BE AWARE! THIS IS AN IMPORTANT SAFETY INSTRUCTION!

Read, understand, and follow these safety instructions. Failure to follow these safety instructions may result in injury or death.

DANGER

Immediate hazards which, if not avoided, WILL result in serious personal injury or death.

WARNING

Hazards or unsafe practices which, if not avoided, COULD result in serious personal injury or death.

CAUTION

Hazards or unsafe practices which, if not avoided, COULD result in minor personal injury or property damage.

RETAIN SAFETY INFORMATION



This manual should be read and understood by all personnel who assemble, operate or service this hydraulic bender. Failure to understand how to safely assemble, operate and service this unit could result in injury or death. This unit should only be assembled, operated and serviced by qualified personnel.



IMPORTANT SAFETY INFORMATION

- ⚠ DANGER** NEVER operate the bender in an explosive atmosphere.
- ⚠ WARNING** NEVER operate the bender in wet or damp locations. DO NOT expose the bender to rain.
- ⚠ WARNING** ALWAYS disconnect the bender from the hydraulic pump before servicing and when not in use.
- ⚠ WARNING** ALWAYS inspect the bender before operating. Replace any damaged, missing or worn parts. Check for alignment of moving parts, binding of moving parts, breakage of parts and any other conditions that may effect its operation.
- ⚠ WARNING** NEVER alter this equipment. Doing so will void the warranty.
- ⚠ WARNING** ALWAYS keep hands and feet away from pinch points such as bending shoes, follow bars, saddles, conduit and other moving parts.
- ⚠ WARNING** ALWAYS use appropriate bending shoe, follow bar and saddle for the size conduit to be bent.
- ⚠ WARNING** ALWAYS keep conduit under control when unloading.
- ⚠ WARNING** ALWAYS keep the path of the bending conduit clear of obstructions. Make sure all obstacles are clear of the bending path BEFORE you bend the conduit.
- ⚠ WARNING** ALWAYS wear approved safety glasses when the bender is in operation.
- ⚠ WARNING** ALWAYS wear proper apparel. Do not wear loose clothing, gloves, neckties, rings, bracelets, or other jewelry which may get caught in moving parts. Non-slip footwear is recommended. Wear protective hair covering to contain long hair.
- ⚠ WARNING** NEVER stand in direct line with the hydraulic cylinder while operating or servicing the bender. Some parts of the cylinder are under high pressure and can be propelled with considerable force.



IMPORTANT SAFETY INFORMATION — *continued*

- ⚠ WARNING** NEVER stand in direct line with the follow bar while operating the bender. The follow bar is under high pressure during use and can be propelled with considerable force.
- ⚠ WARNING** ALWAYS read and understand the safety and operating instructions supplied with your hydraulic pump.
- ⚠ WARNING** ALWAYS keep children away. All visitors should remain a safe distance from work area.
- ⚠ CAUTION** The bender and some accessories exceed 50 lbs. and will require more than one person to lift, transport and assemble.
- ⚠ CAUTION** Only use the bender for its intended purpose as specified in this manual.
- ⚠ CAUTION** ALWAYS maintain bender with care. Keep bender clean for best and safest performance.
- ⚠ CAUTION** CHECK all hose connections prior to use and ensure they are properly connected. Improper connections may not allow the hydraulic cylinder to retract after the bend is complete.

SPECIFICATIONS – 254 CONDUIT BENDER

Model Number	254
Storage Box Size	60"W x 24"D x 28 1/2"H
Weight (w/Storage Box)	993 lbs.
Bending Capacity	2 1/2", 3", 3 1/2", 4" EMT, IMC and Rigid conduit

MAJOR COMPONENTS – BENDER

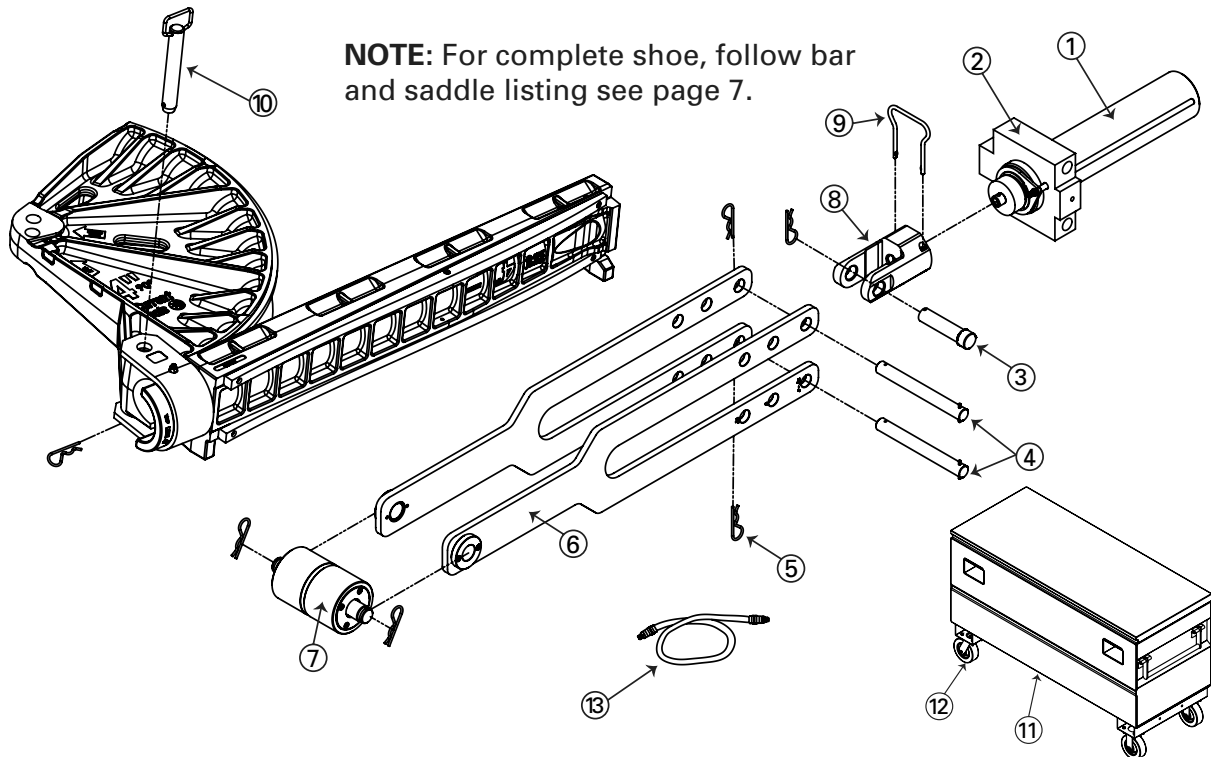

MAJOR COMPONENTS – PARTS LIST

ITEM	CATALOG	DESCRIPTION	QTY.
1	254-100	HYDRAULIC CYLINDER (INCLUDES ITEM #2)	1
2	254-101	CYLINDER MOUNTING BLOCK WITH SET SCREW	1
3	254-107	CLEVIS PIN	1
4	254-148	CYLINDER BLOCK PIN	2
5	254-006	SPRING CLIP	6
6	254-104	FRAME SIDE ASSEMBLY	2
7	254-151	ROLLER ASSEMBLY	1
8	254-103	CLEVIS	1
9	254-108	CLEVIS RETAINING CLIP	1
10	254-149	SADDLE PIN	1
11	105	STORAGE BOX	1
12	506	CASTER SET – 2 RIGID, 2 SWIVEL	1
13	291	HYDRAULIC HOSE	1

MAJOR COMPONENTS – SHOE GROUPS

2 1/2"

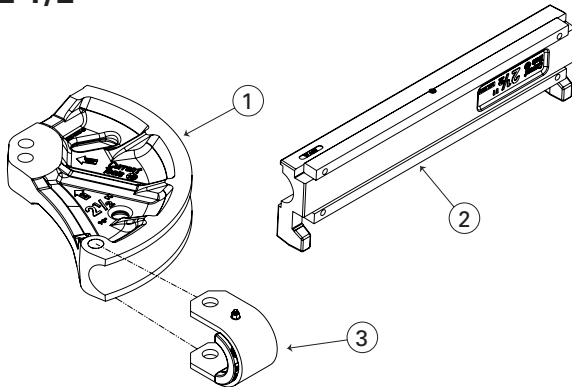

254-110 – For bending 2 1/2" EMT, IMC and Rigid conduit

Key	Catalog#	Description
1	254-111	Bending Shoe – 2 1/2"
2	254-112	Follow Bar – 2 1/2"
3	254-114	Saddle – 2 1/2"

3"

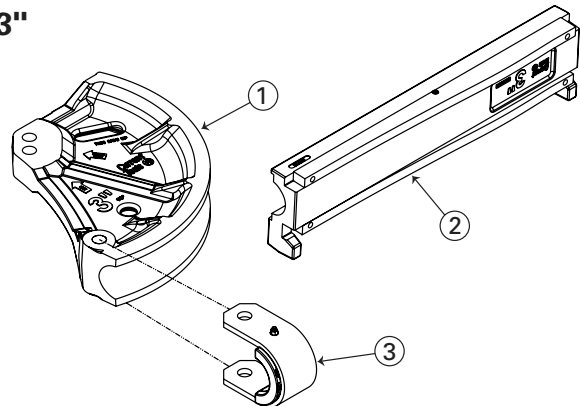

254-117 — For bending 3" EMT, IMC and Rigid conduit

Key	Catalog#	Description
1	254-118	Bending Shoe – 3"
2	254-119	Follow Bar – 3"
3	254-121	Saddle – 3"

3 1/2"

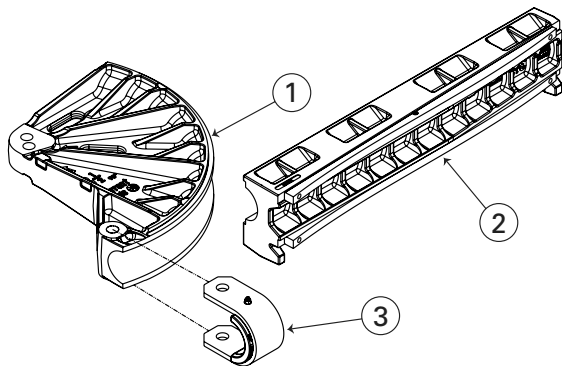

254-124 – For bending 3 1/2" EMT, IMC and Rigid conduit

Key	Catalog#	Description
1	254-125	Bending Shoe – 3 1/2"
2	254-126	Follow Bar – 3 1/2"
3	254-128	Saddle – 3 1/2"

4"

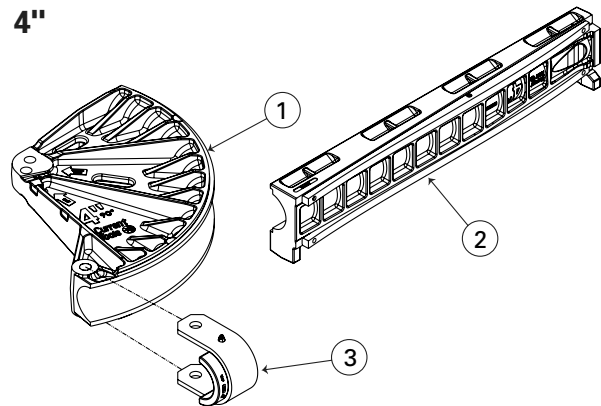

254-131 – For bending 4" EMT, IMC and Rigid conduit

Key	Catalog	Description
1	254-132	Bending Shoe – 4"
2	254-133	Follow Bar – 4"
3	254-135	Saddle – 4"

CONDUIT CENTERLINE BENDING RADII

Size	2 1/2"	3"	3 1/2"	4"
EMT	13 1/2"	16 1/8"	18 5/8"	21"
IMC	13 1/2"	16 1/8"	18 5/8"	21"
RIGID	13 1/2"	16 1/8"	18 5/8"	21"



ASSEMBLY & OPERATING INSTRUCTIONS – 254 CONDUIT BENDER

FOR OPERATING ON THE FLOOR

1. Locate the two frame sides, roller assembly and two spring clips.

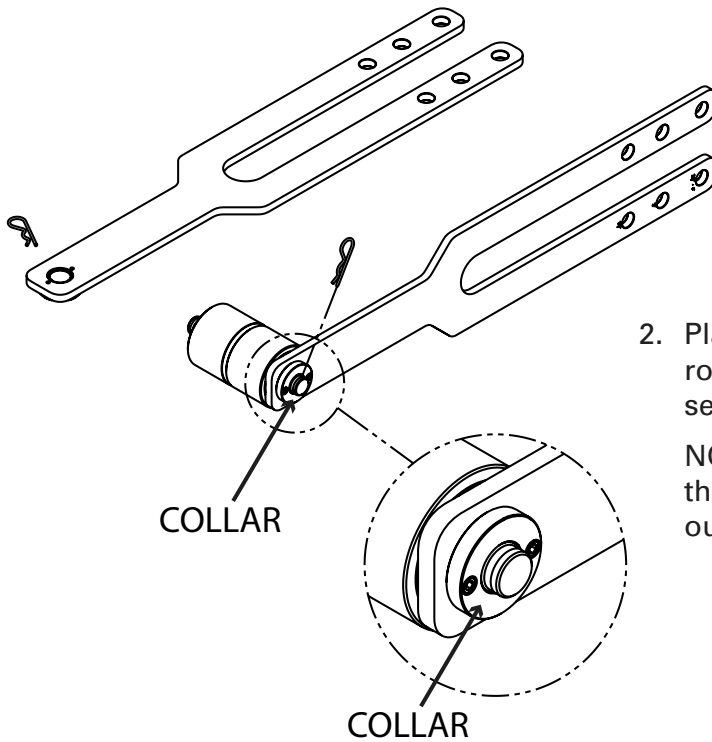
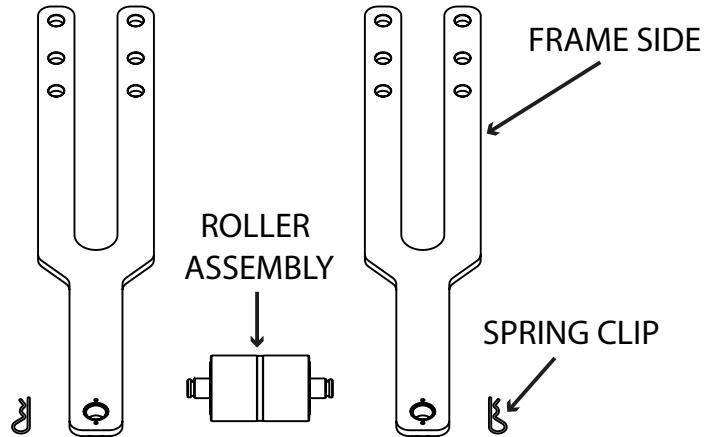

2. Place one frame side onto the roller assembly as shown and secure with a spring clip.

NOTE: The collar in the end of the frame side must be facing outward.

3. Place the second frame side onto the roller assembly and secure with a spring clip.

NOTE: The collar in the end of the frame side must be facing outward.

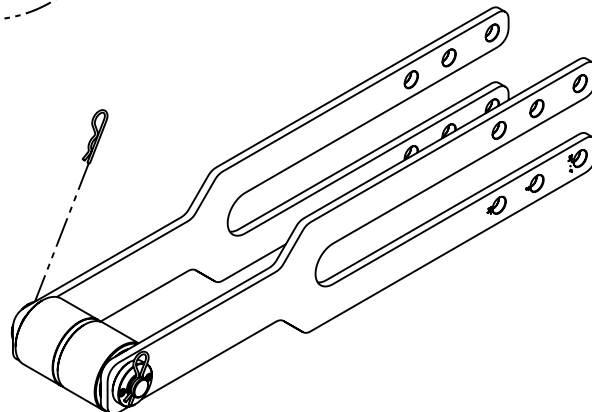

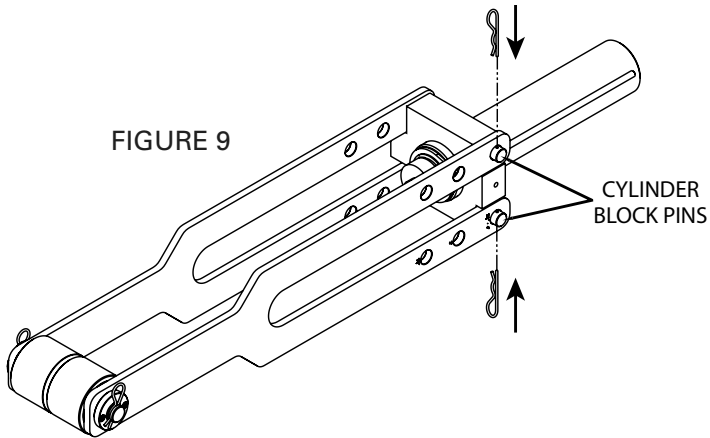

FIGURE 9

- Place the hydraulic cylinder with the cylinder mounting block between the frame sides as shown in Figure 9. Insert the two cylinder block pins into the appropriate frame side holes for the size of conduit to be bent and secure each with a spring clip.

NOTE: The hydraulic cylinder with mounting block in Figure 9 is shown pinned in the position for bending 4" conduit. The frame side holes are marked to indicate where to pin the mounting block for each size.

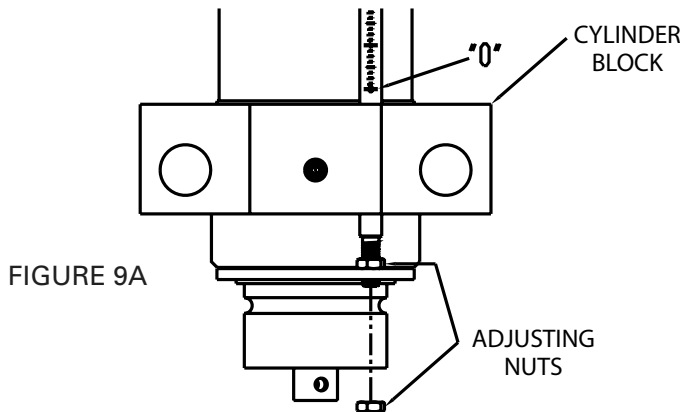

FIGURE 9A

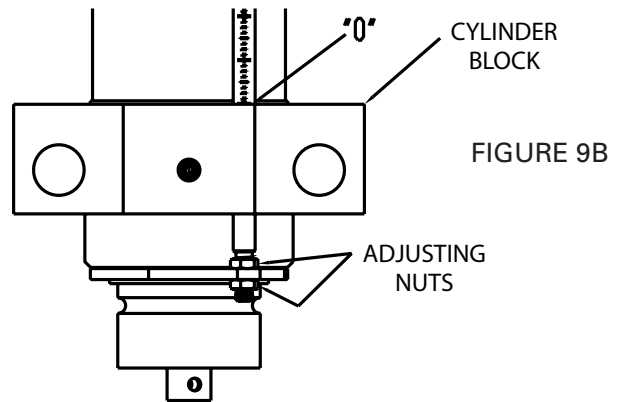

FIGURE 9B

- Adjust gauge rod such that gauge reads zero when the cylinder is fully retracted.

NOTE: To adjust gauge rod, loosen gauge rod adjusting nuts (see Figure 9A) and adjust rod such that zero (Ø) is flush with the top of the cylinder block (see Figure 9B).

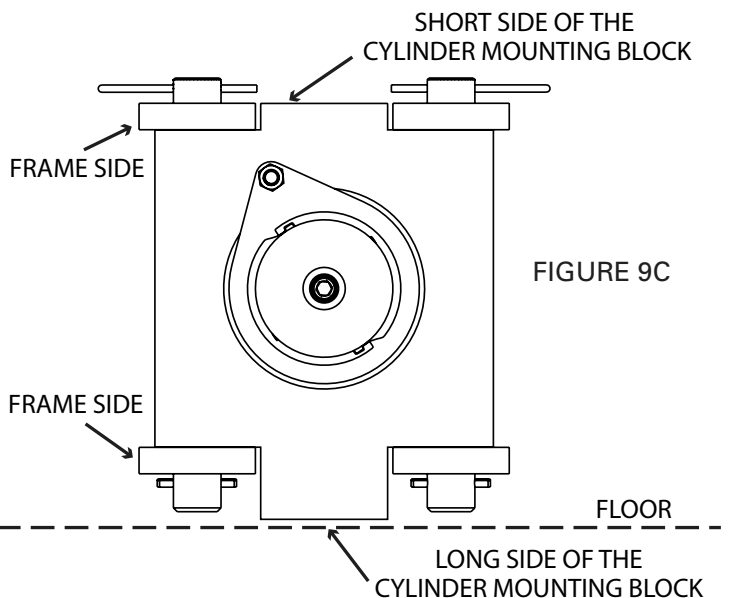

FIGURE 9C

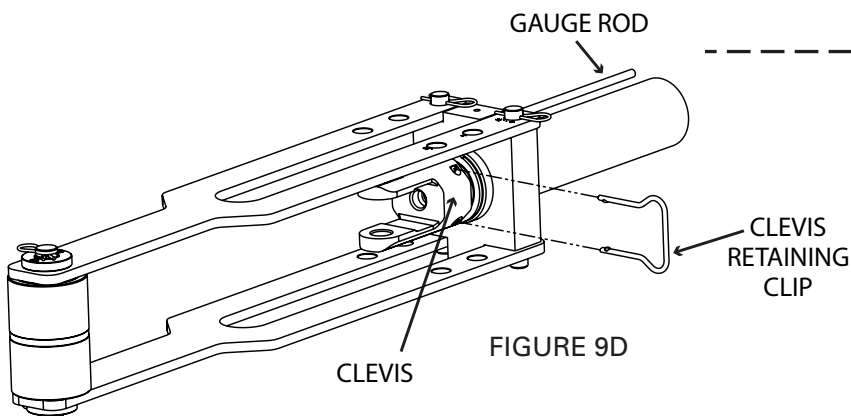

FIGURE 9D

- Rotate the frame and hydraulic cylinder so the long side of the cylinder mounting block is resting on the floor (See Figure 9C). Then place the clevis onto the end of the hydraulic cylinder and secure with the clevis retaining clip (see Figure 9D).

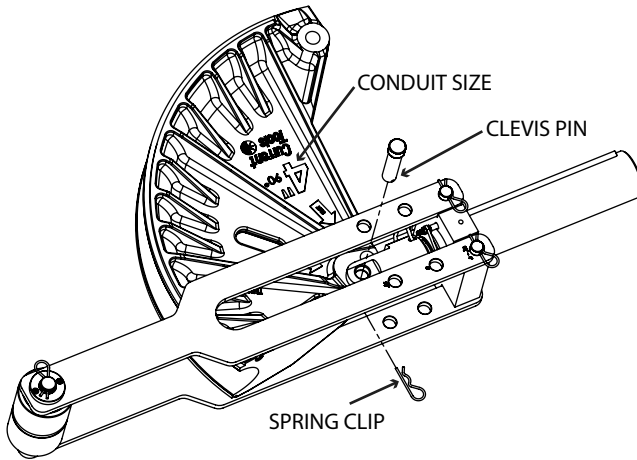

FIGURE 10

7. Select the shoe for the size conduit you will be bending. Place the shoe between the frame sides as shown, with the conduit size facing upward. Align the clevis with the correct hole on the shoe for the type conduit you will be bending (Rigid/IMC or EMT). Insert the clevis pin and secure with a spring clip (see Figure 10).

NOTE: Arrows on the bending shoe indicate the correct hole for bending either Rigid/IMC or EMT conduit (see Figure 10A).

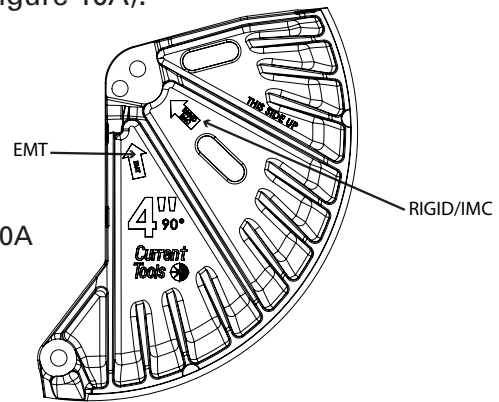

FIGURE 10A

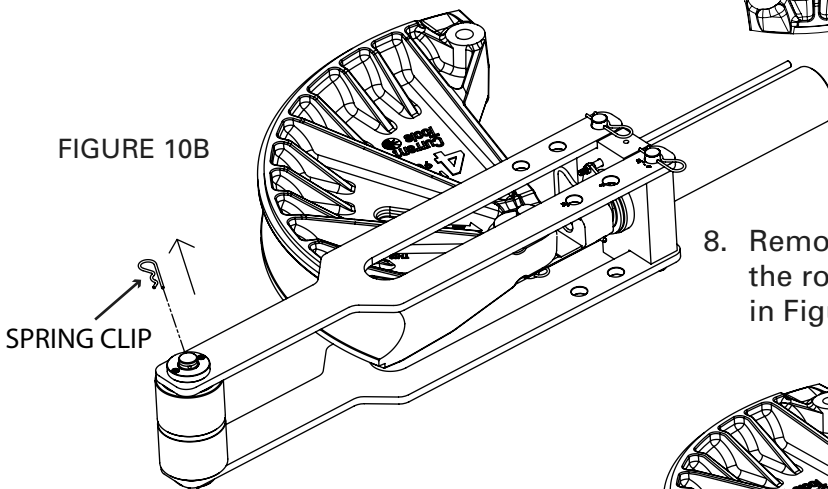

FIGURE 10B

8. Remove the spring clip from the roller assembly as shown in Figure 10B.

9. Raise the frame side and place the correct follow bar for the size conduit to be bent between the frame sides as shown in Figure 10C. The "START" mark on the follow bar should be just past the roller assembly and face upward.

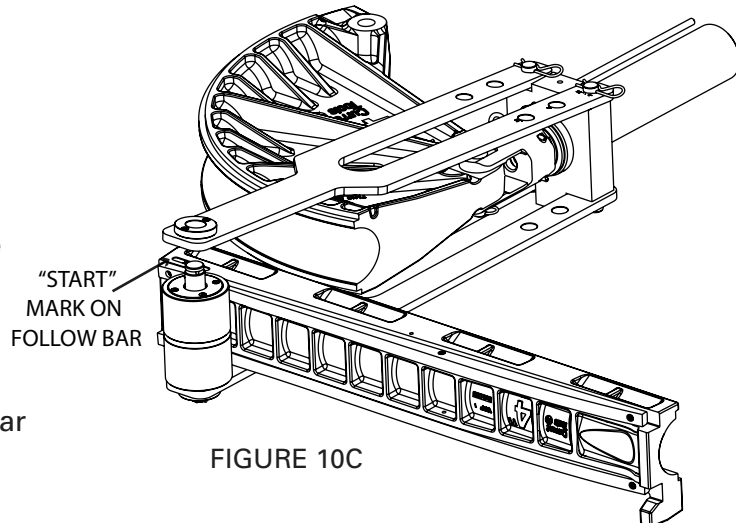
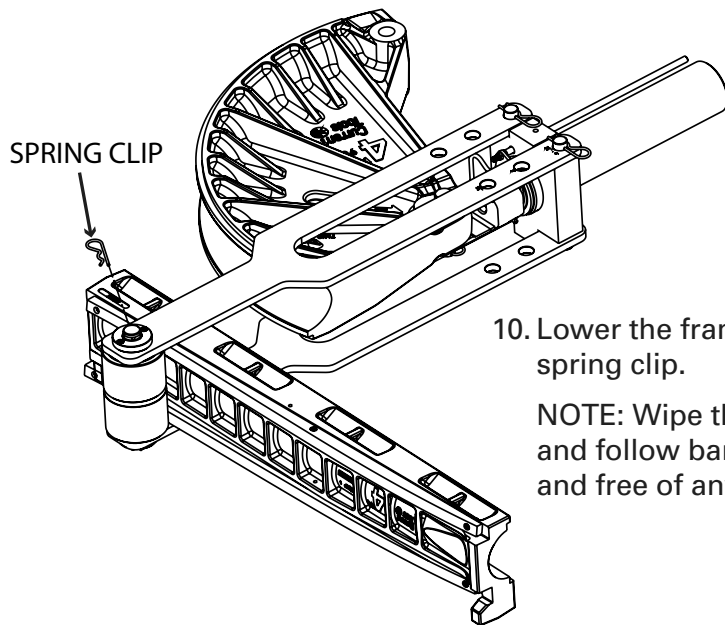
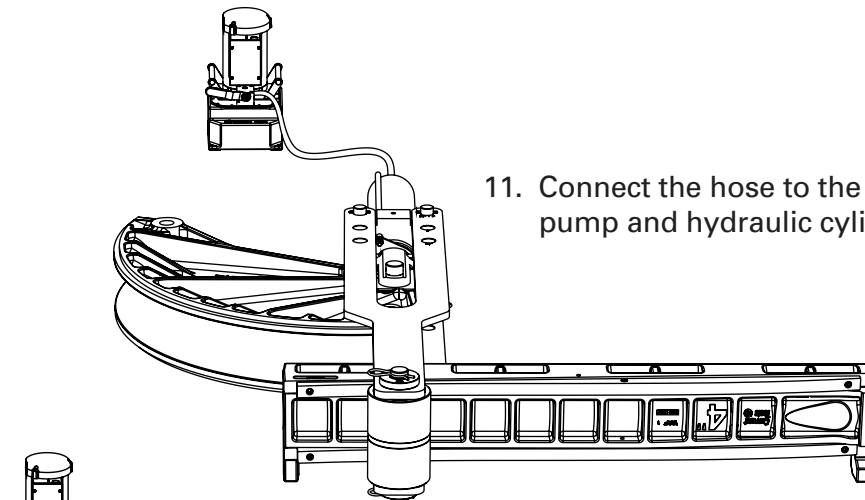

FIGURE 10C



10. Lower the frame side and secure with the spring clip.

NOTE: Wipe the groove of both the shoe and follow bar and ensure they are clean and free of any debris.



11. Connect the hose to the pump and hydraulic cylinder.

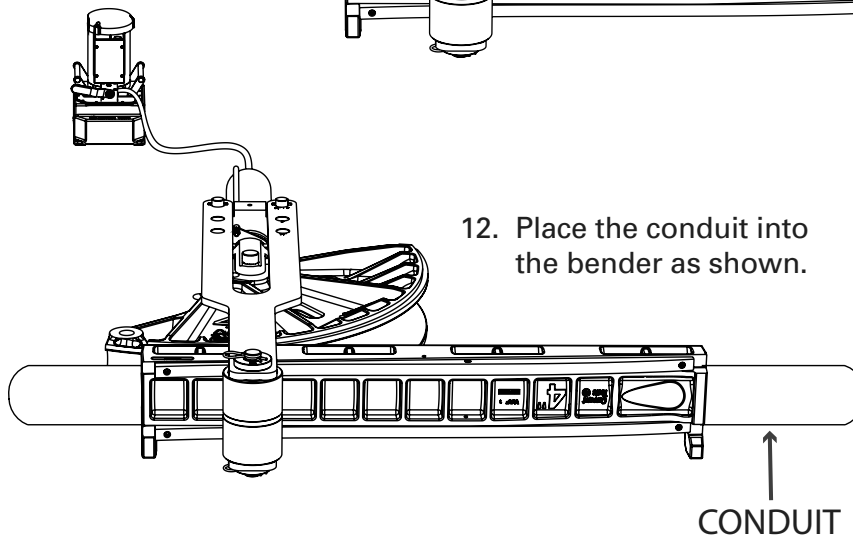

12. Place the conduit into the bender as shown.

CONDUIT

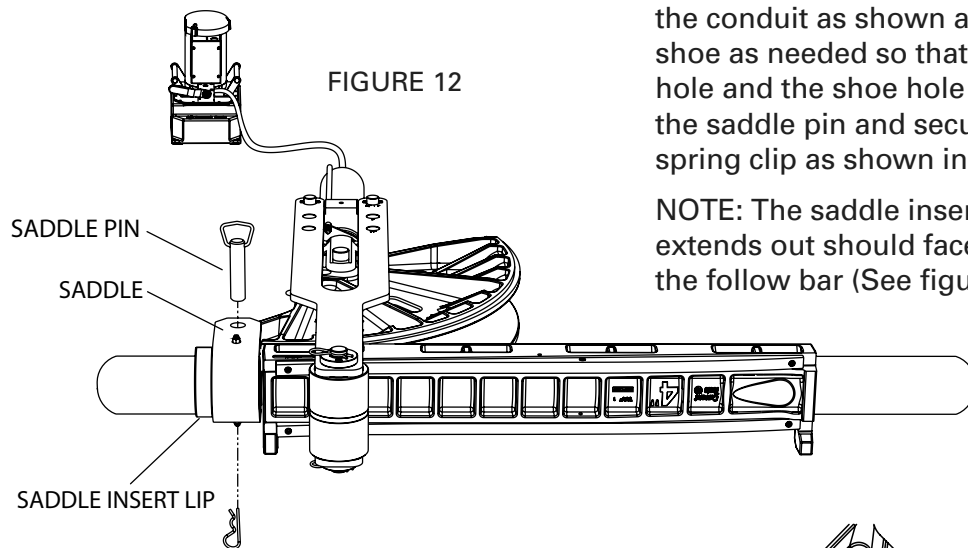

FIGURE 12

13. Place the correct size saddle around the conduit as shown and rotate the shoe as needed so that the saddle hole and the shoe hole align. Insert the saddle pin and secure with the spring clip as shown in Figure 12.

NOTE: The saddle insert lip that extends out should face away from the follow bar (See figure 12A).

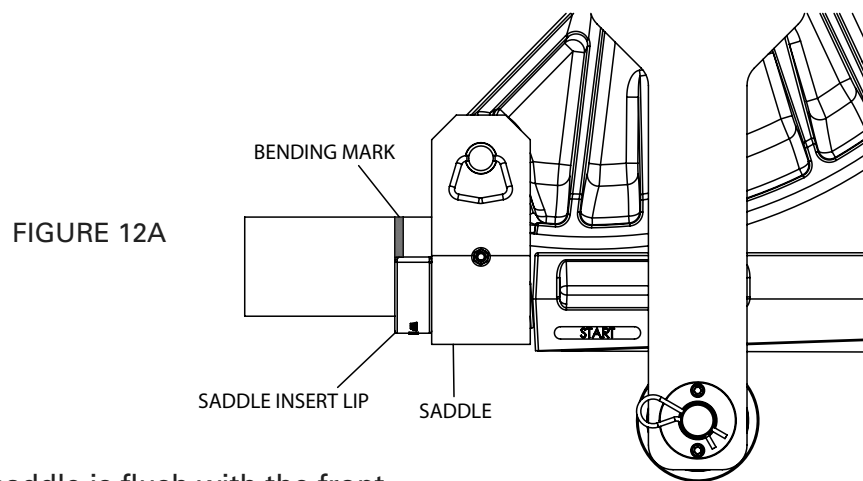

FIGURE 12A

14. Make sure the saddle is flush with the front of the follow bar. The bending mark on the conduit should be aligned with the front edge of the saddle insert lip (see figure 12A). Rotate the pump valve lever to the closed position and activate the hydraulic pump until the shoe contacts the conduit and the saddle and follow bar are snug.
15. **DO NOT BEGIN BEND.** Before bending — To determine the amount of cylinder travel for the size, type and degree of bend, refer to the cylinder travel and bender calibration information on page 16.
16. Activate the hydraulic pump to begin the bend. (See figure 12B).

NOTE: **DO NOT** over extend the hydraulic cylinder during operation. This will allow hydraulic fluid to escape the cylinder and may cause a hazardous condition.

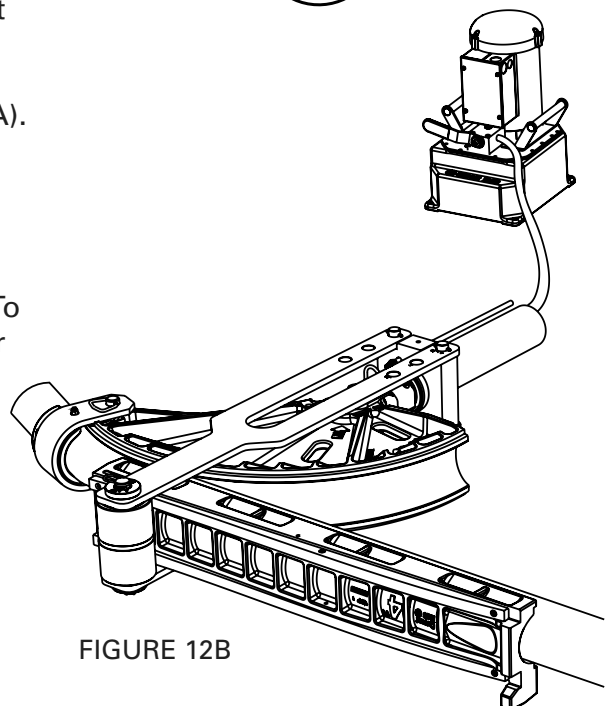
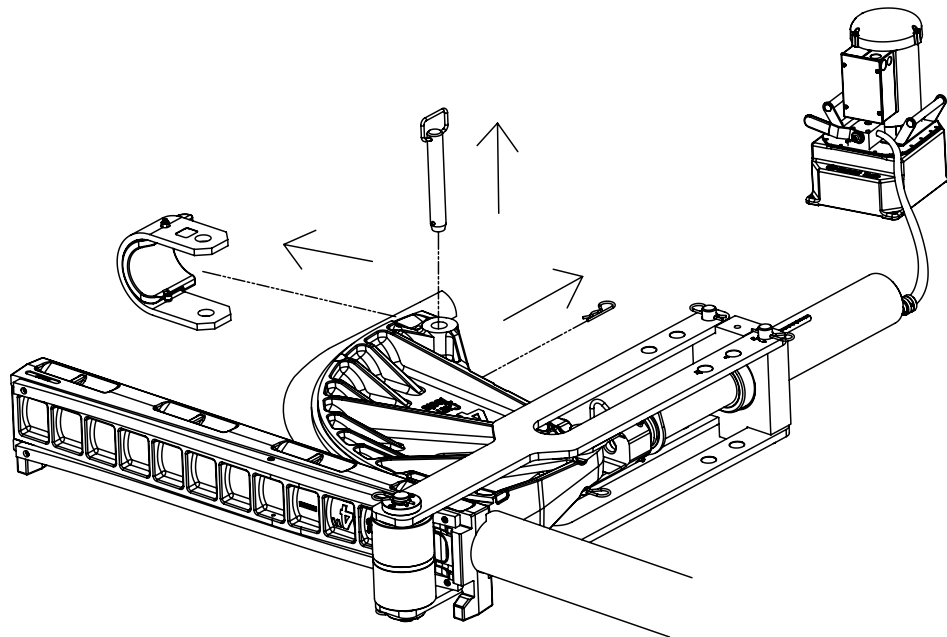
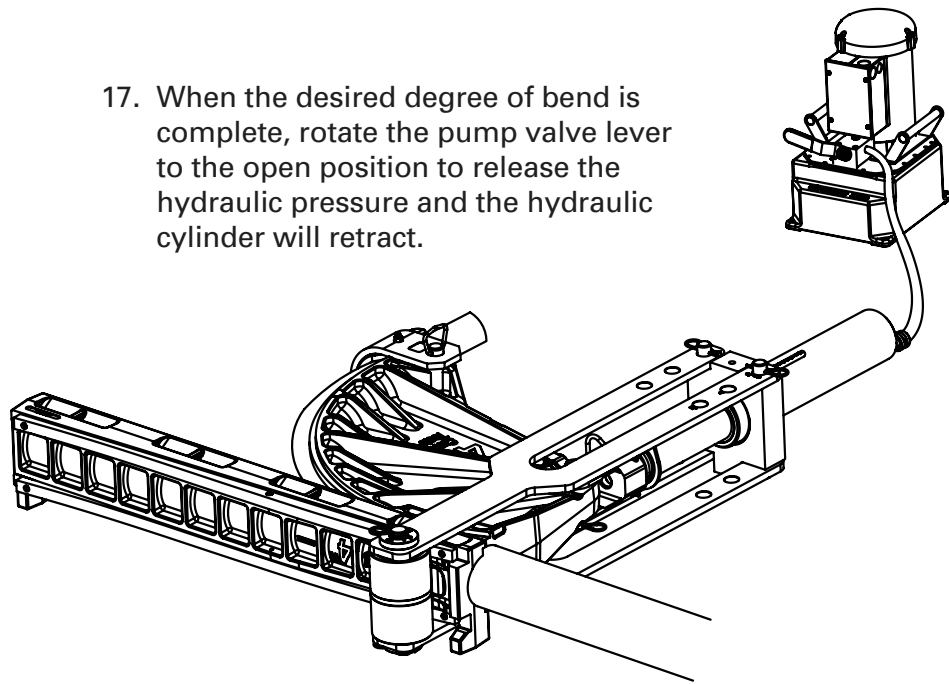

FIGURE 12B



17. When the desired degree of bend is complete, rotate the pump valve lever to the open position to release the hydraulic pressure and the hydraulic cylinder will retract.



18. Once the hydraulic pressure is released and the hydraulic cylinder has retracted, remove the saddle pin spring clip. Remove the saddle pin and saddle. Next, remove the bent conduit from the bending set-up.

90° BENDING INFORMATION AND CHARTS

NOTE: Current Tools Model #254 bending shoes and follow bars are designed to make up to 90° bends with one extension of the hydraulic cylinder (one shot bends). The Greenlee® Model #881CT CamTrack®* hydraulic bender shoes and follow bars will fit the Current Tools Model #254 Hydraulic Bender.

To locate bending marks for a 90° bend with a desired stub length:

1. Determine desired stub length

NOTE: Check corresponding chart on page 15 for the type and size conduit being bent and ensure the desired stub length is greater than the “minimum stub length” shown in the chart.

2. From the end of the conduit, measure and mark the desired stub length on the conduit (stub length mark). See figure 14B.
3. Subtract “Deduct Length” from the stub length mark and make a second mark (Bending Mark). See figure 14B.

NOTE: Check corresponding chart on page 15 for the deduct length of the type and size conduit being bent

NOTE: Check corresponding chart for the type and size conduit being bent and ensure the “Bending Mark” is equal to or greater than the “Minimum Distance from End of Conduit.”

4. Align the bending mark with the lip of the saddle as shown in figure 14C. Proceed with the bend as shown in the Assembly and Operating section.

FIGURE 14A

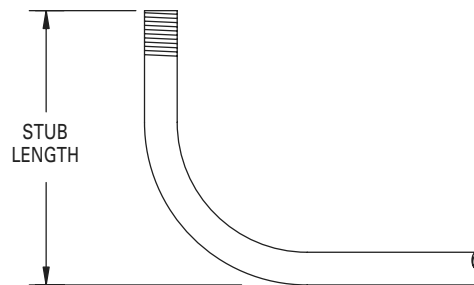

FIGURE 14B

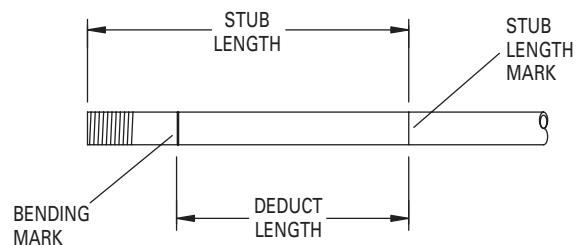
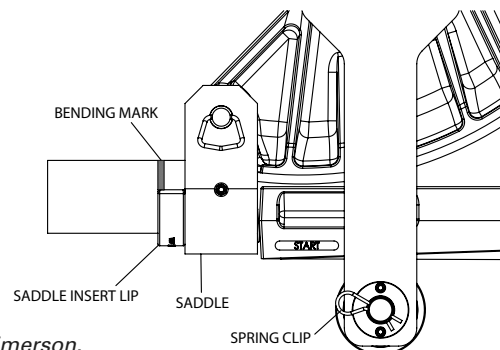

FIGURE 14C



* Greenlee® and CamTrack® are registered trademarks of Emerson.

**Chart A – RIGID Conduit/Schedule 40 Pipe**

Conduit Size	Deduct Length	Minimum Stub Length	Minimum Distance from End of Conduit
2 1/2"	21 1/2"	24"	2 1/2"
3"	24 1/4"	26 3/4"	2 1/2"
3 1/2"	28 1/4"	30 3/4"	2 1/2"
4"	32 1/2"	35"	2 1/2"

Chart B – EMT Conduit

Conduit Size	Deduct Length	Minimum Stub Length	Minimum Distance from End of Conduit
2 1/2"	21 1/2"	24"	2 1/2"
3"	24"	27"	3"
3 1/2"	27 3/4"	31 1/4"	3 1/2"
4"	32 1/4"	36 1/4"	4"

Chart C – IMC Conduit

Conduit Size	Deduct Length	Minimum Stub Length	Minimum Distance from End of Conduit
2 1/2"	21 1/2"	24"	2 1/2"
3"	24 1/4"	26 3/4"	2 1/2"
3 1/2"	28 1/4"	30 3/4"	2 1/2"
4"	32 1/2"	35"	2 1/2"



CYLINDER TRAVEL AND BENDER CALIBRATION

NOTE: Read the gauge rod at the edge of the cylinder mounting block. Gauge rod should read zero (Ø) when cylinder is fully retracted.

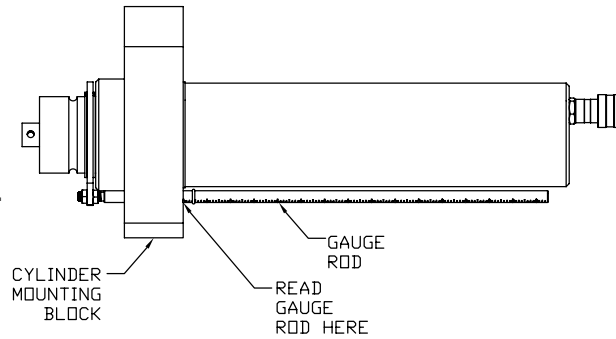

1. The bender must be calibrated prior to bending. To calibrate, rotate the pump valve lever to the closed position and activate the pump to advance the hydraulic cylinder until the shoe, conduit and follow bar tighten up. Stop the pump and DO NOT advance the cylinder far enough to start a bend.
2. Read the measurement on the gauge rod and compare that with the 0° (tight) number for the appropriate conduit type and size on the charts below. If there is a difference in these two numbers, that difference must be included in the cylinder travel measurements for that type and size of conduit.

CYLINDER TRAVEL (APPROXIMATE) EMT CONDUIT

DEGREE OF BEND	2 1/2" (90°)	3" (90°)	3 1/2" (90°)	4" (90°)
0° (tight)	4 3/16	3 7/8	2 7/8	2 3/16
10°	4 7/8	4 7/8	3 15/16	3 3/8
15°	5 3/16	5 3/16	4 3/8	3 3/4
30°	6 1/8	6 1/4	5 7/16	4 7/8
45°	7 1/16	7 1/8	6 1/2	6 1/16
60°	8	8 3/16	7 5/8	7 3/16
90°	9 1/2	10 3/8	9 7/8	9 1/2

IMC CONDUIT

DEGREE OF BEND	2 1/2" (90°)	3" (90°)	3 1/2" (90°)	4" (90°)
0° (tight)	2 7/8	2 1/4	1 5/8	1 1/16
10°	4	3 9/16	2 15/16	2 7/16
15°	4 3/8	4 1/16	3 7/16	3
30°	5 3/16	5 5/8	4 7/8	4 5/8
45°	7 5/16	7 3/16	6 3/8	6 1/4
60°	8 3/4	8 9/16	8 1/16	8
90°	11 3/16	11 13/16	11 1/4	11 1/4

RIGID CONDUIT

DEGREE OF BEND	2 1/2" (90°)	3" (90°)	3 1/2" (90°)	4" (90°)
0° (tight)	2 7/8	2 5/16	1 7/16	1
10°	3 13/16	3 9/16	2 13/16	2 3/8
15°	4 5/16	4	3 5/16	2 15/16
30°	5 11/16	5 7/16	4 13/16	4 5/8
45°	7 1/8	7 1/16	6 3/8	6 3/16
60°	8 9/16	8 11/16	7 13/16	7 13/16
90°	11 1/16	11 3/4	10 7/8	11 1/8



COMMON BENDS LAYOUT INFORMATION

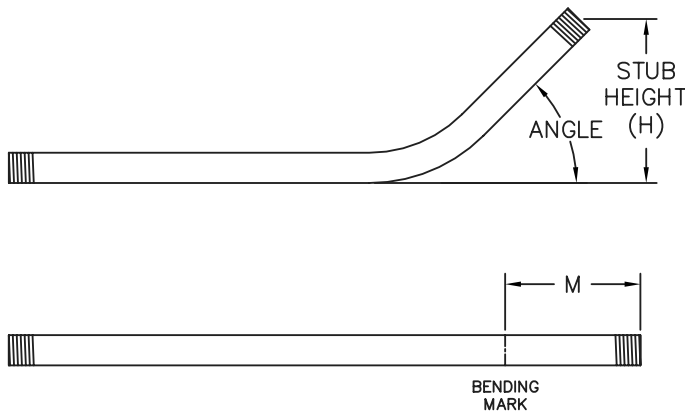

FIGURE 17A

STUBS

1. Determine the desired stub height (H) and angle for the bend (See figure 17A).
2. Locate the chart (see pgs. 20 - 23) that corresponds to the size and type conduit you are going to bend.
3. Using the desired angle, locate the "M" value that corresponds to the desired height of bend.
4. Make a mark the distance "M" from the end of the conduit. This is your Bending Mark.
5. You may now proceed with the bend.

U-BENDS

1. Determine the desired height (H) and length (L) for the U-bend (See figure 17B).
2. Locate the chart (see pgs. 20 - 23) that corresponds to the size and type conduit you are going to bend.
3. Under the row corresponding to 90°, locate the "M" value corresponding to the length (L) of the U-bend.

NOTE: For a U-bend, the "L" value is labeled "HEIGHT" in the charts

4. Make a mark the distance "M" from the end of the conduit. This is your first bending mark (Mark 1).
5. Under the row corresponding to 90° locate the "C" value corresponding to the height (H) of the U-bend.
6. Make a mark the distance "C" from Mark 1. This is your second bending mark (Mark 2).
7. You may now proceed with the bend.

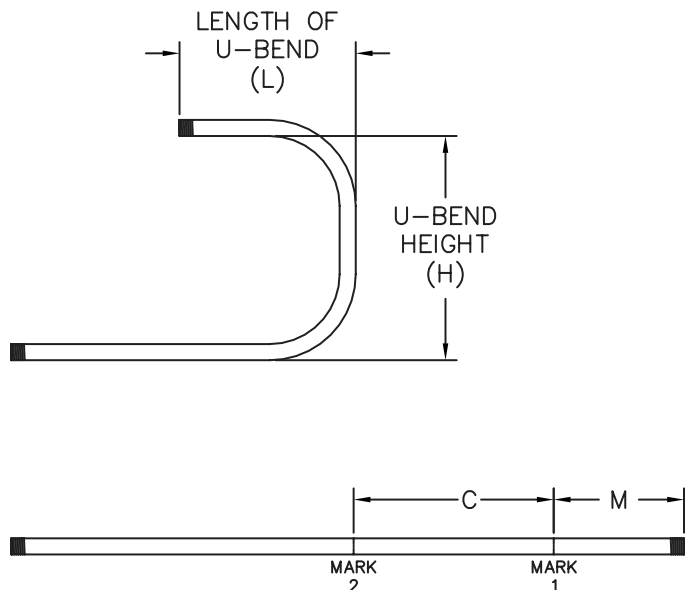

FIGURE 17B



COMMON BENDS LAYOUT INFORMATION — *continued*

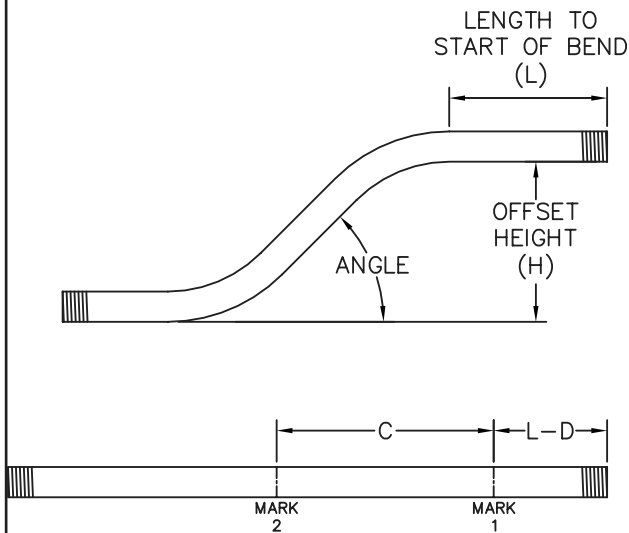

FIGURE 18A

OFFSETS: WORKING PAST AN OBSTACLE

1. Determine the desired length (L), height (H) and angle for the offset (See figure 18A).
2. Locate the chart (see pgs. 20 - 23) that corresponds to the size and type conduit you are going to bend.
3. In the upper left corner of the chart find the "D" value for the size and type conduit you are going to bend. Deduct this value from the desired length (L) and make a mark this distance from the end of the conduit. This is your first bending mark (Mark 1).
4. Using the desired angle, locate the "C" value that corresponds to the desired height (H). Make a mark the distance "C" from Mark 1. This is your second bending mark (Mark 2).
5. You may now proceed with the bend.

NOTE: For offsets of heights other than those listed, refer to "Calculating "C" Values for Offsets Past an Obstacle" on pg. 24.

OFFSETS: WORKING TOWARDS AN OBSTACLE

1. Determine the length to the end of bends (L), offset height (H) and angle for the offset (See figure 18B).
2. Locate the chart (see pgs. 20 - 23) that corresponds to the size and type conduit you are going to bend.
3. Using the desired angle, locate the "E" value that corresponds to the desired height (H). Deduct this value from the length (L) and make a mark this distance from the end of the conduit. This is your first bending mark (Mark 1).
4. Next, locate the "C" value that corresponds to the desired height (H). Make a mark the distance "C" from Mark 1. This is your second bending mark (Mark 2).
5. You may now proceed with the bend.

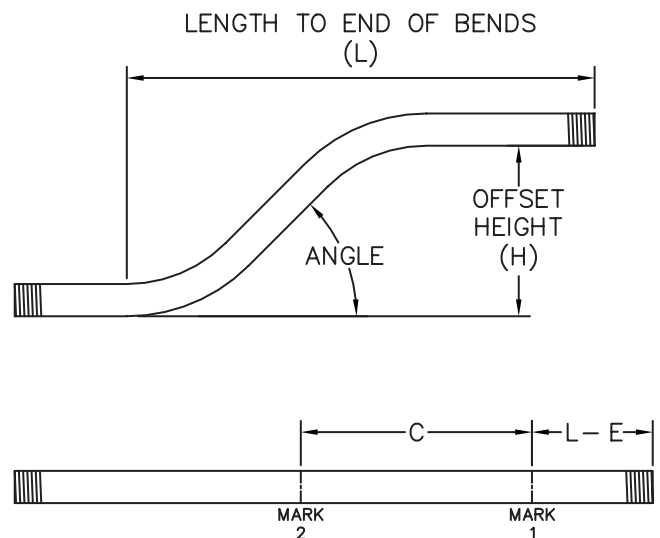

FIGURE 18B

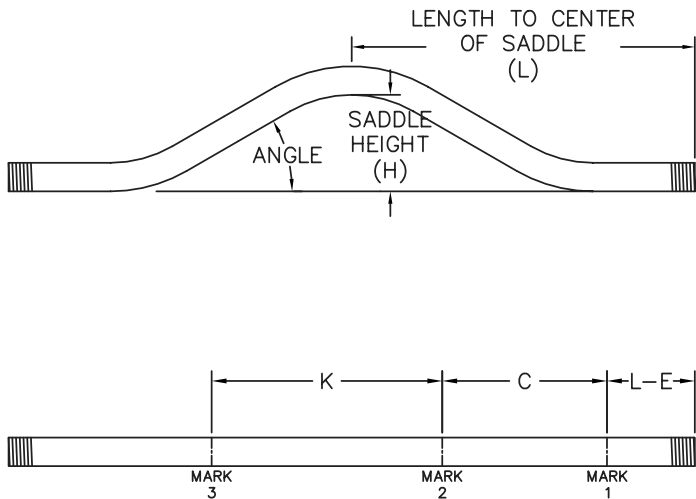

FIGURE 19A

THREE-POINT SADDLES

1. Determine the length to the center of the saddle (L), saddle height (H) and angle for the saddle (See Figure 19A)
2. Locate the chart (see pgs. 20 – 23) that corresponds to the size and type conduit you are going to bend.
3. Using the desired angle, locate the “E” value that corresponds to the desired height (H). Deduct this value from the length (L) and make a mark this distance from the end of the conduit. This is your first bending mark (Mark 1).
4. Next, locate the “C” value that corresponds to the desired height of bend. Make a mark the distance “C” from Mark 1. This is your second bending mark (Mark 2).
5. Lastly, locate the “K” value that corresponds to the desired height (H). Make a mark the distance “K” from Mark 2. This is your third bending mark (Mark 3).
6. You may now proceed with the bend.

FOUR-POINT SADDLES

1. Determine the length to the start of the flat section (L), the length of the flat section (F), saddle height (H), and angle for the saddle (See Figure 19B).
2. Locate the chart (See pgs. 20-23) that corresponds to the size and type conduit you are going to bend.
3. Using the desired angle, locate the “E” value that corresponds to the desired height (H). Deduct this value from the length (L) and make a mark this distance from the end of the conduit. This is your first bending mark (Mark 1).
4. Next locate the “K” value that corresponds to the desired height (H). Add this value to the length of the flat section (F) and make a mark this distance from Mark 1. This will be your third bending mark (Mark 3).
5. Lastly, locate the “C” value that corresponds to the desired height (H). Make one mark this distance from Mark 1. This will be your second bending mark (Mark 2). Then make another mark the distance “C” from Mark 3 (see Figure 19B). This is your fourth bending mark (Mark 4).
6. You may now proceed with the bend.

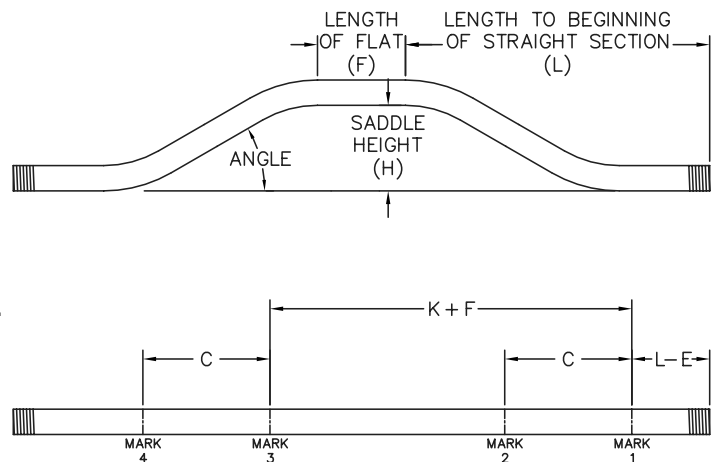

FIGURE 19B



VALUES FOR LAYOUT OF COMMON BENDS

Chart D – 2 1/2" EMT

D = 6 1/8		HEIGHT									
ANGLE	DIM	10	12	16	20	24	30	36	42	48	60
15°	M	25 1/8	32 13/16	48 5/16	63 3/4	79 3/16	102 3/8	125 9/16	148 3/4	171 15/16	218 5/16
	C	38 5/8	46 5/16	61 13/16	77 1/4	92 11/16	115 7/8	139 1/16	162 1/4	185 7/16	231 13/16
	K	42 1/4	50	65 7/16	80 7/8	96 3/8	119 1/2	142 11/16	165 7/8	189 1/16	235 7/16
	E	47 1/8	54 5/8	69 1/2	84 7/16	99 3/8	121 3/4	144 3/16	166 9/16	188 15/16	233 3/4
30°	M	7 1/4	11 1/4	19 1/4	27 1/4	35 1/4	47 1/4	59 1/4	71 1/4	83 1/4	107 1/4
	C	19 13/16	23 13/16	31 13/16	39 13/16	47 13/16	59 13/16	71 13/16	83 13/16	95 13/16	119 13/16
	K	27 1/8	31 1/8	39 1/8	47 1/8	55 1/8	67 1/8	79 1/8	91 1/8	103 1/8	127 1/8
	E	30 15/16	34 3/8	41 5/16	48 1/4	55 3/16	65 9/16	75 15/16	86 3/8	96 3/4	117 1/2
45°	M		3	8 11/16	14 3/8	20	28 1/2	37	45 7/16	53 15/16	70 15/16
	C			22	27 11/16	33 5/16	41 13/16	50 5/16	58 13/16	67 5/16	84 1/4
	K			32 15/16	38 5/8	44 1/4	52 3/4	61 1/4	69 11/16	78 3/16	95 3/16
	E			33 11/16	37 11/16	41 11/16	47 11/16	53 11/16	59 11/16	65 11/16	77 11/16
60°	M			2 5/8	7 1/4	11 7/8	18 13/16	25 3/4	32 11/16	39 9/16	53 7/16
	C				21 5/8	26 3/16	33 1/8	40 1/16	47	53 15/16	67 13/16
	K				36 1/8	40 3/4	47 11/16	54 5/8	61 9/16	68 1/2	82 3/8
	E				33 3/4	36 1/16	39 1/2	43	46 7/16	49 15/16	56 13/16
90°	M					2 1/2	8 1/2	14 1/2	20 1/2	26 1/2	38 1/2
	C							30 1/16	36 1/16	42 1/16	54 1/16
	K							51 7/8	57 7/8	63 7/8	75 7/8
	E							33 15/16	33 15/16	33 15/16	33 15/16

Chart E – 2 1/2" RIGID/IMC

D = 6 1/8		HEIGHT									
ANGLE	DIM	10	12	16	20	24	30	36	42	48	60
15°	M	25 1/8	32 13/16	48 5/16	63 3/4	79 3/16	102 3/8	125 9/16	148 3/4	171 15/16	218 5/16
	C	38 5/8	46 5/16	61 13/16	77 1/4	92 11/16	115 7/8	139 1/16	162 1/4	185 7/16	231 13/16
	K	42 1/4	50	65 7/16	80 7/8	96 3/8	119 1/2	142 11/16	165 7/8	189 1/16	235 7/16
	E	47 1/8	54 5/8	69 1/2	84 7/16	99 3/8	121 3/4	144 3/16	166 9/16	188 15/16	233 3/4
30°	M	7 1/4	11 1/4	19 1/4	27 1/4	35 1/4	47 1/4	59 1/4	71 1/4	83 1/4	107 1/4
	C	19 13/16	23 13/16	31 13/16	39 13/16	47 13/16	59 13/16	71 13/16	83 13/16	95 13/16	119 13/16
	K	27 1/8	31 1/8	39 1/8	47 1/8	55 1/8	67 1/8	79 1/8	91 1/8	103 1/8	127 1/8
	E	30 15/16	34 3/8	41 5/16	48 1/4	55 3/16	65 9/16	75 15/16	86 3/8	96 3/4	117 1/2
45°	M		3	8 11/16	14 3/8	20	28 1/2	37	45 7/16	53 15/16	70 15/16
	C		16 3/8	22	27 11/16	33 5/16	41 13/16	50 5/16	58 13/16	67 5/16	84 1/4
	K		27 5/16	32 15/16	38 5/8	44 1/4	52 3/4	61 1/4	69 11/16	78 3/16	95 3/16
	E		29 11/16	33 11/16	37 11/16	41 11/16	47 11/16	53 11/16	59 11/16	65 11/16	77 11/16
60°	M			2 5/8	7 1/4	11 7/8	18 13/16	25 3/4	32 11/16	39 9/16	53 7/16
	C				21 5/8	26 3/16	33 1/8	40 1/16	47	53 15/16	67 13/16
	K				36 1/8	40 3/4	47 11/16	54 5/8	61 9/16	68 1/2	82 3/8
	E				33 3/4	36 1/16	39 1/2	43	46 7/16	49 15/16	56 13/16
90°	M					2 1/2	8 1/2	14 1/2	20 1/2	26 1/2	38 1/2
	C							30 1/16	36 1/16	42 1/16	54 1/16
	K							51 7/8	57 7/8	63 7/8	75 7/8
	E							33 15/16	33 15/16	33 15/16	33 15/16



VALUES FOR LAYOUT OF COMMON BENDS

Chart F – 3" EMT

D = 5 3/4		HEIGHT									
ANGLE	DIM	10	12	16	20	24	30	36	42	48	60
15°	M	23 15/16	31 11/16	47 1/8	62 9/16	78	101 3/16	124 3/8	147 9/16	170 3/4	217 1/8
	C	38 5/8	46 5/16	61 13/16	77 1/4	92 11/16	115 7/8	139 1/16	162 1/4	185 7/16	231 13/16
	K	42 15/16	50 5/8	66 1/8	81 9/16	97	120 3/16	143 3/8	166 9/16	189 3/4	236 1/8
	E	47 7/16	54 7/8	69 13/16	84 3/4	99 11/16	122 1/16	144 7/16	166 7/8	189 1/4	234 1/16
30°	M	6 5/16	10 5/16	18 5/16	26 5/16	34 5/16	46 5/16	58 5/16	70 5/16	82 5/16	106 5/16
	C	19 13/16	23 13/16	31 13/16	39 13/16	47 13/16	59 13/16	71 13/16	83 13/16	95 13/16	119 13/16
	K	28 7/16	32 7/16	40 7/16	48 7/16	56 7/16	68 7/16	80 7/16	92 7/16	104 7/16	128 7/16
	E	31 15/16	35 3/8	42 5/16	49 1/4	56 3/16	66 9/16	76 15/16	87 3/8	97 3/4	118 1/2
45°	M			7 9/16	13 3/16	18 7/8	27 3/8	35 13/16	44 5/16	52 13/16	69 13/16
	C			21 15/16	27 9/16	33 1/4	41 11/16	50 3/16	58 11/16	67 3/16	84 1/8
	K			34 7/8	40 1/2	46 3/16	54 11/16	63 1/8	71 5/8	80 1/8	97 1/16
	E			35 7/16	39 7/16	43 7/16	49 7/16	55 7/16	61 7/16	67 7/16	79 7/16
60°	M				5 13/16	10 7/16	17 5/16	24 1/4	31 3/16	38 1/8	52
	C					25 15/16	32 7/8	39 13/16	46 3/4	53 5/8	67 1/2
	K					43 3/16	50 1/8	57 1/16	64	70 15/16	84 3/4
	E					38 5/8	42 1/8	45 9/16	49 1/16	52 1/2	59 7/16
90°	M						6	12	18	24	36
	C								34 15/16	40 15/16	52 15/16
	K								60 13/16	66 13/16	78 13/16
	E								38 3/4	38 3/4	38 3/4

Chart G – 3" RIGID/IMC

D = 6		HEIGHT									
ANGLE	DIM	10	12	16	20	24	30	36	42	48	60
15°	M	23 11/16	31 7/16	46 7/8	62 5/16	77 13/16	101	124 3/16	147 3/8	170 1/2	216 7/8
	C	38 5/8	46 5/16	61 13/16	77 1/4	92 11/16	115 7/8	139 1/16	162 1/4	185 7/16	231 13/16
	K	42 15/16	50 5/8	66 1/8	81 9/16	97	120 3/16	143 3/8	166 9/16	189 3/4	236 1/8
	E	47 11/16	55 1/8	70 1/16	85	99 15/16	122 5/16	144 11/16	167 1/16	189 1/2	234 1/4
30°	M	6 1/16	10 1/16	18 1/16	26 1/16	34 1/16	46 1/16	58 1/16	70 1/16	82 1/16	106 1/16
	C	19 13/16	23 13/16	31 13/16	39 13/16	47 13/16	59 13/16	71 13/16	83 13/16	95 13/16	119 13/16
	K	28 7/16	32 7/16	40 7/16	48 7/16	56 7/16	68 7/16	80 7/16	92 7/16	104 7/16	128 7/16
	E	32 1/8	35 5/8	42 9/16	49 1/2	56 3/8	66 13/16	77 3/16	87 9/16	98	118 3/4
45°	M			7 5/16	13	18 5/8	27 1/8	35 5/8	44 1/8	52 9/16	69 9/16
	C			21 15/16	27 9/16	33 1/4	41 11/16	50 3/16	58 11/16	67 3/16	84 1/8
	K			34 7/8	40 1/2	46 3/16	54 11/16	63 1/8	71 5/8	80 1/8	97 1/16
	E			35 5/8	39 5/8	43 5/8	49 5/8	55 5/8	61 5/8	67 5/8	79 5/8
60°	M				5 9/16	10 3/16	17 1/8	24 1/16	30 15/16	37 7/8	51 3/4
	C				21 5/16	25 15/16	32 7/8	39 13/16	46 3/4	53 5/8	67 1/2
	K				38 9/16	43 3/16	50 1/8	57 1/16	64	70 15/16	84 3/4
	E				36 9/16	38 7/8	42 3/8	45 13/16	49 1/4	52 3/4	59 11/16
90°	M						5 3/4	11 3/4	17 3/4	23 3/4	35 3/4
	C							28 15/16	34 15/16	40 15/16	52 15/16
	K							54 13/16	60 13/16	66 13/16	78 13/16
	E							38 15/16	38 15/16	38 15/16	38 15/16



VALUES FOR LAYOUT OF COMMON BENDS

Chart H – 3 1/2" EMT

D = 6 9/16		HEIGHT									
ANGLE	DIM	10	12	16	20	24	30	36	42	48	60
15°	M	21 13/16	29 9/16	45	60 7/16	75 15/16	99 1/8	122 1/4	145 7/16	168 5/8	215
	C	38 5/8	46 5/16	61 13/16	77 1/4	92 11/16	115 7/8	139 1/16	162 1/4	185 7/16	231 13/16
	K	43 5/8	51 3/8	66 13/16	82 1/4	97 3/4	120 7/8	144 1/16	167 1/4	190 7/16	236 13/16
	E	48 15/16	56 3/8	71 5/16	86 1/4	101 3/16	123 9/16	145 15/16	168 3/8	190 3/4	235 9/16
30°	M	4 5/16	8 5/16	16 5/16	24 5/16	32 5/16	44 5/16	56 5/16	68 5/16	80 5/16	104 5/16
	C	19 3/4	23 3/4	31 3/4	39 3/4	47 3/4	59 3/4	71 3/4	83 3/4	95 3/4	119 3/4
	K	29 13/16	33 13/16	41 13/16	49 13/16	57 13/16	69 13/16	81 13/16	93 13/16	105 13/16	129 13/16
	E	34 3/16	37 5/8	44 9/16	51 1/2	58 7/16	68 13/16	79 3/16	89 9/16	100	120 3/4
45°	M			5 5/16	10 15/16	16 5/8	25 1/16	33 9/16	42 1/16	50 9/16	67 1/2
	C				27 7/16	33 1/8	41 5/8	50 1/16	58 9/16	67 1/16	84
	K				42 1/2	48 3/16	56 11/16	65 1/8	73 5/8	82 1/8	99 1/16
	E				42 7/16	46 7/16	52 7/16	58 7/16	64 7/16	70 7/16	82 7/16
60°	M					7 3/4	14 11/16	21 5/8	28 9/16	35 1/2	49 5/16
	C						32 9/16	39 1/2	46 7/16	53 3/8	67 1/4
	K						52 11/16	59 9/16	66 1/2	73 7/16	87 5/16
	E						46	49 1/2	52 15/16	56 7/16	63 3/8
90°	M							8 1/4	14 1/4	20 1/4	32 1/4
	C									39 3/4	51 3/4
	K									69 7/8	81 7/8
	E									44 15/16	44 15/16

Chart I – 3 1/2" RIGID/IMC

D = 7		HEIGHT									
ANGLE	DIM	10	12	16	20	24	30	36	42	48	60
15°	M	21 3/8	29 1/8	44 9/16	60	75 1/2	98 11/16	121 13/16	145	168 3/16	214 9/16
	C	38 5/8	46 5/16	61 13/16	77 1/4	92 11/16	115 7/8	139 1/16	162 1/4	185 7/16	231 13/16
	K	43 5/8	51 3/8	66 13/16	82 1/4	97 3/4	120 7/8	144 1/16	167 1/4	190 7/16	236 13/16
	E	49 3/8	56 13/16	71 3/4	86 11/16	101 5/8	124	146 3/8	168 13/16	191 3/16	236
30°	M	3 7/8	7 7/8	15 7/8	23 7/8	31 7/8	43 7/8	55 7/8	67 7/8	79 7/8	103 7/8
	C	19 3/4	23 3/4	31 3/4	39 3/4	47 3/4	59 3/4	71 3/4	83 3/4	95 3/4	119 3/4
	K	29 13/16	33 13/16	41 13/16	49 13/16	57 13/16	69 13/16	81 13/16	93 13/16	105 13/16	129 13/16
	E	34 5/8	38 1/16	45	51 15/16	58 7/8	69 1/4	79 5/8	90	100 7/16	121 3/16
45°	M			4 7/8	10 1/2	16 3/16	24 5/8	33 1/8	41 5/8	50 1/8	67 1/16
	C				27 7/16	33 1/8	41 5/8	50 1/16	58 9/16	67 1/16	84
	K				42 1/2	48 3/16	56 11/16	65 1/8	73 5/8	82 1/8	99 1/16
	E				42 7/8	46 7/8	52 7/8	58 7/8	64 7/8	70 7/8	82 7/8
60°	M				2 11/16	7 5/16	14 1/4	21 3/16	28 1/8	35 1/16	48 7/8
	C						32 9/16	39 1/2	46 7/16	53 3/8	67 1/4
	K						52 11/16	59 9/16	66 1/2	73 7/16	87 5/16
	E						46 7/16	49 15/16	53 3/8	56 7/8	63 13/16
90°	M							7 13/16	13 13/16	19 13/16	31 13/16
	C									39 3/4	51 3/4
	K									69 7/8	81 7/8
	E									45 3/8	45 3/8



VALUES FOR LAYOUT OF COMMON BENDS

Chart J – 4" EMT

D = 8 1/2		HEIGHT									
ANGLE	DIM	10	12	16	20	24	30	36	42	48	60
15°	M	18 5/8	26 5/16	41 13/16	57 1/4	72 11/16	95 7/8	119 1/16	142 1/4	165 7/16	211 13/16
	C	38 5/8	46 5/16	61 13/16	77 1/4	92 11/16	115 7/8	139 1/16	162 1/4	185 7/16	231 13/16
	K	44 1/4	51 15/16	67 7/16	82 7/8	98 5/16	121 1/2	144 11/16	167 7/8	191 1/16	237 7/16
	E	51 1/2	58 15/16	73 7/8	88 13/16	103 3/4	126 1/8	148 1/2	170 15/16	193 5/16	238 1/16
30°	M		5 1/4	13 1/4	21 1/4	29 1/4	41 1/4	53 1/4	65 1/4	77 1/4	101 1/4
	C		23 3/4	31 3/4	39 3/4	47 3/4	59 3/4	71 3/4	83 3/4	95 3/4	119 3/4
	K		35	43	51	59	71	83	95	107	131
	E		40 13/16	47 3/4	54 11/16	61 9/16	72	82 3/8	92 3/4	103 3/16	123 15/16
45°	M				7 11/16	13 3/8	21 13/16	30 5/16	38 13/16	47 5/16	64 1/4
	C				27 3/8	33	41 1/2	50	58 1/2	66 15/16	83 15/16
	K				44 1/4	49 7/8	58 3/8	66 7/8	75 3/8	83 13/16	100 13/16
	E				46 5/16	50 5/16	56 5/16	62 5/16	68 5/16	74 5/16	86 5/16
60°	M					4 3/16	11 1/8	18 1/16	25	31 15/16	45 3/4
	C						32 5/16	39 1/4	46 3/16	53 1/8	67
	K						54 7/8	61 3/4	68 11/16	75 5/8	89 1/2
	E						50 5/8	54 1/8	57 9/16	61 1/16	67 15/16
90°	M								9 3/4	15 3/4	27 3/4
	C										50 3/4
	K										84 9/16
	E										51 1/2

Chart K – 4" RIGID/IMC

D = 8 3/4		HEIGHT									
ANGLE	DIM	10	12	16	20	24	30	36	42	48	60
15°	M	18 3/8	26 1/16	41 9/16	57	72 7/16	95 5/8	118 13/16	142	165 3/16	211 9/16
	C	38 5/8	46 5/16	61 13/16	77 1/4	92 11/16	115 7/8	139 1/16	162 1/4	185 7/16	231 13/16
	K	44 1/4	51 15/16	67 7/16	82 7/8	98 5/16	121 1/2	144 11/16	167 7/8	191 1/16	237 7/16
	E	51 3/4	59 3/16	74 1/8	89 1/16	104	126 3/8	148 3/4	171 3/16	193 9/16	238 5/16
30°	M		5	13	21	29	41	53	65	77	101
	C		23 3/4	31 3/4	39 3/4	47 3/4	59 3/4	71 3/4	83 3/4	95 3/4	119 3/4
	K		35	43	51	59	71	83	95	107	131
	E		41 1/16	48	54 15/16	61 13/16	72 1/4	82 5/8	93	103 7/16	124 3/16
45°	M				7 7/16	13 1/8	21 9/16	30 1/16	38 9/16	47 1/16	64
	C				27 3/8	33	41 1/2	50	58 1/2	66 15/16	83 15/16
	K				44 1/4	49 7/8	58 3/8	66 7/8	75 3/8	83 13/16	100 13/16
	E				46 9/16	50 9/16	56 9/16	62 9/16	68 9/16	74 9/16	86 9/16
60°	M					3 15/16	10 7/8	17 13/16	24 3/4	31 11/16	45 1/2
	C						32 5/16	39 1/4	46 3/16	53 1/8	67
	K						54 7/8	61 3/4	68 11/16	75 5/8	89 1/2
	E						50 7/8	54 3/8	57 13/16	61 5/16	68 3/16
90°	M							3 1/2	9 1/2	15 1/2	27 1/2
	C										50 3/4
	K										84 9/16
	E										51 3/4



CALCULATING "C" VALUES FOR OFFSETS PAST AN OBSTACLE

NOTE: Refer to chart L below and ensure desired height (H) is greater than the minimum height for the size and type of conduit being bent.

Chart L – Minimum Offset Height

ANGLE	15°	30°	45°	60°	90°
2 1/2"	2 9/16	6 13/16	12 1/2	19 1/4	33 15/16
3"	2 11/16	7 7/16	13 7/8	21 11/16	38 15/16
3 1/2"	3 1/8	8 5/8	16 3/16	25 1/4	45 3/8
4"	3 3/4	10 1/8	18 13/16	29 1/16	51 3/4

To determine "C" value for laying out bending marks for offset heights other than those listed, use the following formula:

$$C = A \times H - B$$

"A" is a multiplier corresponding to the angle of bend and can be found in chart M. "B" is a deduct value and can be found in chart N for the size of conduit and angle of bend.

Chart M – "A" Values for Approximating Distances Between Marks for Offsets

ANGLE				
15°	30°	45°	60°	90°
3.86	2.00	1.41	1.15	1.00

Chart N – "B" Values for Approximating Distances Between Marks for Offsets

ANGLE	15°	30°	45°	60°	90°
2 1/2"	0.02	0.17	0.60	1.49	5.97
3"	0.02	0.20	0.71	1.77	7.07
3 1/2"	0.03	0.24	0.83	2.06	8.23
4"	0.03	0.26	0.93	2.31	9.23

EXPLODED VIEW AND PARTS LIST — FOLLOW BARS

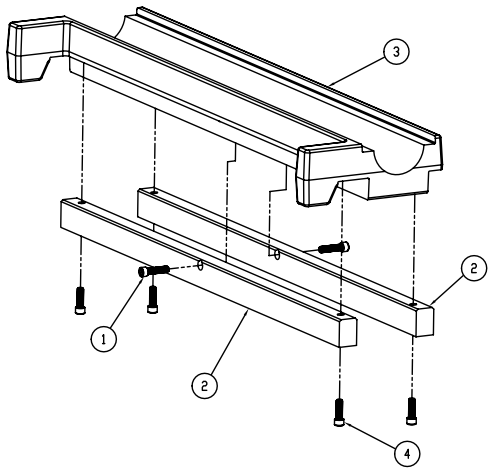

2 1/2"

ITEM #	PART #	QTY.	DESCRIPTION
1	254-004	2	SCREW, SKT. HD. CAP – 5/16-18 x 1 1/4"
2	254-113	2	RAIL
3	254-157	1	FOLLOW BAR LESS RAILS
4	99-60	4	SCREW, SKT. HD CAP – 5/16-18 x 1"

TORQUE ALL SCREWS TO 20 FT-LBS

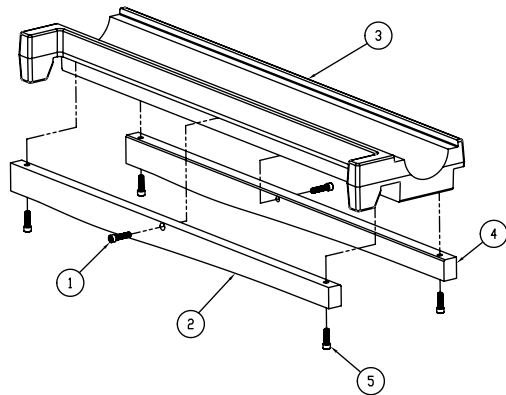

3"

ITEM #	PART #	QTY.	DESCRIPTION
1	254-004	2	SCREW, SKT. HD. CAP – 5/16-18 x 1 1/4"
2	254-120	1	RAIL – LH
3	254-163	1	FOLLOW BAR LESS RAILS
4	254-192	1	RAIL – RH
5	99-60	4	SCREW, SKT. HD CAP – 5/16-18 x 1"

TORQUE ALL SCREWS TO 20 FT-LBS

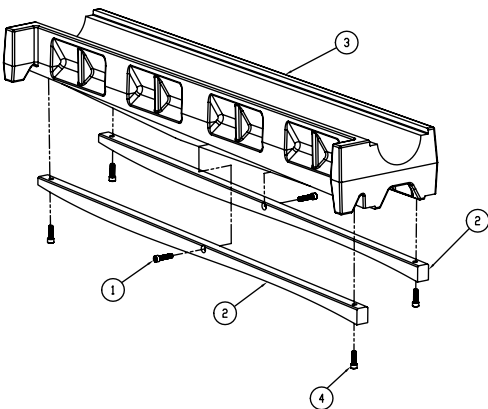

3 1/2"

ITEM #	PART #	QTY.	DESCRIPTION
1	254-004	2	SCREW, SKT. HD. CAP – 5/16-18 x 1 1/4"
2	254-127	2	RAIL
3	254-168	1	FOLLOW BAR LESS RAILS
4	99-60	4	SCREW, SKT. HD CAP – 5/16-18 x 1"

TORQUE ALL SCREWS TO 20 FT-LBS

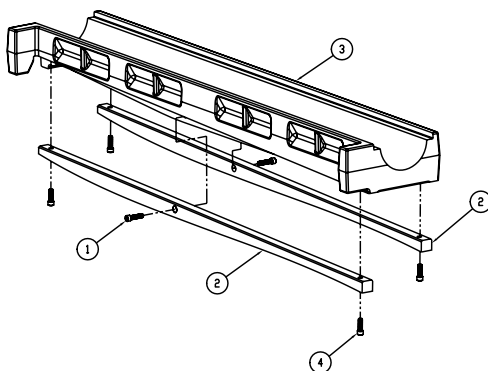

4"

ITEM #	PART #	QTY.	DESCRIPTION
1	254-004	2	SCREW, SKT. HD. CAP – 5/16-18 x 1 1/4"
2	254-134	2	RAIL
3	254-145	1	FOLLOW BAR LESS RAILS
4	99-60	4	SCREW, SKT. HD CAP – 5/16-18 x 1"

TORQUE ALL SCREWS TO 20 FT-LBS

EXPLODED VIEW — SADDLES

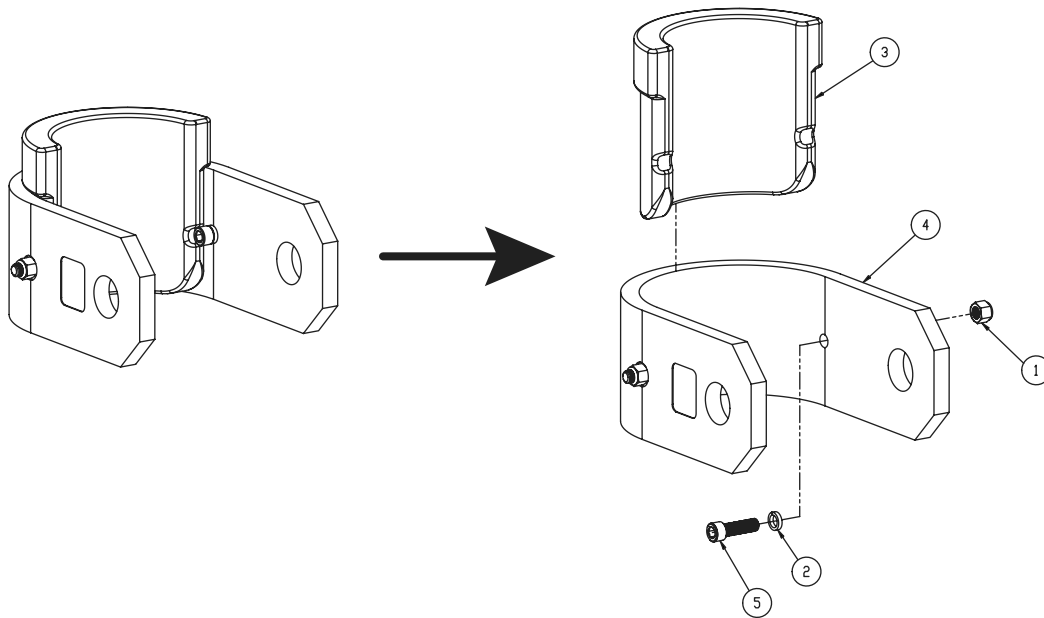

PARTS LIST — SADDLES

2½"

ITEM #	PART #	QTY.	DESCRIPTION
1	2-1501-4	2	NUT – NYLON INSERT 3/8-16
2	254-005	2	WASHER – LOCK, 3/8
3	254-115	1	INSERT – SADDLE, 2½"
4	254-116	1	STRAP – SADDLE, 2½"
5	99-59	2	SCREW – SKT. HD CAP, 3/8-16 × 1.25

3"

ITEM #	PART #	QTY.	DESCRIPTION
1	2-1501-4	2	NUT – NYLON INSERT 3/8-16
2	254-005	2	WASHER – LOCK, 3/8
3	254-122	1	INSERT – SADDLE, 3"
4	254-191	1	STRAP – SADDLE, 3"
5	99-59	2	SCREW – SKT. HD CAP, 3/8-16 × 1.25

3½"

ITEM #	PART #	QTY.	DESCRIPTION
1	2-1501-4	2	NUT – NYLON INSERT 3/8-16
2	254-005	2	WASHER – LOCK, 3/8
3	254-129	1	INSERT – SADDLE, 3½"
4	254-130	1	STRAP – SADDLE, 3½"
5	99-59	2	SCREW – SKT. HD CAP, 3/8-16 × 1.25

4"

ITEM #	PART #	QTY.	DESCRIPTION
1	2-1501-4	2	NUT – NYLON INSERT 3/8-16
2	254-005	2	WASHER – LOCK, 3/8
3	254-136	1	INSERT – SADDLE, 4"
4	254-137	1	STRAP – SADDLE, 4"
5	99-59	2	SCREW – SKT. HD CAP, 3/8-16 × 1.25

EXPLODED VIEW — HYDRAULIC CYLINDER

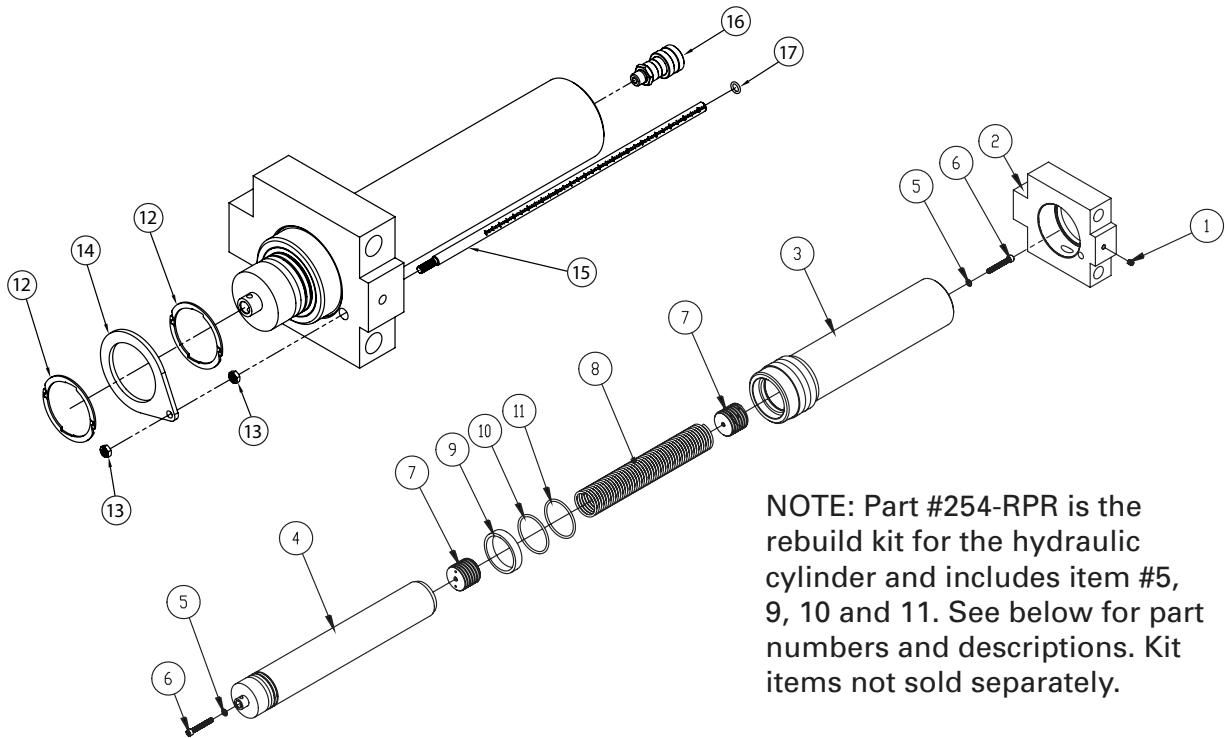

PARTS LIST — HYDRAULIC CYLINDER

ITEM #	PART #	QTY.	DESCRIPTION
1	254-011	1	SCREW-SET, 7/16-14 x 1/2"
2	254-102	1	CYLINDER BLOCK
3	254-401	1	BARREL
4	254-402	1	ROD
5	254-404	2	GASKET (COPPER)
6	254-405	2	SCREW-SKT. HD. CAP, 3/8-16 X 2 3/4"
7	254-406	2	SPRING RETAINER
8	254-407	1	EXTENSION SPRING
9	254-408	1	BUSHING
10	254-409	1	BACK-UP RING
11	254-410	1	O-RING
12	254-010	2	RING-RETAINING, EXTERNAL INTERLOCKING
13	254-009	2	NUT-HEX, THIN 3/8-24
14	254-188	1	PLATE-GAUGE ROD
15	254-189	1	ROD-GAUGE
16	291-2A	1	FITTING-HYDRAULIC, FEMALE
17	254-007	1	O-RING, RUBBER

REBUILD KIT — HYDRAULIC CYLINDER

ITEM #	PART #	QTY.	DESCRIPTION
5	254-404	2	GASKET (COPPER)
9	254-408	1	BUSHING
10	254-409	1	BACK-UP RING
11	254-410	1	O-RING

WARNING

ALWAYS disconnect the bender from the hydraulic pump before servicing and when not in use.

Problem	Cause	Cure
Kinking or rippling of EMT conduit.	Clevis pin is inserted in the shoe hole for Rigid/IMC conduit.	Move clevis pin to the shoe hole marked for EMT conduit (see Figure 10A on page 10).
	Follow bar is in backwards.	Remove follow bar and install with the end marked "START" just past the roller assembly (see Figure 10C on page 10).
	Shoe and/or follow bar grooves are dirty or damaged.	Clean grooves of shoe and follow bar. Replace if damaged.
	Saddle and follow bar are not positioned properly at the start of the bend.	Position follow bar and saddle as shown in Figure 12A on page 12 of the manual.
	Shoe and/or follow bar grooves are damaged or worn.	Replace as necessary.
	Roller assembly is not turning on the shaft.	Disassemble roller and lubricate roller shaft with a multi-purpose grease. Repair or replace as necessary.
Side marking of EMT conduit.	Conduit is not level. (Floor set up only)	Level the conduit in the set up.
	Shoe and/or follow bar grooves are dirty or damaged.	Clean grooves of shoe and follow bar. Replace if damaged.
	Carriage with vise on the Model #281 bending table is clamped too close to the bender.	Adjust the position of the carriage with vise further from the bender.
	Follow bar groove is damaged or worn.	Replace as necessary.
	Follow bar not centered on the roller assembly at start of bend	Center the follow bar on the roller assembly.
Will not bend EMT.	Follow bar is in backwards.	Remove follow bar and install with the end marked "START" just past the roller assembly (see Figure 10C on page 10).
Kinking or rippling of Rigid or IMC conduit.	Follow bar is in backwards	Remove follow bar and install with the end marked "START" just past the roller assembly (see Figure 10C on page 10).
Side marking of Rigid or IMC conduit	Conduit is not level (floor set up only)	Level the conduit in the setup.
	Follow bar not centered on roller assembly at start of bend.	Center the follow bar on the roller assembly.
Problem	Cause	Cure

 **WARNING**

ALWAYS disconnect the bender from the hydraulic pump before servicing and when not in use.

<p>Will not bend Rigid or IMC conduit.</p>	<p>Clevis pin is inserted in the shoe hole for EMT conduit.</p>	<p>Move clevis pin to the shoe hole marked for Rigid/IMC conduit (See Figure 10A on page 10).</p>
	<p>Follow bar is in backwards.</p>	<p>Remove follow bar and install with the end marked "START" just past the roller assembly (see Figure 10C on page 10).</p>
<p>Hydraulic cylinder will not advance.</p>	<p>Hydraulic pump is low on oil.</p>	<p>Refer to operating instructions for the hydraulic pump and add oil.</p>
	<p>Hydraulic fittings are not fully tightened.</p>	<p>Check all hydraulic fittings and tighten.</p>
	<p>Too long of an extension cord causing voltage drop to the hydraulic pump.</p>	<p>Use heavier gauge extension cord and/or shorter extension cord.</p>
	<p>Pump not properly vented.</p>	<p>Remove the plug used during shipping and replace with the correct vent plug.</p>
	<p>Hydraulic cylinder pinned too high in the frame for the size conduit being bent.</p>	<p>Reposition hydraulic cylinder to the proper position in the frame.</p>
	<p>Pump valve lever in wrong position.</p>	<p>Rotate pump valve lever to the closed position.</p>
	<p>Pump not operating properly.</p>	<p>Check pump manual for trouble shooting.</p>
<p>Hydraulic cylinder advancing slowly</p>	<p>Pump valve not fully closed</p>	<p>Ensure pump valve lever is in the fully closed position</p>