



Current Tools

FOR THE PROFESSIONAL ELECTRICIAN

Current Tools™ Offset Benders

Model 705 — 1/2" EMT Conduit
Model 706 — 3/4" EMT Conduit

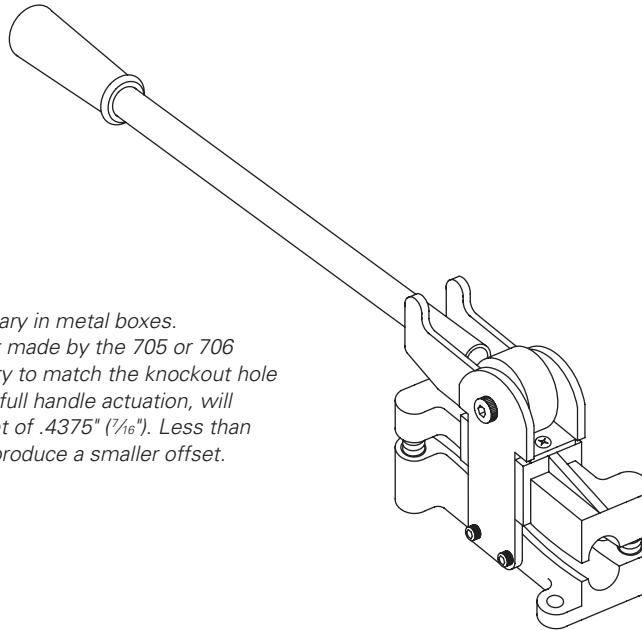

Knockout hole locations vary in metal boxes. Adjustments to the offset made by the 705 or 706 benders may be necessary to match the knockout hole location. Either unit, with full handle actuation, will achieve a maximum offset of .4375" (7/16"). Less than full handle actuation will produce a smaller offset.

Operating, Safety and Parts Manual

08/10 REV. 3



Read and understand this material before using the Offset Bender. Failure to understand how to safely operate this unit could result in personal injury.

This manual is free of charge. All personnel who operate the Offset Bender should have a copy of this manual and read and understand its contents. To request a copy, call or write to the address below. All information, specifications and product designs may change due to design improvements or updates and are subject to change without notice. Current Tools does not assume any liability for damages resulting from misuse or incorrect application of its products.

CURRENT TOOLS • P. O. BOX 17026 GREENVILLE, SC 29606
800.230.5421 or 864-721-4230 • FAX 864-721-4232
www.currenttools.com

OPERATING INSTRUCTIONS

1. Slide conduit into bender so that end of conduit sticks out of the low side of the bender. (See *Figure A*).
2. Push handle down as shown in *Figure A*.
3. Pull handle up to release bent conduit.

NOTE: *Two mounting holes are located on the base of the offset bender. These can be used to mount the offset bender to a work table or other work surface.*

CAUTION

For use **ONLY** with EMT Conduit.

Damage will occur to bender if used with IMC or RIGID conduit.

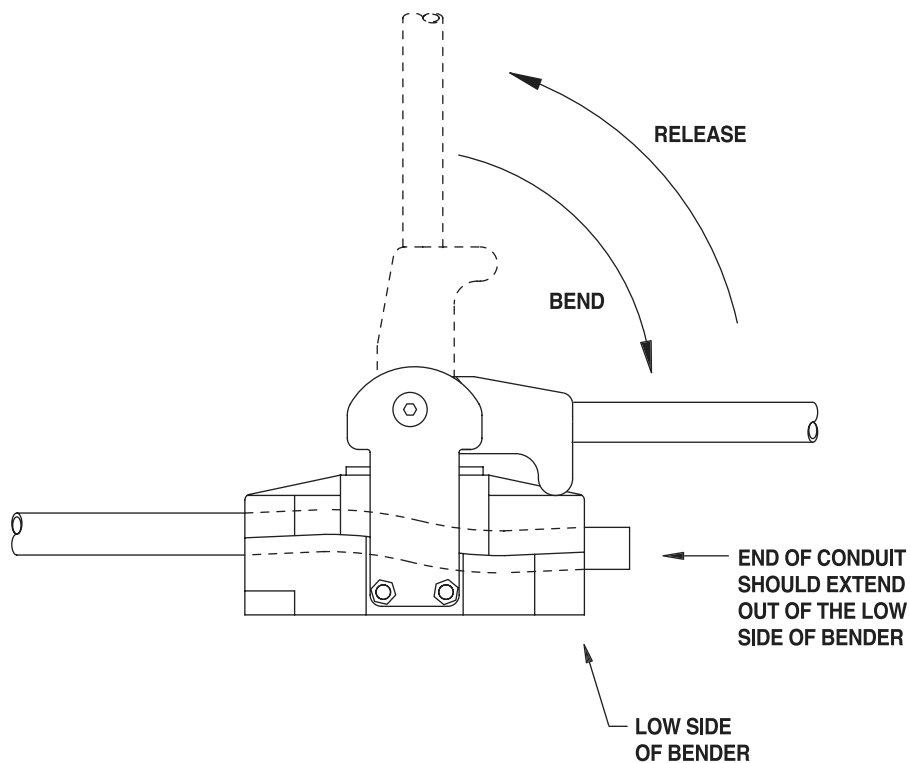
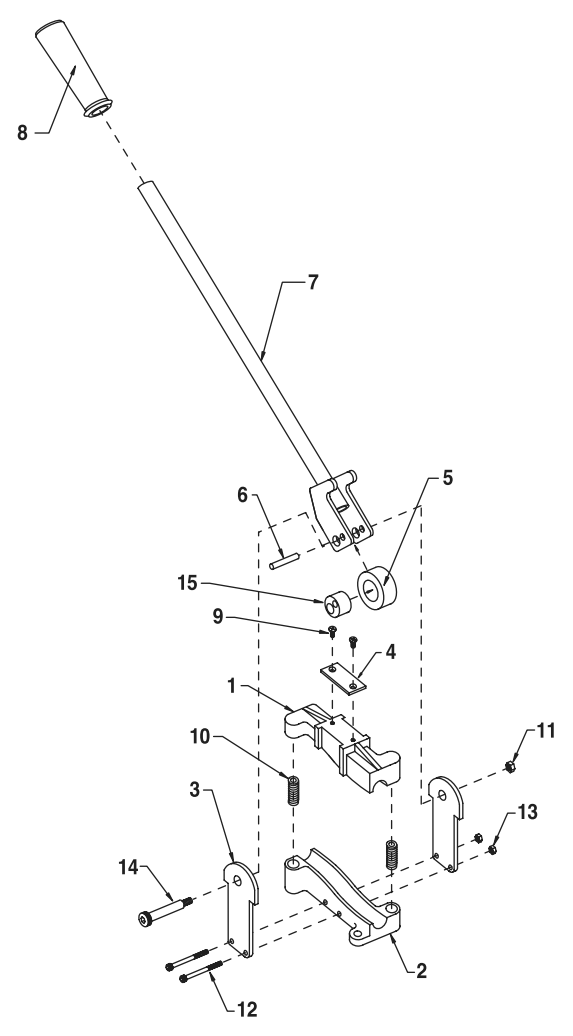

Figure A

EXPLODED VIEW



PARTS LIST — Models 705 and 706 Offset Benders

ITEM#	705 PART#	706 PART#	QTY	DESCRIPTION
1	705-629	706-631	1	UPPER BLOCK
2	705-628	706-630	1	LOWER BLOCK
3	705-273	705-273	2	SLIDE PLATE
4	705-298	705-298	1	WEAR PLATE
5	705-310	705-310	1	LARGE ROLLER
6	705-6	705-6	1	PIN - ROLLER
7	705-270	705-270	1	HANDLE
8	705-8	705-8	1	GRIP
9	705-9	705-9	2	SCREW #10 - 24 x 1/2" FLAT PHILLIPS
10	705-10	705-10	2	SPRING - COMPRESSION
11	2-1501-4	2-1501-4	1	NUT-HEX, 3/8" - 16 (NYLOK)
12	705-12	705-12	2	SCREW-SOC. HD. CAP 5/16" - 18 x 2 1/4"
13	412-8	412-8	2	NYL. INS. NUT-HEX, 5/16" - 18
14	705-14	705-14	1	SCREW-SHOULDER SOC. 1/2" x 2"
15	705-310A	705-310A	1	SMALL ROLLER