



Current Tools

FOR THE PROFESSIONAL ELECTRICIAN

Current Tools™ Mechanical Bender

Model 750 — ½" to 1"

RIGID and IMC conduit and schedule 40 Pipe

with **TWEAKER™**

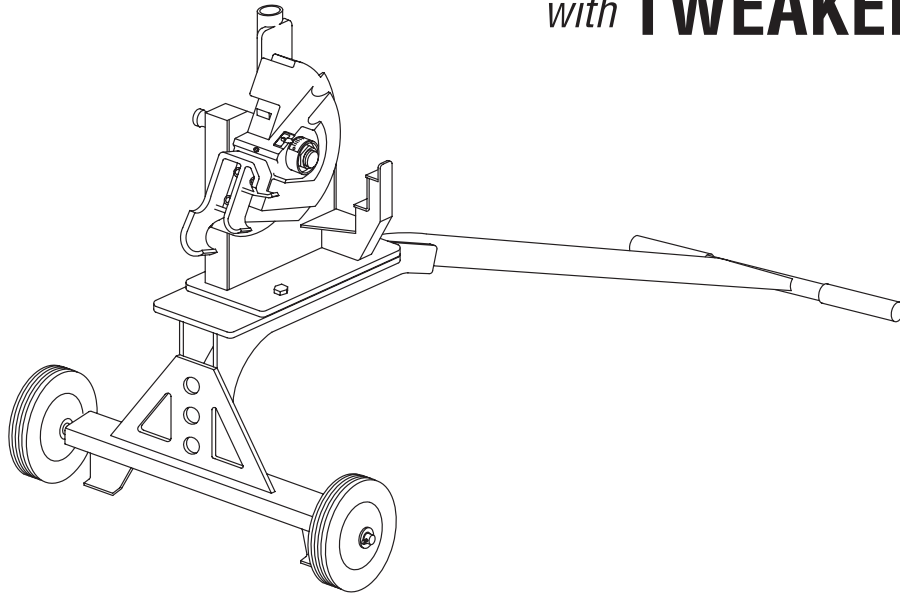

Operating, Maintenance, Safety and Parts Manual

06/11 REV. 4



Read and understand this material before operating or servicing the Mechanical Bender. Failure to understand how to safely operate and service this unit could result in serious injury or death.

This manual is free of charge. All personnel who operate the Mechanical Bender should have a copy of this manual and read and understand its contents. To request a copy, call or write to the address below. All information, specifications and product designs may change due to design improvements or updates and are subject to change without notice. Current Tools does not assume any liability for damages resulting from misuse or incorrect application of its products.

CURRENT TOOLS • P. O. BOX 17026 GREENVILLE, SC 29606
800.230.5421 or 864-721-4230 • FAX 864-721-4232
www.currenttools.com



TABLE OF CONTENTS

Safety Alerts	2
Safety Information	3
Specifications	4
Operating Instructions	4
The TWEAKER™	5
Maintenance	5
Stub Bending Information	6
Offset Bending Information	7
Exploded View	8
Parts List — Model 750 Mechanical Bender	9



SAFETY ALERTS



Safety Alert Symbol

THIS SAFETY SYMBOL is used to call your attention to instructions that concern your personal safety. It means: ATTENTION! BE AWARE! THIS IS AN IMPORTANT SAFETY INSTRUCTION!

Read, understand, and follow these safety instructions. Failure to follow these safety instructions may result in injury or death.



DANGER

Immediate hazards which, if not avoided, WILL result in serious personal injury or death.



WARNING

Hazards or unsafe practices which, if not avoided, COULD result in serious personal injury or death.



CAUTION

Hazards or unsafe practices which, if not avoided, COULD result in minor personal injury or property damage.

RETAIN SAFETY INFORMATION



This manual should be read and understood by all personnel who operate or service this Mechanical Bender. Failure to understand how to safely operate and service this unit could result in injury or death. This unit should only be operated or serviced by qualified personnel.



IMPORTANT SAFETY INFORMATION

Follow ALL safety information provided by the manufacturer.

- ▲ WARNING** Keep hands and feet away from pinch points such as bending shoe, ratchet handle and conduit when operating the bender.
- ▲ WARNING** Do NOT leave the ratchet handle in the up position. The handle could fall and cause serious injury.
- ▲ WARNING** Do NOT force tool. If bend cannot be completed with the 5' section of 1" RIGID conduit used as a ratchet handle, discontinue bend and determine cause before continuing. Do NOT use a ratchet handle longer than 5' of 1" RIGID conduit.
- ▲ WARNING** Do NOT stand on the bender. Serious injury could occur if bender is tipped.
- ▲ CAUTION** ALWAYS keep conduit under control when unloading. Conduit not under control could injure the operator or others in the area.
- ▲ CAUTION** ALWAYS inspect the bender before operating. Replace any damaged, missing or worn parts.
- ▲ CAUTION** WEAR approved safety glasses when using the bender.
- ▲ CAUTION** Bender MUST be used on a firm, flat surface. Do NOT use on an inclined surface.
- ▲ CAUTION** ALWAYS keep the path of the bending conduit clear of obstructions.
- ▲ CAUTION** Keep firm hand pressure on the ratchet handle while bending. The stored energy of bending conduit could cause the ratchet handle to spring forward and strike operator or nearby personnel.
- ▲ CAUTION** REMOVE the ratchet handle and conduit before moving the bender.
- ▲ CAUTION** Keep firm control of the bender T-handle when moving the bender to avoid tipping over.
- ▲ CAUTION** ONLY use the bender for its intended purpose. Only use the bender to bend the specified types and sizes of conduit and pipe.
- ▲ CAUTION** Bender is heavy and requires more than 1 person to lift.

SPECIFICATIONS

Model No.	750
Capacity	½" to 1" RIGID and IMC conduit and schedule 40 pipe
Overall Dimensions	48" L x 24 ½" W x 30" H
Weight	91 lbs.

OPERATING INSTRUCTIONS

1. Cut a 5' length of 1" RIGID conduit and insert it into the ratchet arm as shown in Figure 1. This will serve as the ratchet handle.
2. Place the ratchet handle in the up position. This will release the ratchet pawl. Rotate the bending shoe counter-clockwise. Then lower the ratchet handle.
3. Slide the conduit to be bent over the corresponding size on the conduit support unit, through the shoe groove and bending hook.
4. Place the bending mark on the conduit in line with the front edge of the bending hook. See Figure C on page 6.
5. Raise the ratchet handle until the pawl clicks. Push the ratchet handle down. Repeat until you have completed the desired bend.

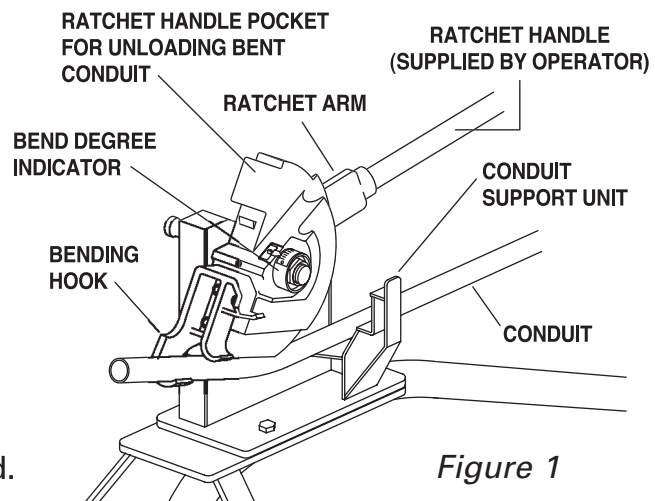

Figure 1

6. To remove bent conduit, raise the ratchet handle to the up position. Remove the ratchet handle from the ratchet arm and slide it into the pocket provided on the bending shoe. While holding the bent conduit, slowly rotate the bending shoe in the counter-clockwise direction and remove the bent conduit.
7. Place the ratchet handle back into the ratchet arm and lower the ratchet handle to the down position.

NOTE: *Springback compensation is not calculated on the bending degree indicator.*

NOTE: *When not in use the ratchet handle MUST remain in the down position.*

THE TWEAKER™

The TWEAKER™ feature allows the operator to correct overbends of 3° or less on ½"–¾"–1" RIGID/IMC conduit or schedule 40 pipe.

To use the TWEAKER™:

1. Insert the conduit between the TWEAKER™ shafts shown on Figure 2.
2. Apply pressure to conduit as needed to correct overbend.

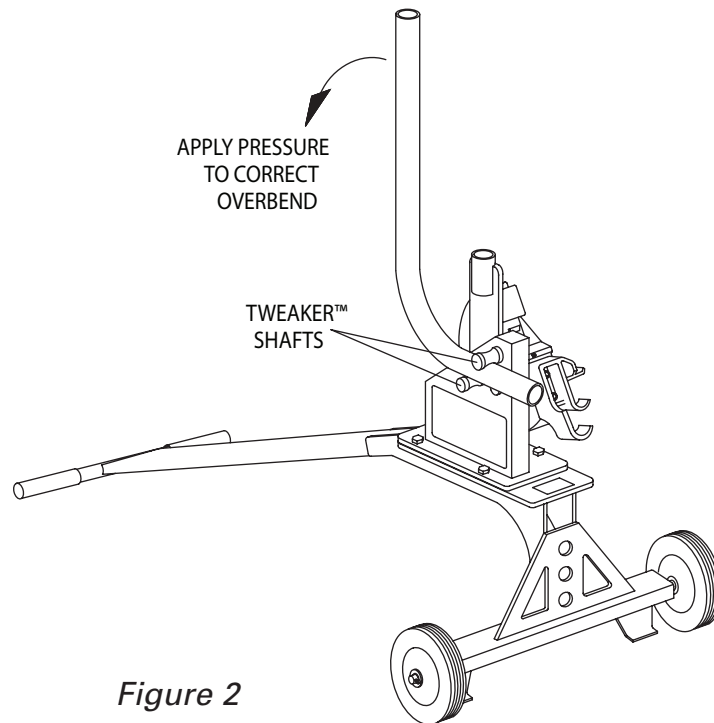

Figure 2

CAUTION

Maintain balance and keep control of conduit when using the TWEAKER™.

MAINTENANCE

Monthly: Apply multi-purpose grease at grease fitting.
See Item #27 on Exploded View on Page 8.

Monthly: Apply a few drops of oil into oil hole on bending shoe.
See Item #1 on Exploded View on Page 8.

STUB BENDING INFORMATION

To locate bending marks for stubs:

1. Check the Stub Dimensions Chart (*below*) for Minimum Stub Length. The stub being bent must be equal to or longer than the Minimum Stub Length.
2. Measure and mark the stub length required on the conduit. This is the stub length mark. *See Figure A.* Locate the Deduct Length on the Stub Dimensions Chart (*below*). Deduct this length from the stub length mark and make a second mark. This is the bending mark. *See Figure A.*
3. Put the conduit in the bender and place the bending mark in line with the front edge of the shoe hook. The conduit must extend at least 1" past the shoe hook. *See Figure C.* Complete the bend.

Stub Dimensions Chart *Figures are approximate.*

Conduit Size	Centerline Bending Radius	Minimum Stub Length	Deduct Length
1/2"	* 2 ⁵ / ₈ "	6 ¹ / ₂ "	5 ¹ / ₂ "
3/4"	4 ⁵ / ₈ "	9 ¹ / ₂ "	8 ¹ / ₂ "
1"	5 ⁷ / ₈ "	12"	11"

*1/2" conduit must be bent in the 3/4" groove to make a bend with a radius greater than 4". This will meet electrical code.

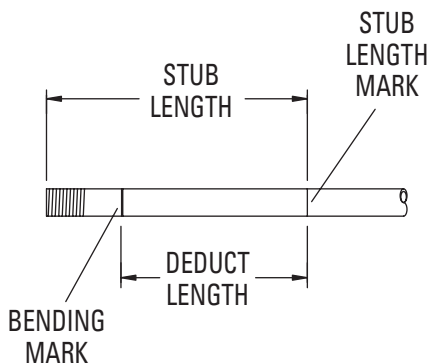

FIGURE A

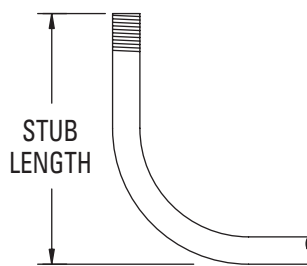

FIGURE B

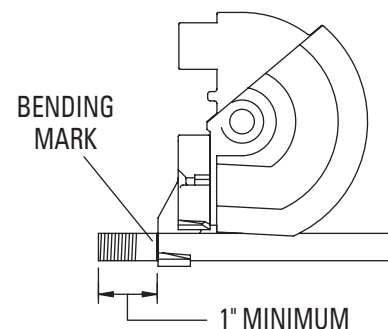

FIGURE C

OFFSET BENDING INFORMATION

To mark conduit for offsets:

1. Measure distance from end of conduit to start of first bend and mark conduit. This is mark #1. *See Figure 1 and 2.*
2. Refer to Deduct Chart and deduct this length from mark #1 and place mark #2 on conduit. *See Figure 1.*
3. Measure the height of the obstacle. This is the offset height. Refer to the Center-to-Center Chart to locate the next mark. Measure the center-to-center distance from mark #2 and place mark #3 on conduit. *See Figure 1.*
4. Layout of bends is now complete. Next, place mark #2 in line with front edge of shoe hook and make first bend. Note: Conduit must extend at least 1" past front edge of shoe hook. *See Figure C on page 6.*
5. Rotate conduit in the bender 180°. Place mark #3 in line with front edge of shoe hook and complete second bend.

Deduct Chart

Conduit Size	Deduct Length
1/2"	2 1/2"
3/4"	3 1/4"
1"	4 1/4"

Figures are approximate.

Center-to-Center Chart *Figures are approximate.*

Offset Height		2	4	6	8	10	12	14	16	18	20	22
15°	Max Conduit Size	3/4"										
	Center-to-Center	7 3/4"	15 7/16"	23 3/16"	30 15/16"	38 5/8"	46 3/8"	54 1/16"	61 13/16"	69 9/16"	77 1/4"	85"
30°	Max Conduit Size	3/4"										
	Center-to-Center	8"	12"	16"	20"	24"	28"	32"	36"	40"	44"	
45°	Max Conduit Size	1/2"										
	Center-to-Center	8 1/2"	11 15/16"	14 1/8"	16 15/16"	19 13/16"	22 5/8"	25 7/16"	28 1/4"	31 1/8"		

To locate the center-to-center distance of offset bending marks other than those listed in the above chart, use the following multipliers. Multiply the height of offset desired by 3.86 on 15° bends, 2 on 30° bends, and 1.4 on 45° bends.

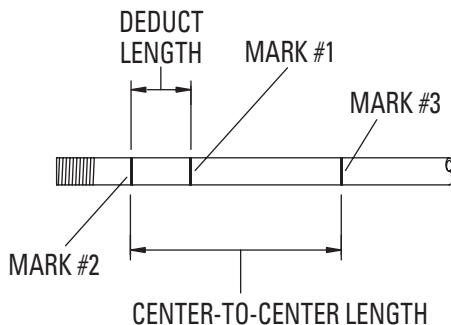

FIGURE 1

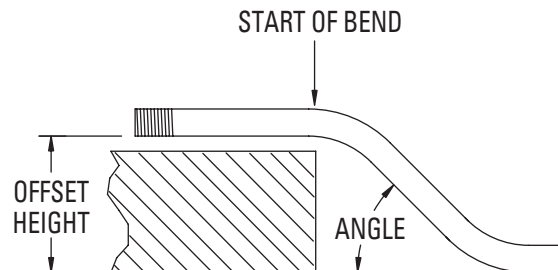
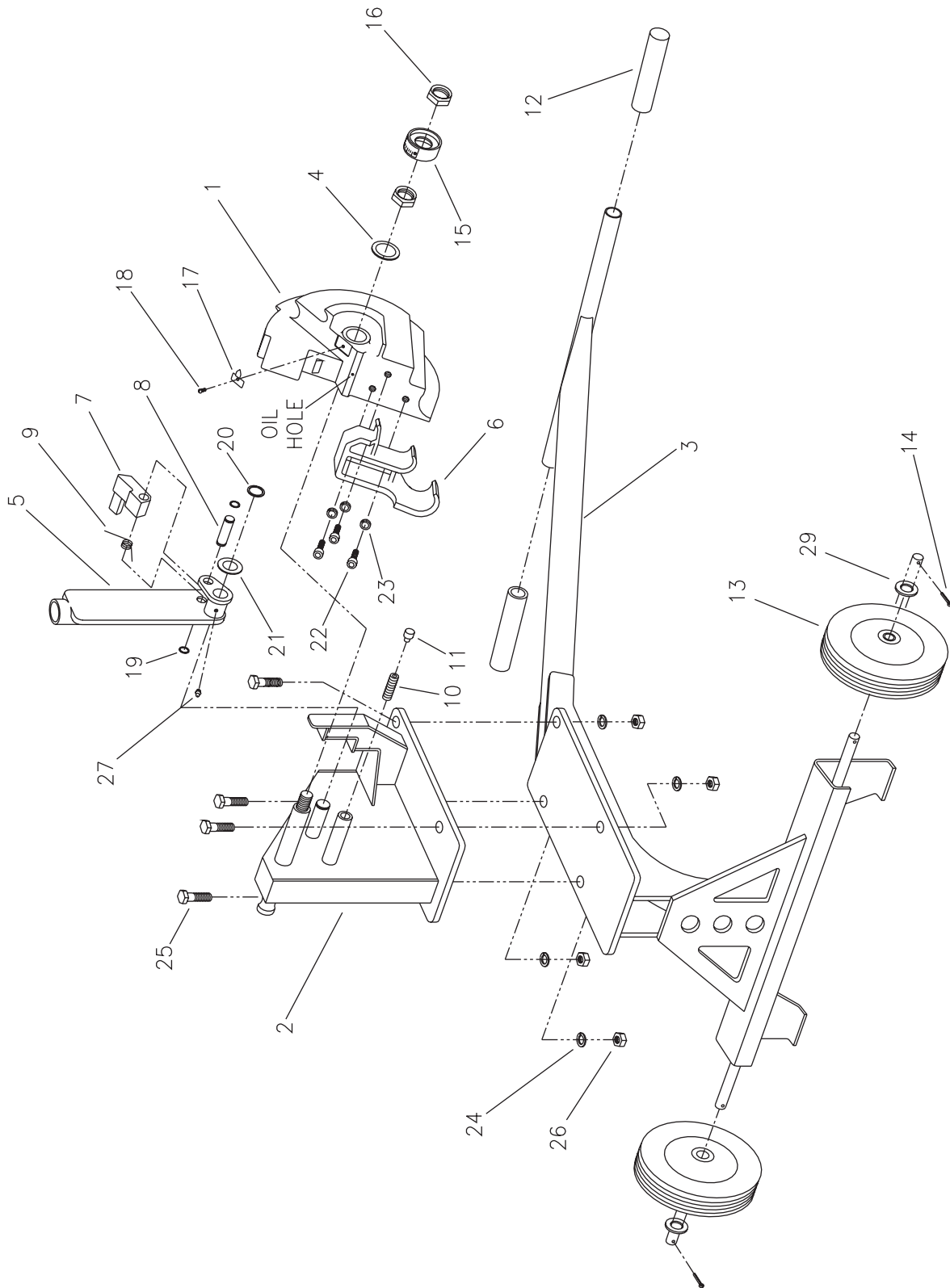

FIGURE 2



EXPLODED VIEW — Model 750 Mechanical Bender





PARTS LIST — Model 750 Mechanical Bender

<u>ITEM #</u>	<u>PART #</u>	<u>QTY</u>	<u>DESCRIPTION</u>
1	750-1	1	BENDING SHOE
2	750-418	1	BENDER HOUSING
3	750-668	1	ROLLING STAND
4	750-13	1	WASHER – FLAT 7/8 SAE
5	750-335	1	RATCHET ARM
6	750-15	1	BENDING HOOK
7	750-330	1	RATCHET PAWL
8	750-347	1	RATCHET PIN
9	750-10	1	TORSION SPRING
10	750-9	1	PRESSURE SPRING
11	750-294	1	PRESSURE PLUG
12	504-1	2	GRIP
13	509-13	2	WHEEL
14	77-016	2	COTTER PIN
15	750-349	1	BENDING DEGREE INDICATOR
16	750-18	2	7/8"-9 HEX LOCK NUTS (THIN)
17	750-382	1	INDICATOR ARROW
18	750-20	1	1/4"-20 X 1/2" HEX HD SCREW
19	750-21	2	RETAINING RING – 1/2"
20	750-22	1	RETAINING RING – 1"
21	750-394	1	WASHER
22	750-25	3	3/8"-16 X 1" HEX HD SCREW
23	452-27	3	3/8" LOCK WASHER
24	281-2C	4	1/2" LOCK WASHER
25	281-1F	4	1/2"-13 X 1 1/2" HEX CAP SCREW
26	280-2G	4	1/2"-13 HEX NUT
27	88-39	1	GREASE FITTING
28	750-M	1	DECAL SET (NOT SHOWN)
29	77-017	2	WASHER – FLAT, 3/4 SAE