



Current Tools

FOR THE PROFESSIONAL ELECTRICIAN

Model 308 / 310 / 312 Manhole Sheave 4,000 lb. Capacity

TOP SHEAVE SHOULD BE IN THE LOWEST
POSITION ABOVE GROUND LEVEL

SHEAVE

⚠ WARNING

Read, understand, and follow setup instructions carefully. Improper setup could cause serious injury or damage to equipment.

MANHOLE SHEAVE
FRAME SHOULD BE
BRACED AGAINST
THE INSIDE OF
THE MANHOLE

SHEAVE

THE LOWER SHEAVE HOOK SHOULD
BE SECURELY ANCHORED TO THE
BOTTOM OF THE MANHOLE

⚠ WARNING

Do not climb on manhole sheave.

⚠ WARNING

Manhole MUST be unoccupied during pull.

- Manhole sheave frame should be braced against the inside of the manhole
- Top sheave should be in the lowest position above ground level.

- The lower sheave hook should be securely anchored to the bottom of the manhole.
- Position the sheaves to avoid pulling the rope across sharp edges.
- Inspect thoroughly for missing, worn, or damaged parts.
- Inspect manhole sheave before each use and ensure that all parts are in good working order.

CURRENT TOOLS • P. O. BOX 17026 GREENVILLE, SC 29606
800.230.5421 or 864.721.4230 • FAX 864.721.4232 • www.currenttools.com

EXPLODED VIEW AND PARTS LIST

*4,000 lb. Capacity — All Models

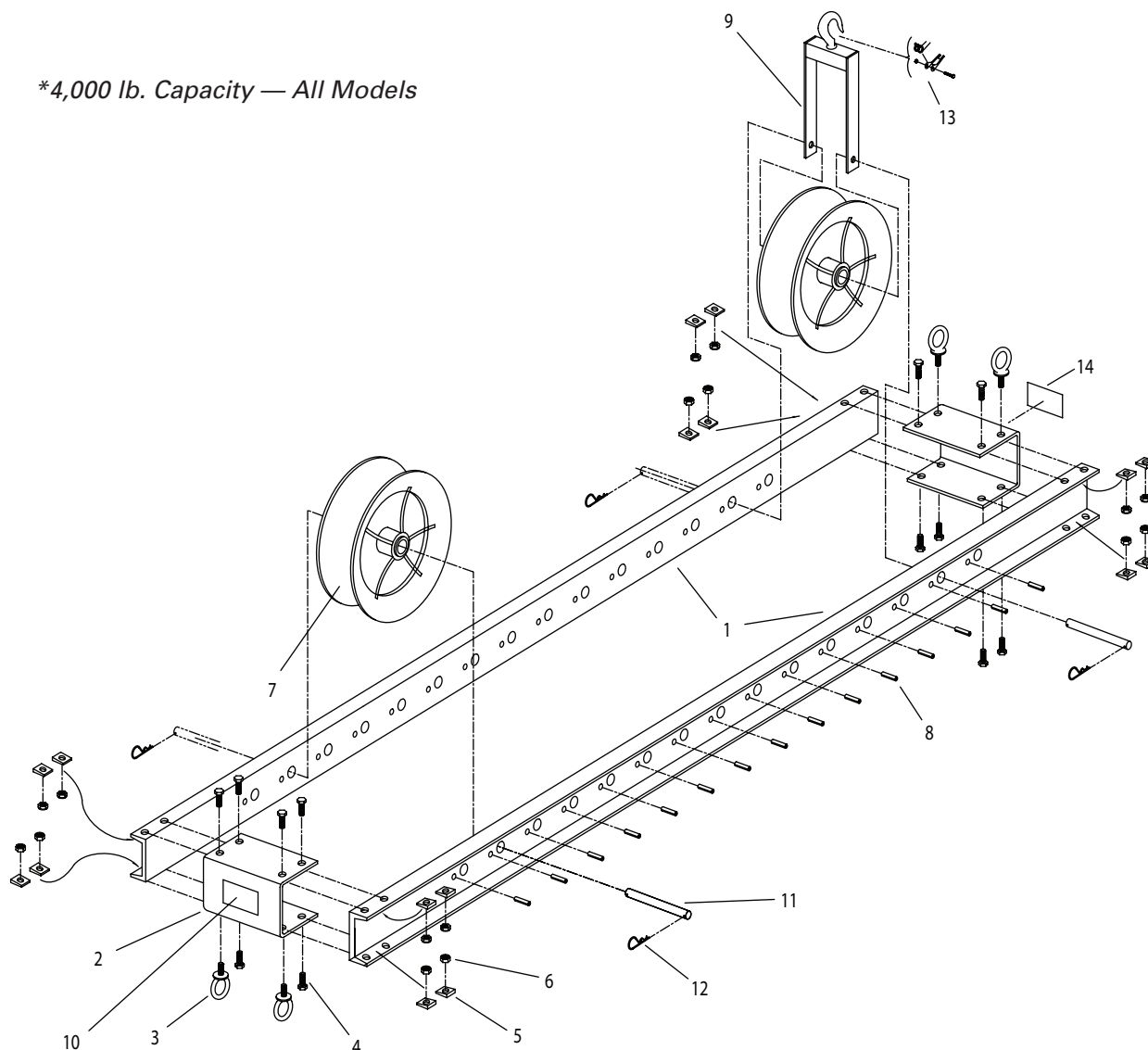

308				310				312			
ITEM #	QTY	PART NO.	DESCRIPTION	QTY	PART NO.	DESCRIPTION	QTY	PART NO.	DESCRIPTION		
1	2	308-387	CHANNEL – ALUM	2	310-641	CHANNEL – ALUM	2	312-642	CHANNEL – ALUM		
2	2	312-140	END – MANHOLE SHEAVE	2	312-140	END – MANHOLE SHEAVE	2	312-140	END – MANHOLE SHEAVE		
3	4	308-3	EYEBOLT – 1/2-13 X 1-1/2	4	308-3	EYEBOLT – 1/2-13 X 1-1/2	4	308-3	EYEBOLT – 1/2-13 X 1-1/2		
4	12	281-1F	SCREW – HEX 1/2-13 X 1.5	12	281-1F	SCREW – HEX 1/2-13 X 1.5	12	281-1F	SCREW – HEX 1/2-13 X 1.5		
5	16	308-5	WASHER – BEVEL 1/2" STEEL	16	308-5	WASHER – BEVEL 1/2" STEEL	16	308-5	WASHER – BEVEL 1/2" STEEL		
6	16	333-7	NUT – LOCK 1/2-13 (NYLON INSERT)	16	333-7	NUT – LOCK 1/2-13 (NYLON INSERT)	16	333-7	NUT – LOCK 1/2-13 (NYLON INSERT)		
7	2	412-4	SHEAVE UNIT – 12" (COMPL)	2	418-4	SHEAVE UNIT – 18" (COMPL)	2	418-4	SHEAVE UNIT – 18" (COMPL)		
8	11	308-6	PIN – ROLL 5/16 X 7/8	15	308-6	PIN – ROLL 5/16 X 7/8	19	308-6	PIN – ROLL 5/16 X 7/8		
9	1	418-192B	HANGER – 18" HOOK SHEAVE (NO STOP)	1	418-192B	HANGER – 18" HOOK SHEAVE (NO STOP)	1	418-192B	HANGER – 18" HOOK SHEAVE (NO STOP)		
10	1	308-DECAL	MODEL # / CAPACITY DECAL	1	310-DECAL	MODEL # / CAPACITY DECAL	1	312-DECAL	MODEL # / CAPACITY DECAL		
11	2	308-599	PIN – SHEAVE 3/4" DIA X 7-5/8"	2	308-599	PIN – SHEAVE 3/4" DIA X 7-5/8"	2	308-599	PIN – SHEAVE 3/4" DIA X 7-5/8"		
12	4	406-3	CLIP – SPRING	4	406-3	CLIP – SPRING	4	406-3	CLIP – SPRING		
13	1	406-1A1	LATCH KIT	1	406-1A1	LATCH KIT	1	406-1A1	LATCH KIT		
14	1	406-1D	DECAL – 4,000 LB. CAP.	1	406-1D	DECAL – 4,000 LB. CAP.	1	406-1D	DECAL – 4,000 LB. CAP.		