

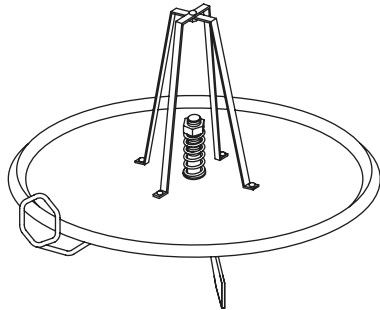

# **Current Tools**

FOR THE PROFESSIONAL ELECTRICIAN

## **Current Tools™ Model 509 & Model 509M Armored Cable Dispensers**



*Model 509*

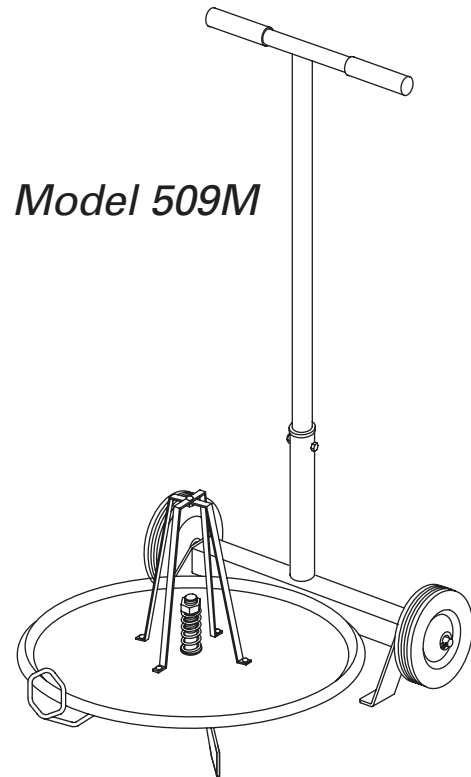

*Model 509M*

## **Operating, Safety, and Parts Manual**

07/10 – REV. 2



**Read and understand this material before operating the Cable Dispenser. Failure to understand how to safely operate this unit may result in injury or property damage.**

This manual is free of charge. All personnel who operate the Cable Dispensers should have a copy of this manual and read and understand its contents. To request a copy, call or write to the address below. All information, specifications and product designs may change due to design improvements or updates and are subject to change without notice. Current Tools does not assume any liability for damages resulting from misuse or incorrect application of its products.

**CURRENT TOOLS • P. O. BOX 17026 GREENVILLE, SC 29606**  
**800.230.5421 or 864-721-4230 • FAX 864-721-4232**  
**[www.currenttools.com](http://www.currenttools.com)**

# TABLE OF CONTENTS

**Important Safety Information** . . . . . 2

**Specifications** . . . . . 2

**Features** . . . . . 3

**Operating Instructions** . . . . . 3

**Parts Lists** . . . . . 3-4

## RETAIN SAFETY INFORMATION



This manual should be read and understood by all personnel who operate the Cable Dispenser. Failure to understand how to safely operate this unit could result in injury or property damage. This unit should only be operated by qualified personnel.

# IMPORTANT SAFETY INFORMATION

Follow ALL safety information provided by the manufacturer.

- CAUTION** Do NOT stand on Cable Dispensers. They may become unstable and cause injury or damage to unit.
- CAUTION** Do NOT overload Cable Dispensers. Maximum dispensing capacity is 50 lbs.
- CAUTION** Do NOT attempt to transport the 509 Cable Dispenser with cable on it.
- CAUTION** ONLY transport cable reels to be dispensed on 509M Cable Dispenser. Transporting other loads may damage unit.
- CAUTION** Stay CLEAR of Cable Dispenser while in use.

# SPECIFICATIONS

|                            |   |   |
|----------------------------|---|---|
| <b>Model No.</b>           | 509   | 509M  |
| <b>Dispensing Capacity</b> | 250' — one coil 14/2, 14/3, 12/2 or 12/3 MC cable or 1 coil unboxed Romex®* | 250' — one coil 14/2, 14/3, 12/2 or 12/3 MC cable or 1 coil unboxed Romex®* |
|                            | <b>NOTE: Not for transporting cable</b>                                     | <b>NOTE: May transport up to 3 coils up to 150 lbs. total weight.</b>       |
| <b>Unit Weight</b>         | 25 lbs.   | 48 lbs.   |
| <b>Height</b>              | 26"   | 43"   |
| <b>Length</b>              | 24"   | 35¼"  |
| <b>Width</b>               | 24"   | 24½"  |

\*Romex is a registered trademark of Southwire Company, LLC.

## FEATURES

- Sturdy steel construction for rugged use.
- Convenient T-handle and durable wheels on 509M for easy mobility.
- Fits through a standard 32" doorway.
- Includes an adjustable spring to set the drag required and to prevent over-feeding.
- Cable guide pivots for tangle-free spooling in any direction.

## OPERATING INSTRUCTIONS

1. Remove all ties or straps from coil of wire or cable and position it on the turntable. ( For Romex<sup>®</sup>\*, remove from box and place onto unit. )
2. Locate the end of the cable and pull it through the cable guide.
3. Set the desired drag by adjusting the hex nut at the top of the spring.
4. Prior to first use of 509M mobile unit, assemble handle to frame by inserting handle (Item #17) into frame (Item #12) and secure with hex head cap screw (Item #18) and hex nut (Item #19). See exploded view on Page 4.

## PARTS LIST — Model 509 Cable Dispenser

| ITEM# | PART#    | QTY | DESCRIPTION  |
|-------|----------|-----|--|
| 1     | 509-267A | 1   | REEL STRAP   |
| 2     | 9544-15  | 5   | <sup>5</sup> / <sub>16</sub> -18 X 1" HEX HD SCREW |
| 3     | 509-267B | 1   | REEL STRAP   |
| 4     | 509-3    | 1   | 1"-8 HEX NUT (NYLON INSERT)                        |
| 5     | 509-2    | 1   | SPRING COMPRESSION                                 |
| 6     | 509-271  | 1   | TURN TABLE   |
| 7     | 509-266  | 1   | MOUNTING PLATE                                     |
| 8     | 412-8    | 5   | <sup>5</sup> / <sub>16</sub> -8 HEX NUT            |
| 9     | 412-11   | 5   | <sup>5</sup> / <sub>16</sub> LOCK WASHER           |
| 10    | 509-272  | 1   | CABLE GUIDE  |
| 11    | 509-15   | 1   | WASHER - THRUST                                    |
| 12    | 509-585  | 1   | FRAME  |
| 13    | 509C/M   | 1   | DECAL - MODEL NO. AND CAUTION                      |

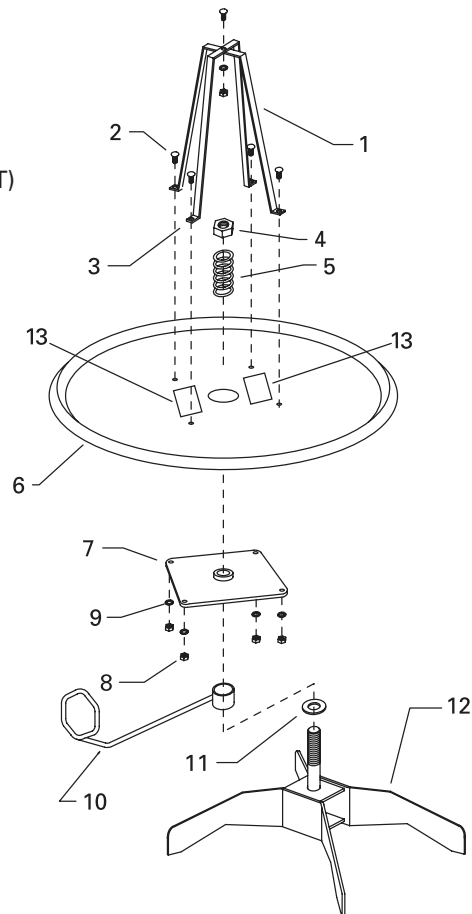

\*Romex is a registered trademark of Southwire Company, LLC.



# PARTS LIST — Model 509M Mobile Cable Dispenser

| ITEM# | PART#    | QTY | DESCRIPTION                              |
|-------|----------|-----|--|
| 1     | 509-267A | 1   | REEL STRAP                               |
| 2     | 9544-15  | 5   | $\frac{5}{16}$ -18 X 1" HEX HD SCREW     |
| 3     | 509-267B | 1   | REEL STRAP                               |
| 4     | 509-3    | 1   | 1"-8 HEX NUT (NYLON INSERT)              |
| 5     | 509-2    | 1   | COMPRESSION SPRING                       |
| 6     | 509-271  | 1   | TURN TABLE                               |
| 7     | 509-266  | 1   | MOUNTING PLATE                           |
| 8     | 412-8    | 5   | $\frac{5}{16}$ -8 HEX NUT                |
| 9     | 412-11   | 5   | $\frac{5}{16}$ LOCK WASHER               |
| 10    | 509-272  | 1   | CABLE GUIDE                              |
| 11    | 509-15   | 1   | THRUST WASHER                            |
| 12    | 509-583  | 1   | FRAME                                    |
| 13    | 509M-C/M | 1   | DECALS – MODEL NO. AND CAUTION           |
| 14*   | 500-001  | 2   | WHEEL                                    |
| 15    | 501-14   | 2   | COTTER PIN                               |
| 16    | 504-1    | 2   | GRIP                                     |
| 17    | 509-582  | 1   | HANDLE                                   |
| 18    | 528-2    | 1   | $\frac{3}{8}$ -16 X 2" HEX HEAD SCREW    |
| 19    | 2-1501-4 | 1   | $\frac{3}{8}$ -16 HEX NUT (NYLON INSERT) |
| 20    | 77-017   | 2   | WASHER – FLAT, $\frac{3}{4}$ "           |

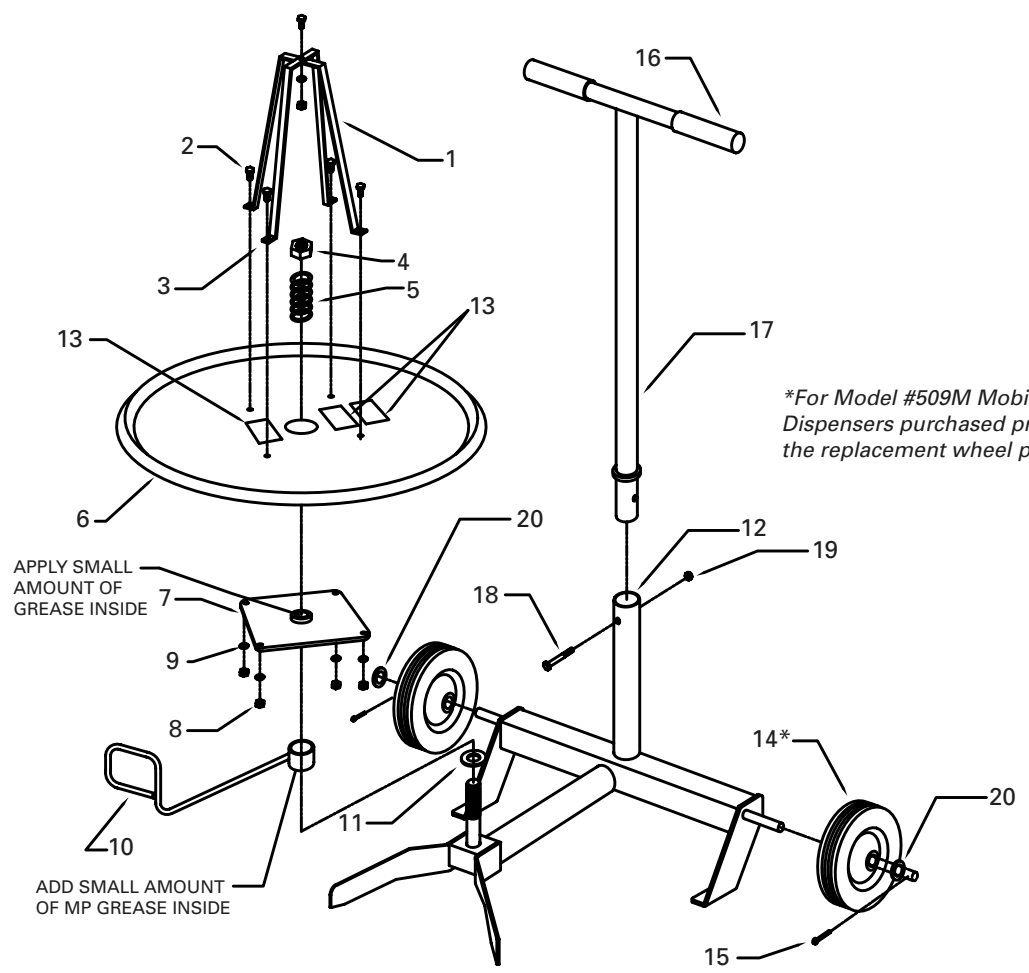

*\*For Model #509M Mobile Cable Dispensers purchased prior to 2022, the replacement wheel part # is 509-13.*