

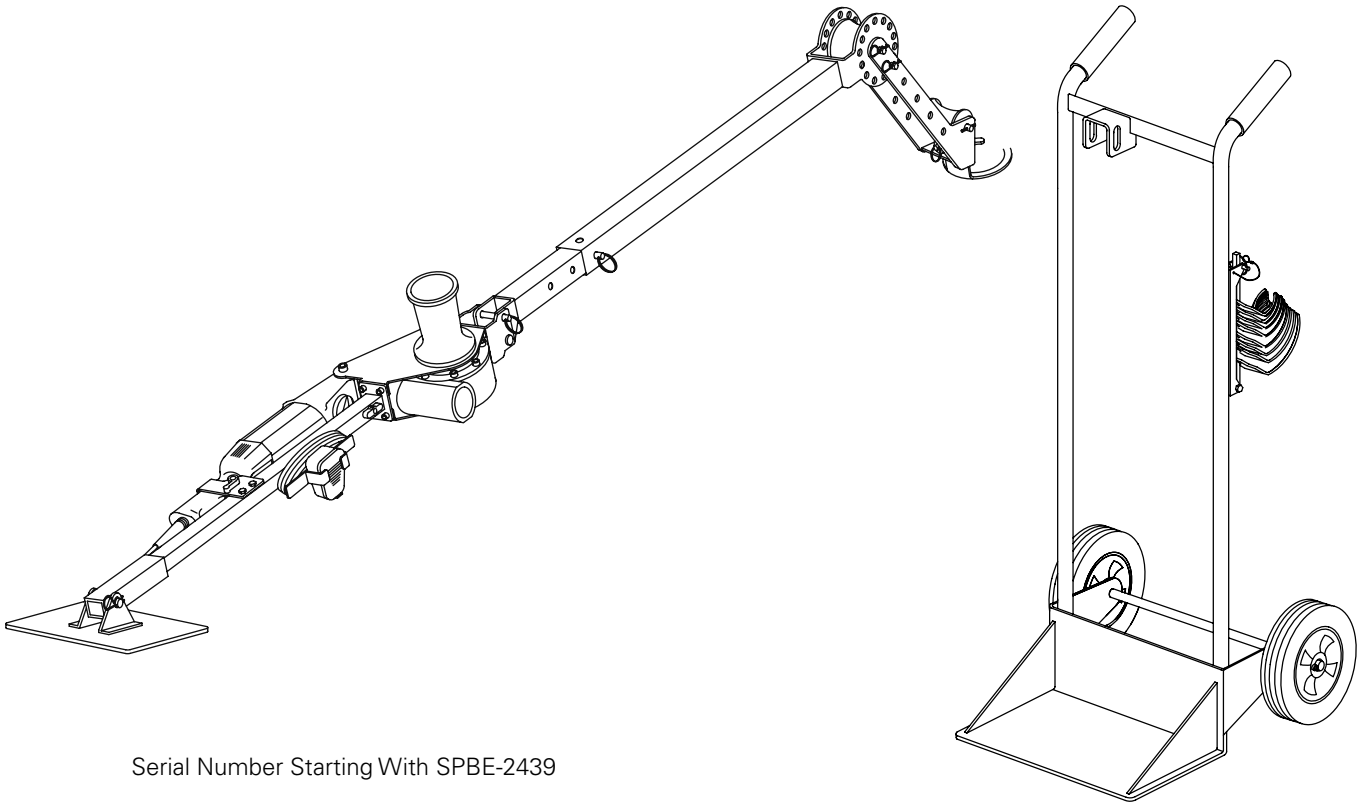

Current Tools

FOR THE PROFESSIONAL ELECTRICIAN

Model 33 High Speed Cable Puller with Mobile Cart



Serial Number Starting With SPBE-2439

Operating, Maintenance, Safety and Parts Manual

03/23



Read and understand this material before operating or servicing the Cable Puller. Failure to understand how to safely operate and service this unit may result in serious injury or death.

This manual is free of charge. All personnel who operate the Cable Puller should have a copy of this manual and read and understand its contents. To request a copy of this manual or replacement safety decals, or for technical assistance, call or write to the address below. All information, specifications and product designs may change due to design improvements or updates and are subject to change without notice. Current Tools does not assume any liability for damages resulting from misuse or incorrect application of its products.

CURRENTTOOLS • P. O. BOX 17026 GREENVILLE, SC 29606
800.230.5421 or 864.721.4230 • FAX 864.721.4232
www.currenttools.com



TABLE OF CONTENTS

<i>Safety Alerts</i>	3
<i>Important Safety Information</i>	4,5
<i>Specifications</i>	6
<i>Features</i>	6
<i>Set-Up and Operating Instructions</i>	7-10
<i>Common Set-Ups</i>	11
<i>Maintenance</i>	12
<i>Exploded View</i>	13,14
<i>Wiring Drawing</i>	14
<i>Parts List</i>	15,16



Safety Alert Symbol

THIS SAFETY SYMBOL is used to call your attention to instructions that concern your personal safety. It means: ATTENTION! BE AWARE! THIS IS AN IMPORTANT SAFETY INSTRUCTION!

Read, understand and follow these safety instructions. Failure to follow these safety instructions may result in injury or death.

DANGER

Immediate hazards which, if not avoided, WILL result in serious personal injury or death.

WARNING

Hazards or unsafe practices which, if not avoided, COULD result in serious personal injury or death.

CAUTION

Hazards or unsafe practices which, if not avoided, COULD result in minor personal injury or property damage.

RETAIN SAFETY INFORMATION



This manual should be read and understood by all personnel who operate or service this Cable Puller. Failure to understand how to safely operate and service this equipment could result in injury or death. This equipment should only be operated and serviced by qualified personnel.



IMPORTANT SAFETY INFORMATION

- ⚠ DANGER** DO NOT operate cable puller in wet or damp locations.
- ⚠ DANGER** DO NOT expose to rain.
- ⚠ DANGER** DO NOT operate in an explosive atmosphere.
- ⚠ DANGER** DO NOT use near energized circuits.
- ⚠ WARNING** DO NOT use cable puller as a hoist or for lifting, supporting or transporting people or loads. Use only for its intended purpose as a cable puller.
- ⚠ WARNING** DO NOT wrap rope around any body parts. DO NOT wrap rope around wrists. Hold rope so that it may be released quickly.
- ⚠ WARNING** ALWAYS keep rope away from operator's feet.
- ⚠ WARNING** DO NOT exceed load rating of cable puller, rope or accessories.
- ⚠ WARNING** ALWAYS inspect rope before each use.
- ⚠ WARNING** ALWAYS disconnect cable puller before servicing.
- ⚠ WARNING** ALWAYS plug the Model 33 Cable Puller into a grounded receptacle with a 15 amp GFCI protected circuit. DO NOT modify the plug provided with the Model 33 Cable Puller.
- ⚠ WARNING** ALWAYS ensure cable puller is properly secured to conduit and all pins are in place before operating.
- ⚠ WARNING** Pulling Rope should be the only thing to contact the capstan. NEVER let swivels, grips, etc. come in contact with the capstan.
- ⚠ WARNING** Rope must ALWAYS be pulled over a rotating sheave. If a sheave does not rotate, turn cable puller off immediately and determine problem before continuing the pull.
- ⚠ WARNING** Set up the cable puller so that pulling rope ALWAYS contacts both rollers. (See drawing below.)

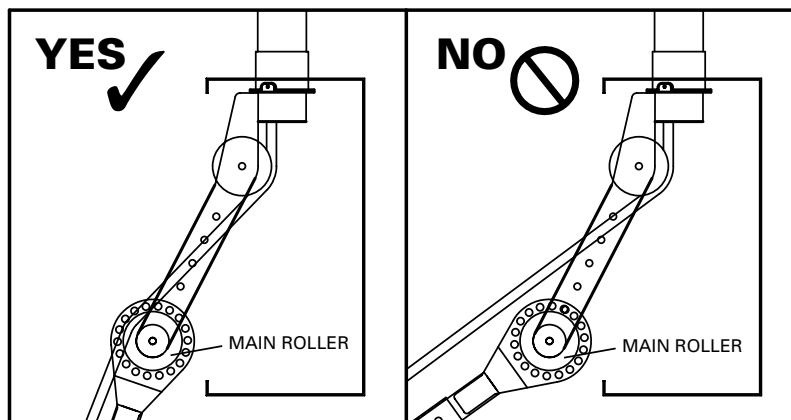

IMPORTANT SAFETY INFORMATION *continued*

▲ WARNING ONLY use $\frac{9}{16}$ " or larger double-braided composite pulling rope or a pulling rope with a minimum average breaking strength of 16,000 lbs.

▲ WARNING NEVER allow the rope to slip on a rotating capstan for more than a couple of seconds. The rope will wear in that spot and the rope could break under pressure.

▲ WARNING Keep all body parts, hair, loose clothing, etc. away from rotating parts and pinch points. Keep hands away from capstan.

▲ WARNING DO NOT allow the rope to overlap on the capstan. If this condition begins to occur, immediately release the tailing force on the rope. If this does not remedy the overlap, stop the puller and run the puller in reverse to unwind the overlap.

▲ WARNING During the pull, all personnel must stand to the side of the cable puller and out of the direct line of tight pulling rope.

▲ WARNING The cable puller must be attached to steel or schedule 40 PVC conduit only. When attached to PVC conduit, the conduit MUST be supported within 2" of the end.

▲ WARNING ALWAYS inspect pins to be sure they are fully inserted through holes and have spring clips properly attached. DO NOT substitute any other object for factory supplied pins.

▲ WARNING When making a vertical cable pull, keep the area underneath the cable pull clear of all personnel.

▲ WARNING Keep fingers away from adjustment holes and pivoting parts. Fingers can be severed by pivoting parts.

▲ CAUTION DO NOT alter this cable puller. Doing so will void the warranty. Guards and safety features are provided for your protection.

▲ CAUTION Wear eye protection when operating the cable puller.

▲ CAUTION Inspect all components of the cable puller before beginning any cable pull. Replace any worn or defective components.

▲ CAUTION Be careful during assembly and disassembly of the cable puller. Have control of components before removing any pins.

▲ CAUTION DO NOT use an extension cord longer than 100 ft. Extension cord should be a minimum of 12 gauge wire with ground.

▲ CAUTION This cable puller exceeds 50 lbs. and will require more than one person to lift or carry.

▲ CAUTION The motor, gear box and capstan may heat up during the pull. Be careful.

▲ CAUTION ALWAYS pull in the direction of the arrows on top of the capstan.

▲ CAUTION Shift speeds ONLY when the capstan is at a stop. DO NOT shift speeds while the capstan is moving

▲ CAUTION Before shifting speeds, release the tailing force on the rope to relieve the tension on the capstan and motor gearbox.

SPECIFICATIONS

model no. — 33 Cable Puller (mounted on Mobile Cart)

width — 21 1/2"

depth — 23"

height — 48"

fully extended length — 104"

weight — 75 lbs. — cable puller only

121 lbs. — cable puller mounted on mobile cart

maximum pulling force — 3,000 lbs.

speeds — no load

Low — 22 ft./min.

High — 84 ft./min.

motor — 120 volts AC, 60 hertz, 13 amps

pulling rope — 9/16" or larger double braided composite pulling rope, or a pulling rope with a minimum breaking strength of 16,000 lbs.

FEATURES

- Integral heavy duty 2 speed motor
- Mounts to mobile cart for storage and ease of mobility
- No disassembly to store cable puller on mobile cart
- Quick release conduit couplings
- Tapered capstan
- Integral foot switch
- Permanently lubricated vent-free gear box
- Light weight — cable puller weighs approximately 75 lbs. (without cart)

SET-UP and OPERATING INSTRUCTIONS



Model 33 Cable Puller shown pinned for transport on mobile cart.



1 Remove the transport pin to release the cable puller from the mobile cart.



2 Unpin the adjustable tube from the hold down bracket as shown. Reinsert the pin in the hold down bracket.

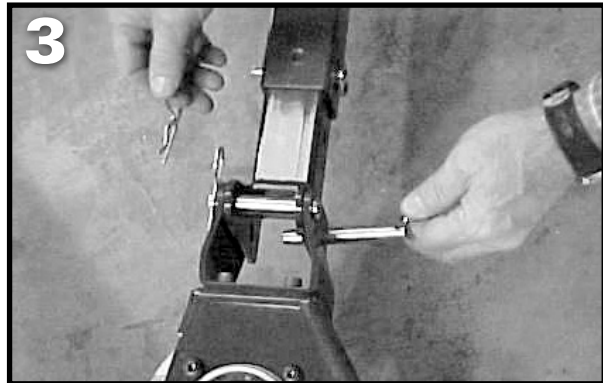

3 Unfold pivot tube and secure into position as shown using transport pin.



4 Cable puller shown unfolded and pinned.

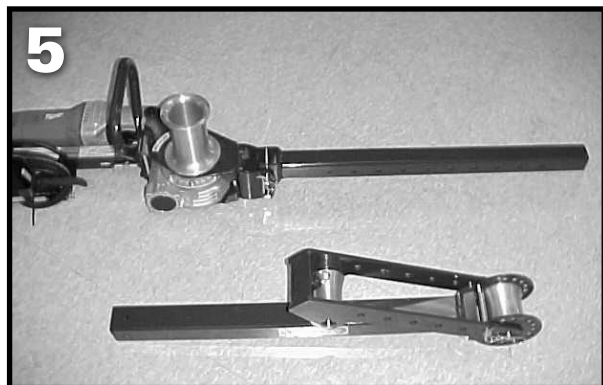

5 In order to set-up the adjustable tube in the correct direction for the pull, unpin and remove the adjustable tube from the pivot tube.

SET-UP AND OPERATING INSTRUCTIONS *continued*



6 Turn the adjustable tube in the direction needed for the type pull (UP, DOWN, SIDE – See **COMMON SET-UPS** on page 11.) and slide back onto the pivot tube to the desired length and re-pin.

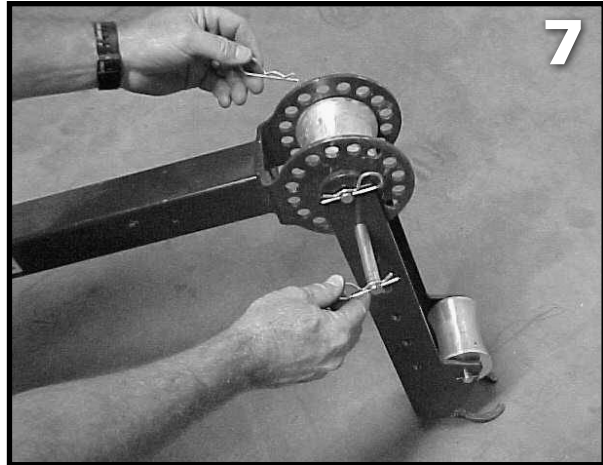

7 Next, to position the extension arm to the desired angle for the pull, remove the pin that allows the extension arm to be adjusted to various positions and re-pin at desired angle. NOTE: If needed, the extension arm length may be adjusted. See close-up photo of side pull in **COMMON SET-UPS** on page 11.

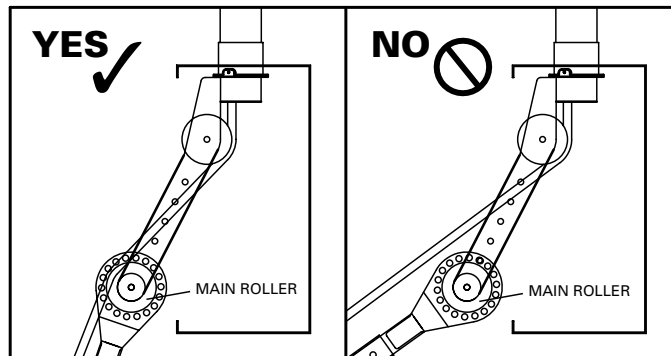

⚠ WARNING Set up the cable puller so that pulling rope ALWAYS contacts both rollers. (See drawing above).



8 Choose the conduit coupling for the size conduit you will be connecting to. Remove the conduit lock nut and place the conduit coupling over the conduit. Then, replace and tighten the conduit lock nut.



The couplings are stored on the mobile cart on a pivoting rod. Remove the lynch pin to lower the rod.

SET-UP AND OPERATING INSTRUCTIONS *continued*



9

9 Next, move the cable puller into position and attach the extension arm onto the conduit coupling. You should hear a "click" as the conduit coupling fits into the extension arm. If extension arm is not at the correct angle to attach to conduit coupling, the angle and/or length of the extension arm may be adjusted. Also, the adjustable tube can be repositioned.

▲ WARNING

Keep fingers away from adjustment mount holes and pivoting parts. Fingers can be severed by pivoting parts.



10

10 Operator may stand on either side of the cable puller. Place the foot switch on the side the operator will be standing. Plug the cord into a 15 amp GFCI protected outlet.

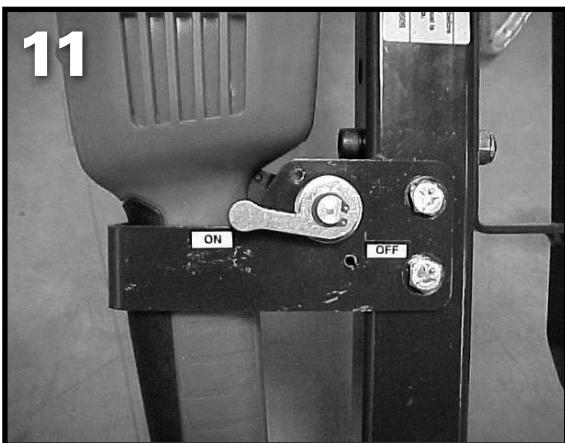

11

11 Turn on/off lever to the "ON" position

12 Turn the FWD/REV switch on motor to the **forward** position. (not shown)

SET-UP AND OPERATING INSTRUCTIONS *continued*



- 13** Depress the foot switch and check the rotation of the capstan with the pulling rotation decal on the cable puller.

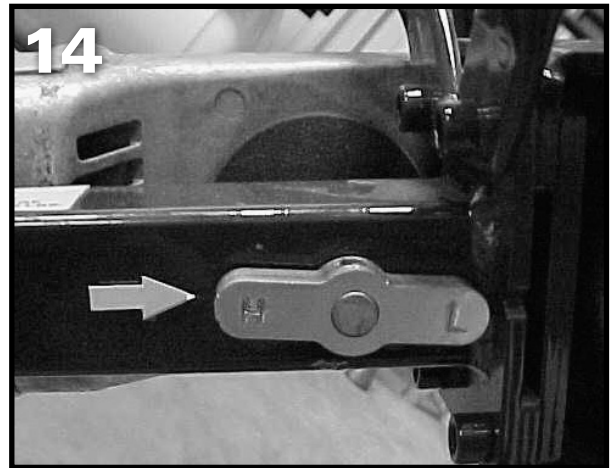

- 14** Next, turn the High/Low speed switch to the desired position, "H" or "L"

NOTE: High speed setting is for lower force pulls. Switch to low speed for higher force pulls or when high speed begins to strain the motor.

CAUTION Shift speeds ONLY when the capstan is at a stop. DO NOT shift speeds while the capstan is moving.

- 15** To begin the pull, place 2 to 3 wraps of the pulling rope around the capstan. Depress the foot switch and begin the pull. If the amount of tension (tailing force) you have to put on the pulling rope exceeds approximately 10 lbs., then turn the cable puller off and add one wrap of the pulling rope. Note that if the rope is in a "v" shape as shown in photo 14, the pull for the operator is easier than if pulled at a 90°. (or "L" shape)



- 16** When the pull is completed, pull the ring on the back of the extension arm to separate the conduit coupling from the extension arm. Loosen the lock nut and remove the conduit coupling.

WARNING NEVER allow the rope to slip on a rotating capstan for more than a couple of seconds. The rope will wear in that spot and the rope could break under pressure.

WARNING DO NOT allow the rope to overlap on the capstan. If this condition begins to occur, immediately release the tailing force on the rope. If this does not remedy the overlap, stop the puller and run the puller in reverse to unwind the overlap.

CAUTION The motor, gear box and capstan may heat up during the pull. Be careful.

COMMON SET-UPS

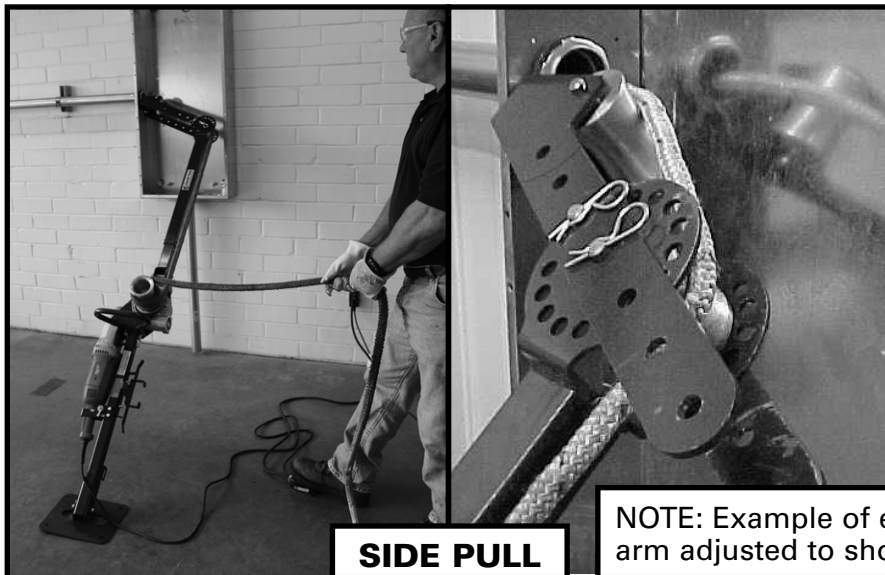
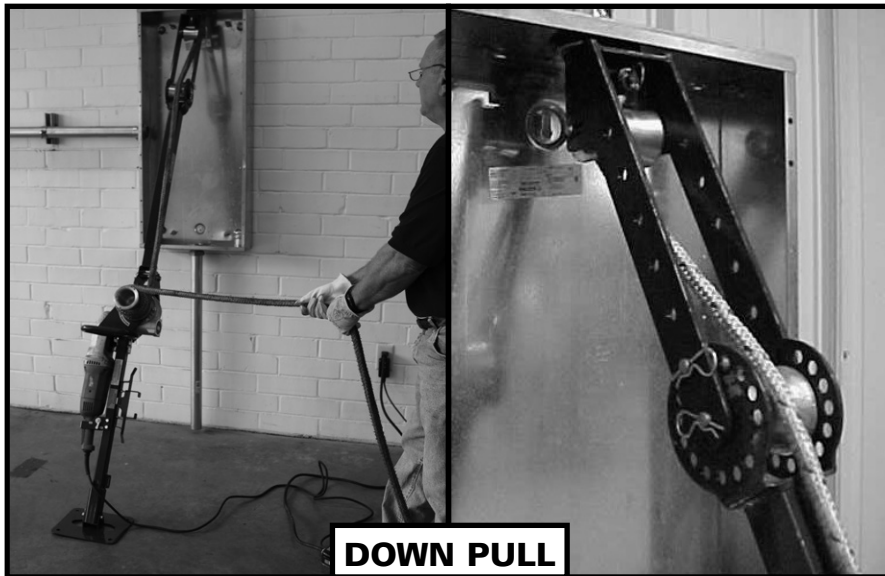
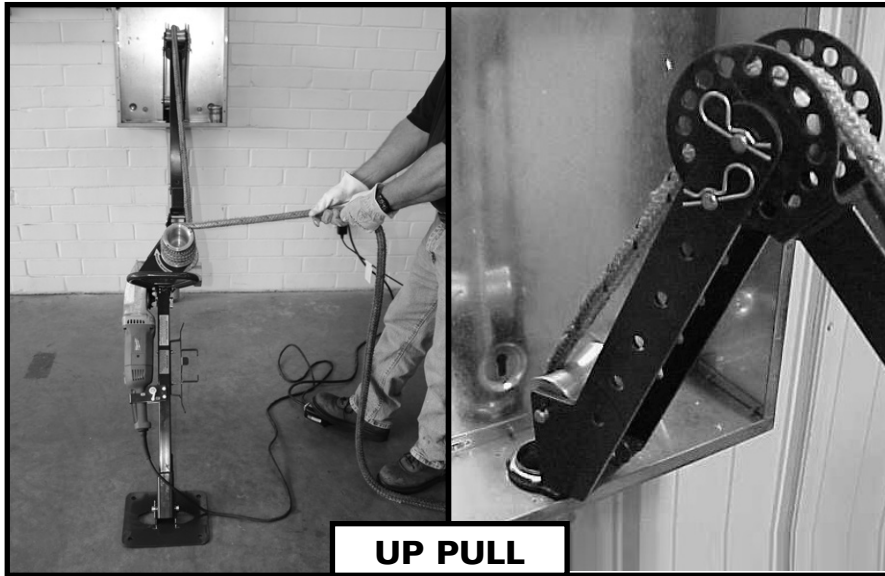

NOTE: Example of extension arm adjusted to shorter length.



WARNING

Unplug the cable puller before servicing.

CAUTION

DO NOT alter this cable puller. Doing so will void the warranty. Guards and safety features are provided for your protection.

Capstan

Replace the capstan if it is grooved more than $\frac{1}{16}$ " deep.

Gear Box

The Model 33 Cable Puller has a vent-free gear box and is factory lubricated for life with synthetic, semi-fluid gear lubricant with an operating range of +5°F to +220°F.

Lubrication

Please refer to Milwaukee Electric Tool Corporation Operator's Manual.

A copy is provided with this cable puller. This cable puller uses a Milwaukee Heavy Duty Super Hawg™ MODEL 1680-20.



EXPLODED VIEW - MODEL 33 CABLE PULLER

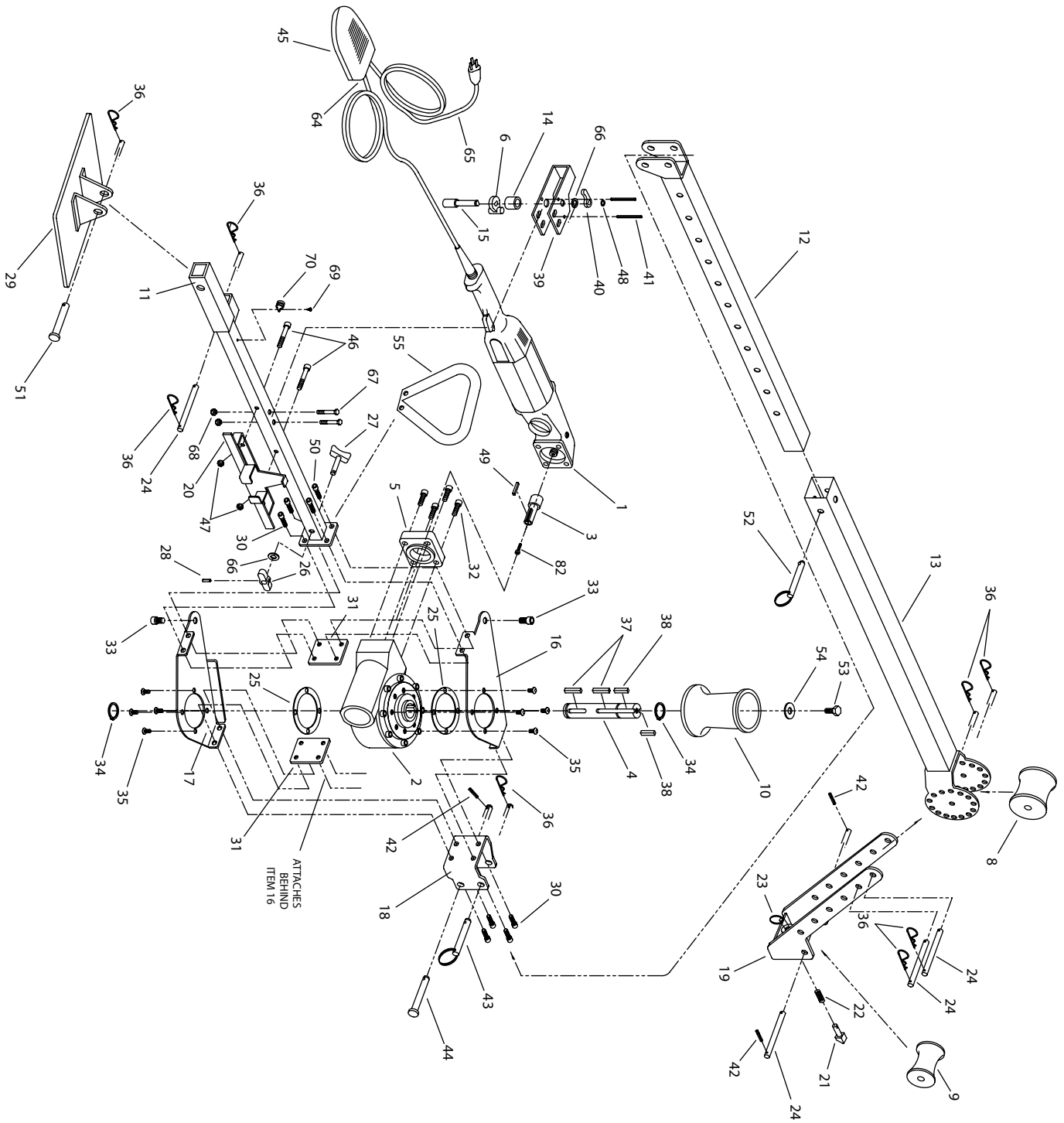

EXPLODED VIEW - MOBILE CART AND COUPLINGS

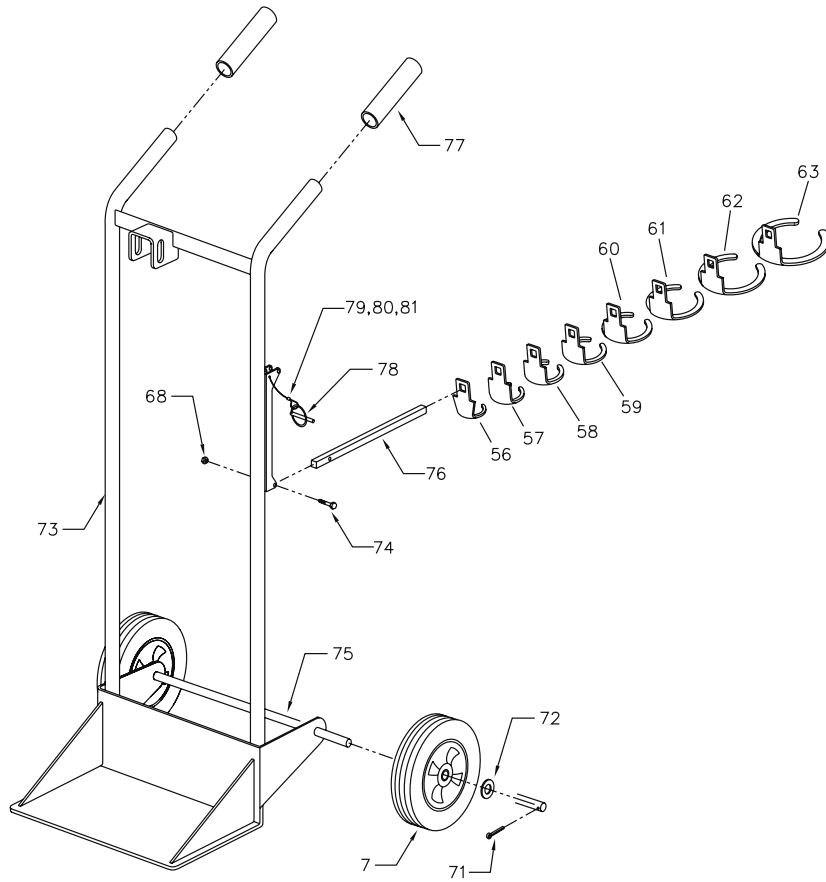

WIRING DRAWING

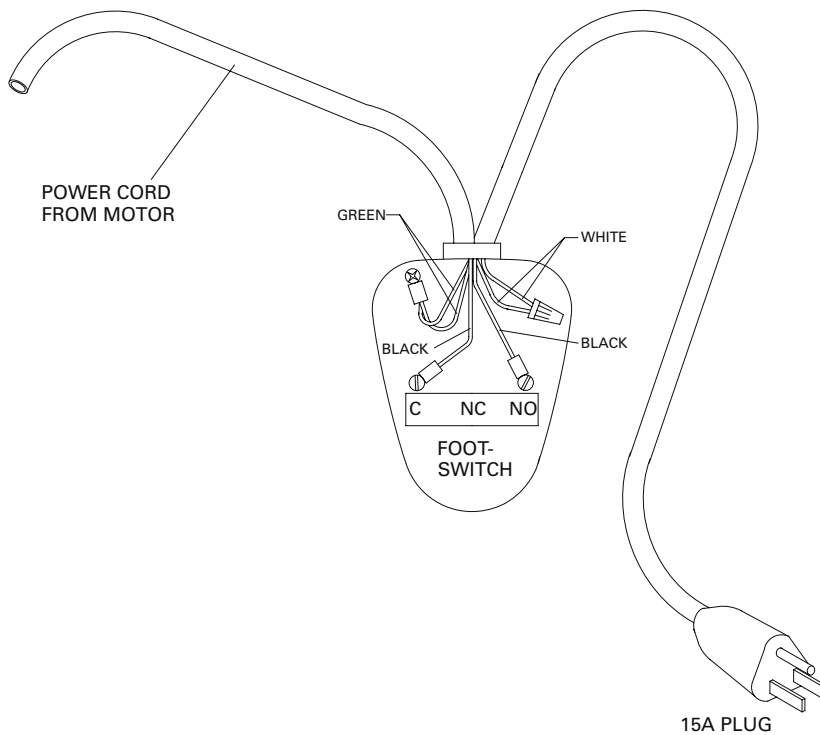



PARTS LIST

Item #	Parts Description	Qty.	Part #
1	MOTOR	1	33 - 1
2	GEAR BOX	1	33 - 2
3	ADAPTER SHAFT	1	33 - 460
4	CAPSTAN SHAFT	1	33 - 462
5	ADAPTER CAP	1	33 - 461
6	CAM-DRILL SWITCH	1	33 - 735
7	WHEEL	2	510 - 2
8	ROLLER - MAIN	1	33 - 683
9	ROLLER - EXTENSION	1	33 - 482
10	CAPSTAN	1	33 - 504
11	DRIVE FRAME	1	33 - 933
12	PIVOTTUBE	1	33 - 531
13	ADJUSTABLETUBE	1	33 - 532
14	SPACER	1	33 - 703
15	BAR-ACTUATOR, SWITCH	1	33 - 702
16	TOP GEAR BOX MOUNTING PLATE	1	33 - 517A
17	BOTTOM GEAR BOX MOUNTING PLATE	1	33 - 517B
18	PIVOT BRACKET	1	33 - 514
19	EXTENSION ARM	1	33 - 533
20	WIRE/FOOT SWITCH HANGER	1	33 - 706
21	PAWL	1	33 - 485
22	SPRING	1	33 - 22
23	RING	1	33 - 23
24	PIN - 1/2" x 4-1/2"	4	33 - 492
25	RING-GEAR BOX PLATE	2	33 - 511
26	HI/LO SWITCH	1	33 - 484
27	HI/LO STEM	1	33 - 682
28	ROLL PIN - SPRING 1/8" X 3/4"	1	77 - 035A
29	BOTTOM PLATE	1	33 - 934
30	SCREW - SOC.HD. CAP - 5/16-18 x 7/8"	6	33 - 30
31	BACK-UP PLATE	2	33 - 510
32	SCREW - SOC. HD. CAP M8 X 25	4	33 - 32
33	SCREW - SOC.HD. CAP - 7/16-14 x 3/4"	2	33 - 33
34	EXT.RETAINING RING	2	88 - 40
35	SCREW - BUTTON SOC. CAP M8 x 20	8	33 - 35
36	R-CLIP	8	33 - 36
37	KEY 1/4"SQ x 1-1/2"	2	33 - 37
38	KEY 1/4"SQ x 1-1/4"	2	8042 - 11
39	BRACKET	1	33 - 700
40	LEVER - ON/OFF	1	33 - 699
41	ROLL PIN - 3/16x1-7/8"	2	33 - 12
42	ROLL PIN - 5/32 x 1"	3	33 - 42
43	PIN - 1/2" x 2-1/2" WITH RING	1	33 - 43
44	PIN - 1/2" x 2-1/2" HEADED W/HOLE	1	33 - 44
45	FOOT SWITCH	1	33 - 45

PARTS LIST *continued*

46	SCREW - SOC.HD. CAP - $\frac{5}{16}$ -18 x 2"	2	33 - 46
47	NUT - $\frac{5}{16}$ -18 NYLON INSERT	2	2-1301-4
48	$\frac{3}{8}$ " RETAINING RING	1	33 - 19
49	KEY $\frac{3}{16}$ "SQ x 1- $\frac{1}{4}$ "	1	33 - 49
50	SCREW - SOC.HD. CAP - $\frac{5}{16}$ -18 x $\frac{3}{4}$ "	2	33 - 50
51	PIN - $\frac{5}{8}$ - CLEVIS	1	33 - 24
52	PIN - QUICK REL. $\frac{3}{8}$ " x 2"	1	9548 - 7
53	SCREW - HEX HD. CAP - $\frac{3}{8}$ -16 x $\frac{3}{4}$ "	1	33 - 53
54	FLAT WASHER - $\frac{3}{8}$ "	1	33 - 54
55	STAND	1	33 - 491
56	CONDUIT COUPLING - 1"	1	33 - 520
57	CONDUIT COUPLING - 1- $\frac{1}{4}$ "	1	33 - 534
58	CONDUIT COUPLING - 1- $\frac{1}{2}$ "	1	33 - 522
59	CONDUIT COUPLING - 2"	1	33 - 523
60	CONDUIT COUPLING - 2- $\frac{1}{2}$ "	1	33 - 524
61	CONDUIT COUPLING - 3"	1	33 - 525
62	CONDUIT COUPLING - 3- $\frac{1}{2}$ "	1	33 - 526
63	CONDUIT COUPLING - 4"	1	33 - 527
64	STRAIN RELIEF	1	450 - 18
65	POWER CORD	1	450 - 4
66	WASHER - $\frac{3}{8}$ "	1	33 - 52
67	SCREW - HEX HD. CAP - $\frac{1}{4}$ -20 x 2- $\frac{1}{4}$ "	2	33 - 21
68	NUT - HEX $\frac{1}{4}$ -20 (NYLON INSERT)	3	9518SR - 12
69	SCREW - HEX HEAD 10 x $\frac{1}{2}$ SELF DRILL	1	77 - 033A
70	CORD RETAINER	1	66 - 62
71	COTTER PIN - $\frac{3}{16}$ x 1 $\frac{1}{4}$	2	501-14
72	WASHER - $\frac{3}{4}$ SAE	2	77-017
73	CART	1	33-966
74	SCREW - PAN PHILLIPS, $\frac{1}{4}$ "-20 x 1 $\frac{1}{4}$	1	450-29
75	AXLE	1	33-967
76	BAR-COUPLING HOLDER	1	33-908
77	GRIP	2	504-1
78	PIN LINCH	1	33-78
79	STOP CABLE	1	670-6A
80	FERRULE CABLE	1	670-6
81	$\frac{1}{16}$ STEEL CABLE	1	33-27
82	SCREW	1	33-460 SCREW