



Current Tools

FOR THE PROFESSIONAL ELECTRICIAN

Current Tools™ 77 Series Electric Bender with Single Shoe Groups

**for bending 1/2" thru 2" RIGID - EMT - IMC
PVC Coated Rigid and Aluminum EMT conduit**

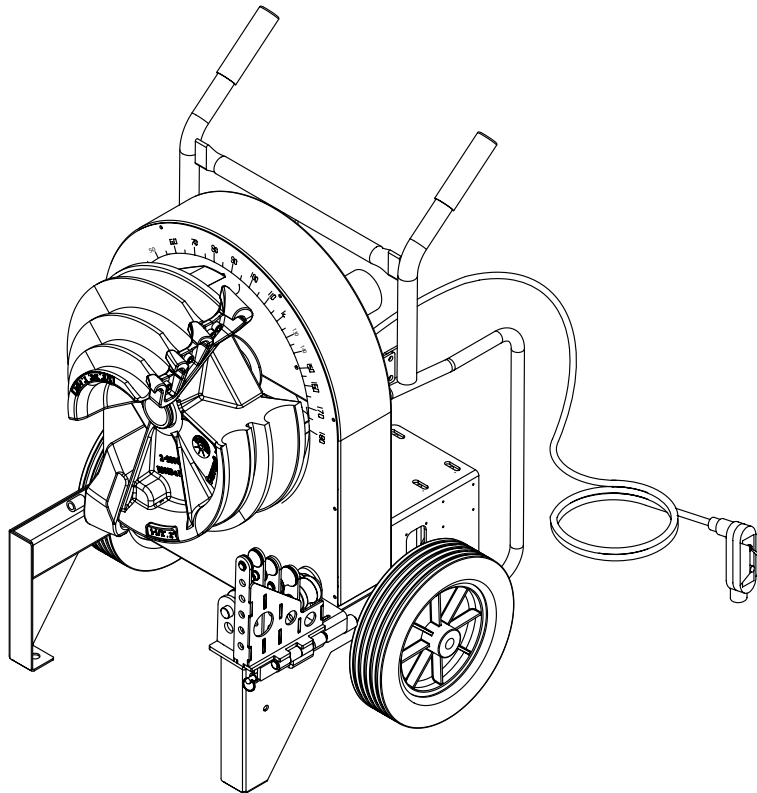

**LISTED
CONDUIT BENDER**



Operating, Maintenance, Safety and Parts Manual

01/24



Read and understand this material before operating or servicing this Bender. Failure to understand how to safely operate and service this unit may result in serious injury or death.

This manual is free of charge. All personnel who operate this Bender should have a copy of this manual and read and understand its contents. To request a copy, call or write to the address below. All information, specifications and product designs may change due to design improvements or updates and are subject to change without notice. Current Tools does not assume any liability for damages resulting from misuse or incorrect application of its products.

**CURRENTTOOLS • P. O. BOX 17026 GREENVILLE, SC 29606
800.230.5421 or 864.721.4230 • FAX 864.721.4232
www.currenttools.com**



TABLE OF CONTENTS

Safety Alerts	3
Important Safety Information	4, 5
Specifications – 77 Series Electric Bender	6
Model Descriptions	6
Features	6, 7
Shoe Groups	8
Conduit Centerline Bending Radii	8
Grounding Instructions	9
Mounting Roller Support	10
Mounting Bending Shoe	11
General Bending Instructions	12, 13
Bending Instructions for 1 1/2" and 2" EMT & IMC Conduit	14-16
Squeeze Adjustment Procedure for 1 1/2" and 2" EMT & IMC Roller Supports	17
Bending Instructions for 1/2" to 1" Aluminum EMT	18
Bending Instructions for 1 1/4" and 2" Aluminum EMT	19
Bending Instructions for 1 1/2" and 2" Aluminum EMT	20
Maintenance	21, 22
Stub-Up Bending Information and Charts	23, 24
Offset Bending Information and Charts	25, 26
Troubleshooting	27
Exploded Views	28, 29
Parts List	30, 31
Electrical System Diagram	32
Parts List – Bending Shoes & Roller Supports	33-42



Safety Alert Symbol

THIS SAFETY SYMBOL is used to call your attention to instructions that concern your personal safety. It means: ATTENTION! BE AWARE! THIS IS AN IMPORTANT SAFETY INSTRUCTION!

Read, understand, and follow these safety instructions. Failure to follow these safety instructions may result in injury or death.

DANGER

Immediate hazards which, if not avoided, **WILL** result in serious personal injury or death.

WARNING

Hazards or unsafe practices which, if not avoided, **COULD** result in serious personal injury or death.

CAUTION

Hazards or unsafe practices which, if not avoided, **COULD** result in minor personal injury or property damage.

RETAIN SAFETY INFORMATION



This manual should be read and understood by all personnel who operate or service this bender. Failure to understand how to safely operate and service this unit could result in injury or death. This unit should only be operated and serviced by qualified personnel.



IMPORTANT SAFETY INFORMATION

⚠ DANGER

NEVER operate the bender in an explosive atmosphere.

⚠ WARNING

NEVER operate the bender in wet or damp locations. DO NOT expose the bender to rain.

⚠ WARNING

ALWAYS use 120 VAC, 20 AMP ground fault protected receptacle for power supply that is properly installed and meets all applicable electrical codes. See grounding instructions on page 9.

⚠ WARNING

ALWAYS inspect power cord before using bender. Replace damaged or worn cords.

⚠ WARNING

ALWAYS disconnect bender before servicing.

⚠ WARNING

ALWAYS make sure the circuit breaker switch is in the off position before plugging in. This will reduce the risk of unintentional starting.

⚠ WARNING

DO NOT modify the plug provided with the bender.

⚠ WARNING

ALWAYS use 12-gauge extension cords that have three prong grounding type plugs and three-hole receptacles that accept the bender's plug. DO NOT use an adapter.

⚠ WARNING

NEVER use an extension cord longer than 100 feet.

⚠ WARNING

ALWAYS replace damaged extension cords.

⚠ WARNING

ALWAYS disconnect the bender before servicing or changing shoes, attachments or roller supports, and when not in use.

⚠ WARNING

ALWAYS inspect the bender before operating. Replace any damaged, missing or worn parts.

⚠ WARNING

NEVER alter this equipment. Doing so will void the warranty.

⚠ WARNING

NEVER remove guards, they are installed for your protection.

⚠ WARNING

ALWAYS check for damaged or worn parts. Check for alignment of moving parts, binding of moving parts, breakage of parts, mounting and any other conditions that may affect its operation. A guard or other part that is damaged should be properly repaired or replaced.



IMPORTANT SAFETY INFORMATION – *continued*

- ▲ WARNING** ALWAYS use recommended accessories. Consult this manual for recommended accessories. The use of improper accessories may cause risk of injury.
- ▲ WARNING** ALWAYS keep hands and feet away from pinch points such as bending shoes, roller supports and conduit when bender is in use.
- ▲ WARNING** Operator must ALWAYS face the front of the bender with the bending degree scale visible and maintain a minimum of 3 feet distance while the conduit is being bent. All other personnel must remain out of the area while the bender is in operation.
- ▲ WARNING** ALWAYS use appropriate shoe groove and roller support for the type and size conduit to be bent.
- ▲ WARNING** If bending shoe will not turn, STOP unit and unplug before checking for any obstructions.
- ▲ WARNING** DO NOT use bender or attachments to do a job for which it was not designed.
- ▲ WARNING** ALWAYS keep conduit under control when unloading.
- ▲ WARNING** ALWAYS keep the path of the bending conduit clear of obstructions. Make sure all obstacles are clear of the bending path BEFORE you bend the conduit.
- ▲ WARNING** Be sure handle is bolted securely to the bender frame before moving or lifting the bender.
- ▲ WARNING** NEVER stand on bender. Serious injury could occur if the bender is tipped or if the bending shoe is unintentionally contacted.
- ▲ WARNING** ALWAYS wear approved safety glasses when the bender is in operation.
- ▲ WARNING** ALWAYS wear proper apparel. Do not wear loose clothing, gloves, neckties, rings, bracelets, or other jewelry which may get caught in moving parts. Non-slip footwear is recommended. Wear protective hair covering to contain long hair.
- ▲ WARNING** ALWAYS keep children away. All visitors should be kept a safe distance from work area.
- ▲ WARNING** ALWAYS make bender childproof with lockouts, master switches or by unplugging unit.
- ▲ CAUTION** The bender and some accessories exceed 50 lbs. and will require more than one person to lift, transport and assemble.
- ▲ CAUTION** Only use the bender for its intended purpose as specified in this manual.
- ▲ CAUTION** ALWAYS use this bender in a dry, well lighted area.
- ▲ CAUTION** ALWAYS maintain bender with care. Keep bender clean for best and safest performance.

SPECIFICATIONS - 77 SERIES ELECTRIC BENDER WITH SINGLE SHOE GROUPS

1/2" thru 2" RIGID conduit
 1/2" thru 2" EMT conduit
 1/2" thru 2" IMC conduit
 1/2" thru 2" 40 mil PVC coated RIGID conduit
 1/2" thru 2" schedule 40 steel pipe
 1/2" thru 2" aluminum EMT

No modification to the 77 POWER UNIT is required to accommodate these shoes or roller supports.
No tools are required to install or remove these shoes and roller supports.

The 77 Series Electric Bender is **NOT** to be used for bending any conduit or pipe wall thickness above schedule 40 pipe.

width	29 1/2"
length	24 3/4"
height	39"
weight	256 lbs. Power Unit Only - <i>without shoes</i>

MODEL DESCRIPTIONS

77	Electric Bender Power Unit only, without shoes and roller supports
77SR	Electric Bender with shoe and roller support for 1/2" thru 2" RIGID conduit and schedule 40 pipe and 1/2" thru 1 1/4" IMC conduit
77SE	Electric Bender with shoe and roller support for 1/2" thru 2" EMT conduit
77SI	Electric Bender with shoe and roller support for 1/2" thru 2" IMC conduit
77SP	Electric Bender with shoe and roller support for 1/2" thru 2" PVC coated RIGID conduit
77SAE	Electric Bender with shoe and roller supports for 1/2" thru 2" aluminum EMT

FEATURES

- Bending Degree Scale** - easy to read for exact bends.
- Roller Supports** - for supporting the conduit during bending.
- Hinge Pin** - for securing the roller supports.
- 12 inch Wheels** - for easy mobility.
- D.C. Motor** - quiet and strong.
- Bending Instructions Decal** - easy to read for quick reference.
- Remote Pendant** - with 6 foot cord.
(Bend and unload from pendant.)
- Removable Handle** - may be removed for dog-leg bends
- Back Rails** - Protect the back of bender and enable the bender to be used horizontally

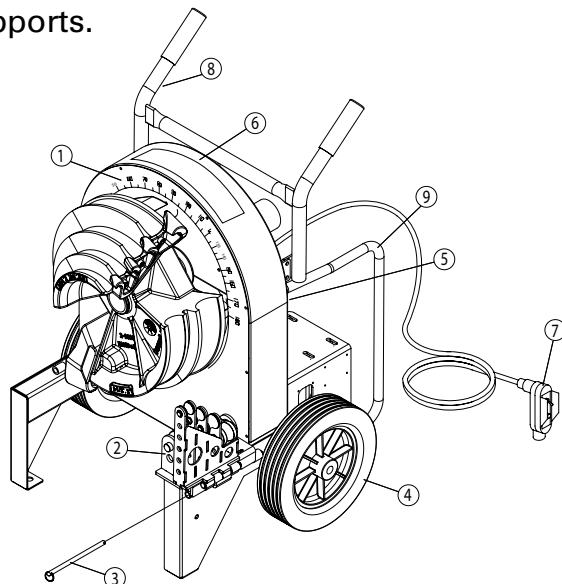

Special Features

The 77 Series Electric Benders have a unique feature to remove the handles during a "Dog-Leg Bend." See Figure 7a below.

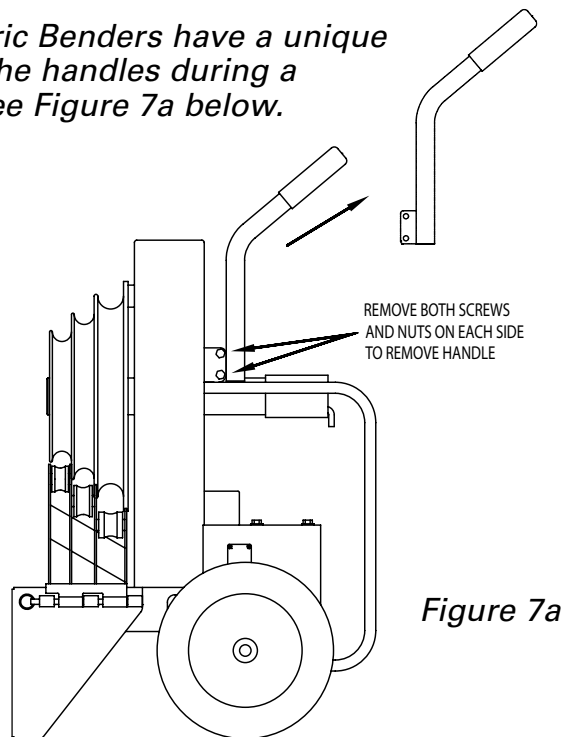

Figure 7a

! WARNING

When replacing handle, be sure to replace screws and nuts and also to tighten securely before moving or transporting.

The 77 Series Electric Benders may also be used in a horizontal position. The bender can operate in this position as efficiently as it does in the upright position. See Figure 7b below.

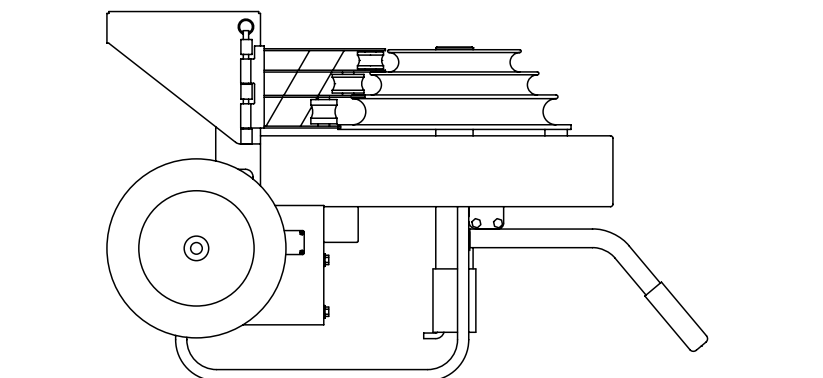
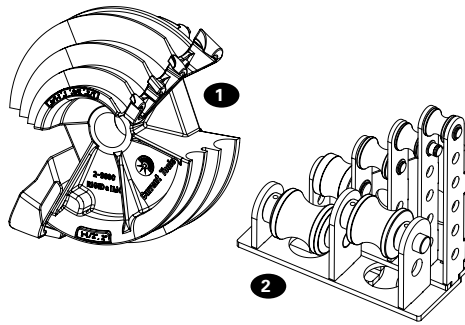

Figure 7b

SINGLE SHOE GROUPS

RIGID



700SR - for bending 1/2" thru 2" RIGID conduit, 1/2" thru 1 1/4" IMC conduit and 1/2" thru 2" schedule 40 pipe includes the following items.

Key	Catalog#	Description
1	2-3000	1/2" thru 2" bending shoe
2	2-4000	1/2" thru 2" roller support
3	8-0501	Storage box (not shown)

IMC

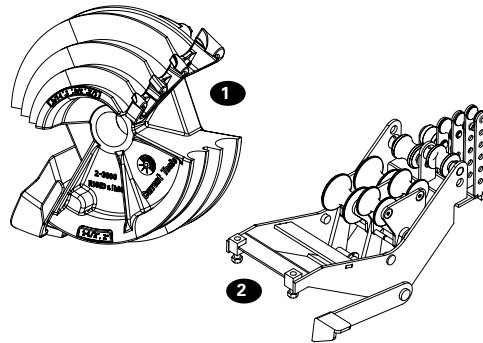

700SI - for bending 1/2" thru 2" IMC conduit includes the following items.

Key	Catalog#	Description
1	2-3000	1/2" thru 2" bending shoe
2	2-4100	1/2" thru 2" roller support
3	8-0501	storage box (not shown)

EMT

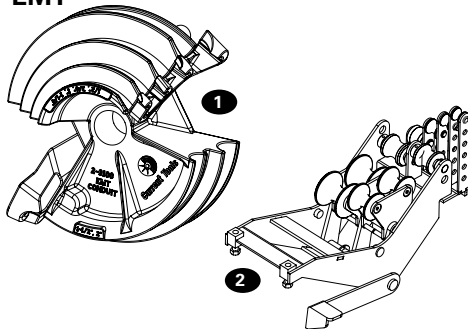

700SE - for bending 1/2" thru 2" EMT (Thinwall) includes the following items.

Key	Catalog#	Description
1	2-3100	1/2" thru 2" bending shoe
2	2-4200	1/2" thru 2" roller support
3	8-0501	storage box (not shown)

PVC COATED RIGID

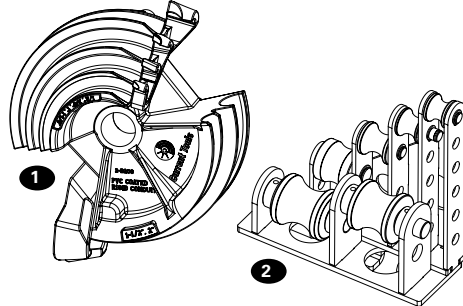

700SP - for bending 1/2" thru 2" 40 mil PVC coated RIGID includes the following items.

Key	Catalog	Description
1	2-3200	1/2" thru 2" bending shoe
2	2-4300	1/2" thru 2" roller support
3	8-0501	storage box (not shown)

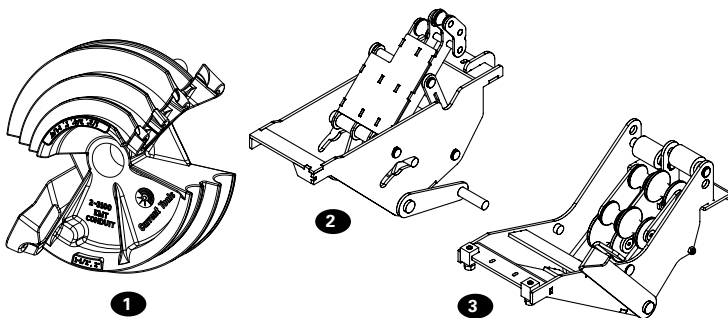

ALUMINUM EMT

700SAE - for bending 1/2" thru 2" aluminum EMT conduit includes the following items.

Key	Catalog	Description
1	2-3100	1/2" thru 2" bending shoe
2	2-4400	1/2" thru 1" roller support
3	2-4500	1 1/4" thru 2" roller support

CONDUIT CENTERLINE BENDING RADII

size	1/2"	3/4"	1"	1 1/4"	1 1/2"	2"
EMT	4-5/16	5-1/2	7	8-13/16	8-3/8	9-1/4
IMC	4-1/4	5-7/16	6-15/16	8-3/4	8-1/4	9
RIGID	4-1/4	5-7/16	6-15/16	8-3/4	8-1/4	9
PVC COATED RIGID	4-1/4	5-7/16	6-15/16	8-3/4	8-1/4	9
ALUMINUM EMT	4-5/16	5-1/2	7	8-13/16	8-3/8	9-1/4

GROUNDING INSTRUCTIONS

WARNING

ELECTRIC SHOCK HAZARD! Only connect the bender to a 20 AMP GFCI protected circuit. **DO NOT** modify the plug which is provided with the unit. Failure to follow these warnings can result in serious injury or death.

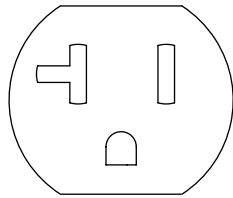

RECEPTACLE

Figure 9a

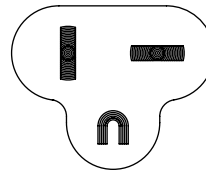

PLUG

Figure 9b

In the event of a malfunction or breakdown, grounding provides a path of least resistance for electric current to reduce the risk of electric shock. The bender is equipped with an electric cord having an equipment grounding conductor and a grounding plug. Only connect the bender to a 20 AMP GFCI protected receptacle which is properly installed and grounded to meet all applicable electrical codes. Do NOT use an adapter.

Do NOT modify the plug provided. If it will not fit the receptacle, have the proper receptacle installed by a qualified electrician.

Improper connection of the equipment grounding conductor can result in risk of electric shock. The conductor with insulation having an outer surface that is green with or without yellow stripes is the equipment grounding conductor. If repair or replacement of the electric cord or plug is necessary, do not connect the equipment grounding conductor to a live terminal.

Check with a qualified electrician or service personnel if the grounding instructions are not completely understood, or if in doubt as to whether the bender is properly grounded.

Use only 3-wire extension cords that have 3-prong grounding plugs and 3-pole receptacles that accept the bender's plug.

Repair or replace damaged or worn cord immediately.

This bender is intended for use on a circuit that has a receptacle that looks like the one illustrated in Figure 9a above. The bender has a grounding plug that looks like the plug illustrated in Figure 9b above.

MOUNTING ROLLER SUPPORT

Choose the correct roller support for the type of conduit you will be bending (RIGID, IMC, EMT, PVC coated rigid or aluminum EMT). The appropriate size and type of roller support **MUST** be used with the corresponding shoe size and type.

Mount the roller support on the bender. Secure the roller support with the quick release hinge pin. See Figures 10a.

NOTE: Rigid and IMC conduit are bent on the same shoe. However, the roller supports are specific for Rigid or IMC.

NOTE: EMT and aluminum EMT conduit are bent on the same shoe. However, the roller supports are specific for EMT or aluminum EMT.

Aluminum EMT uses two roller supports to bend 1/2" to 2". Part #2-4400 for 1/2" to 1" and part #2-4500 for 1 1/4" to 2".

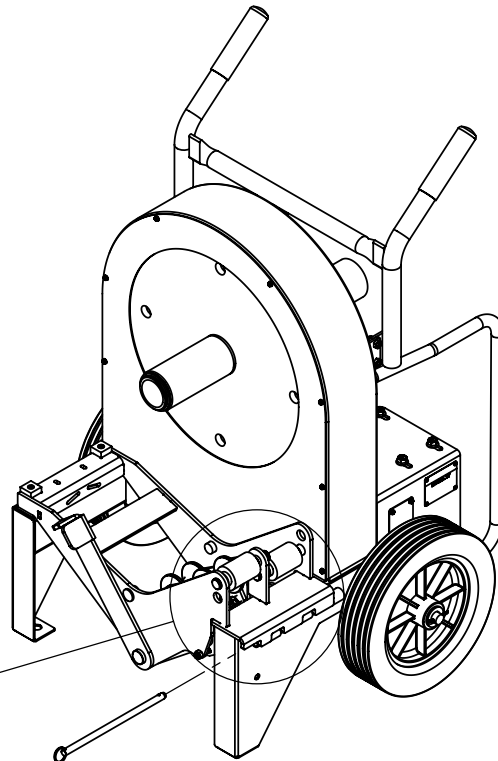

Bender shown with 1 1/4" to 2" Aluminum EMT Roller Support

Figure 10a

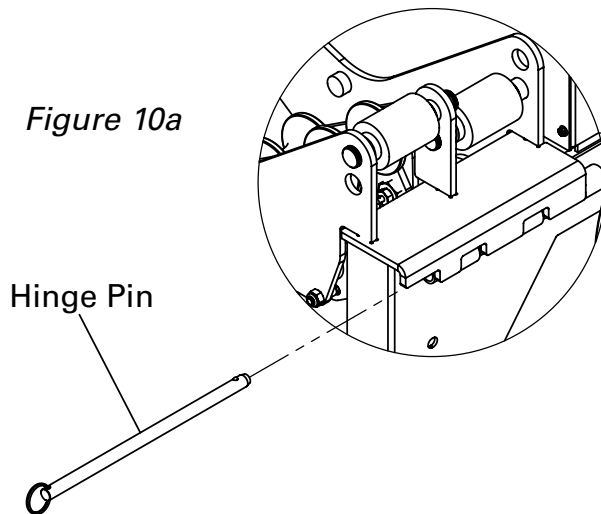

Hinge Pin

MOUNTING INSTRUCTIONS FOR GREENLEE® SHOES AND ATTACHMENTS

Most bending shoes and attachments for the Greenlee® 555® and 555 Classic® will fit the Model #77 Bender. In addition, most bending shoes and attachments for the Model #77 Bender will fit the Greenlee® 555® and 555 Classic® bender.

Contact Current Tools for specific applications and compatibility.

* Greenlee® 555® and 555 Classic® are registered trademarks of Greenlee/Textron.

MOUNTING BENDING SHOE

Choose the correct bending shoe for the type conduit you will be bending (RIGID, IMC, EMT, PVC coated RIGID or aluminum EMT) and slide shoe onto the main drive sprocket shaft. See Figure 11a.

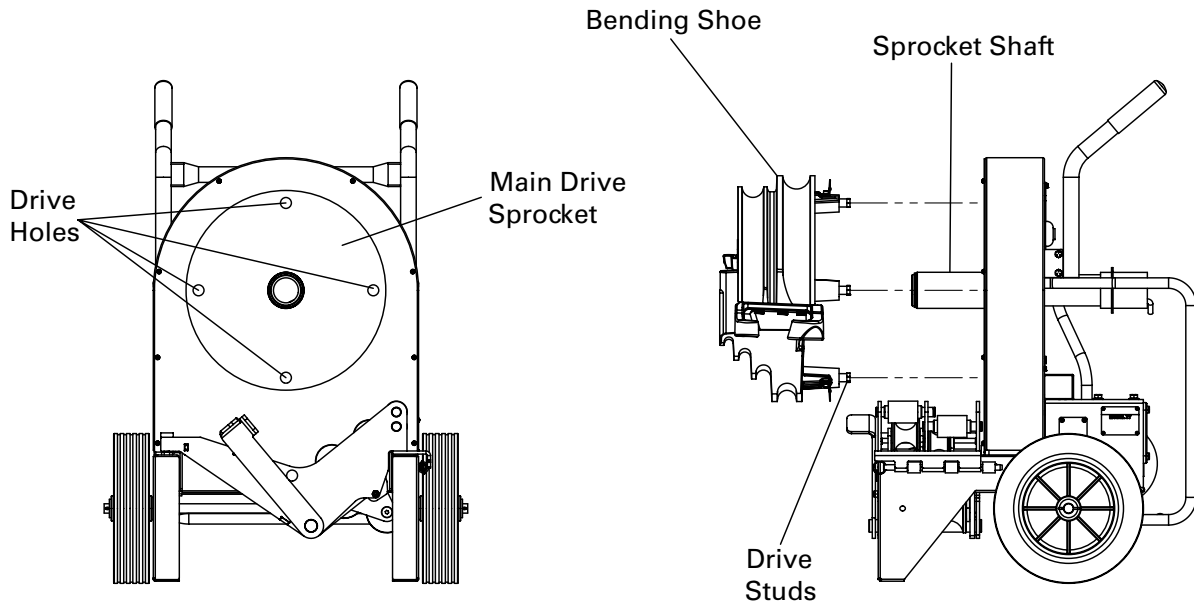

Figure 11a

Next, align the four drive studs on the back of the shoe with the four drive holes in the main drive sprocket.

Push the shoe onto the main drive sprocket shaft. See Figure 11a.

NOTE: ALWAYS remove the bending shoe BEFORE adjusting the rollers for 1 1/4" to 2" Aluminum EMT conduit.



GENERAL BENDING INSTRUCTIONS

Bending instructions for:

- 1/2" thru 2" RIGID conduit**
- 1/2" thru 1 1/4" EMT conduit**
- 1/2" thru 1 1/4" IMC conduit**
- 1/2" thru 2" 40 mil PVC coated RIGID conduit**
- 1/2" thru 2" schedule 40 pipe**
- 1/2" thru 2" aluminum EMT**

See pages 10 and 11 for mounting shoe and roller support.

Be sure to match the appropriate shoe with its corresponding roller support.

1. Mark pipe/conduit to the desired length. Note that a 2" minimum distance from the end of the conduit to the bending mark is required to eliminate flattening the end of the pipe/conduit. See Figure 12.

NOTE: Stub-up and Offset dimensions can be found on the bending charts on pages 23 thru 26 of this manual or on the bending instruction decal on top of each bender.

2. Rotate the bending shoe to 10 degrees below the 0 (zero) degree setting, as shown in Figure 12 below.



DANGER

NEVER operate this bender in an explosive atmosphere. Injury or Death may occur.

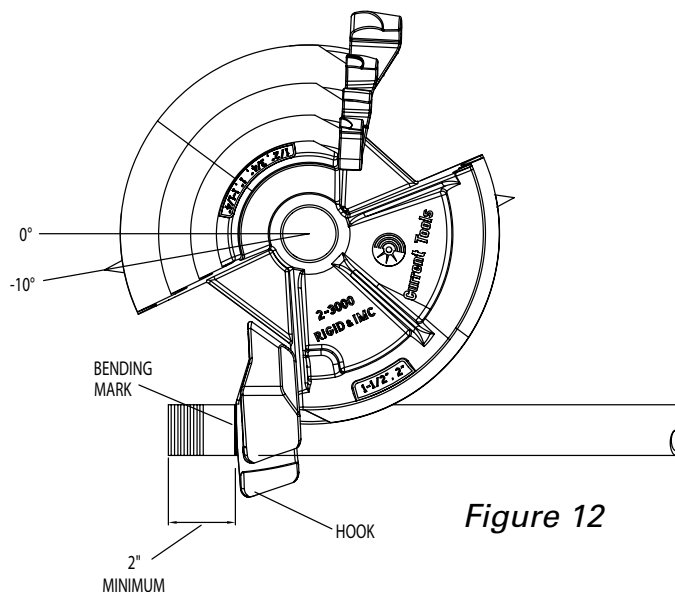

Figure 12



GENERAL BENDING INSTRUCTIONS – *continued*

3. After marking the pipe/conduit, place it into the bender. See Figure 12. The pipe/conduit should slide over the correct size roller support, through the shoe groove and into the hook. The bending mark should be at the front (OUTSIDE) edge of the hook. See Figure 12.
4. Using the remote pendant, place the "Bend/Unload" switch in the "bend" position. Press the "Jog" button and advance the bender shoe. Be sure to check the alignment of the bending mark as the rotating shoe locks the pipe/conduit into position. Advance the bender shoe to the desired degree of bend. When the arrow on the shoe reaches the desired degree of bend, release the "Jog" button and the bender will stop.

NOTE: Due to springback in pipe/conduit, some over bending is necessary to achieve the desired degree of bend. See page 24 or the bending instruction decal on top of each bender for approximate springback compensation figures.

5. To release the pipe/conduit, place the "Bend/Unload" switch in the "Unload" position. Press the "Jog" button and reverse the shoe far enough to release the conduit. Then, rotate the roller support out of the way. See Figure 13a & 13b. The pipe/conduit can now be removed.

WARNING

The pipe/conduit should be under control when unloading. Failure to do this may result in injury or death.

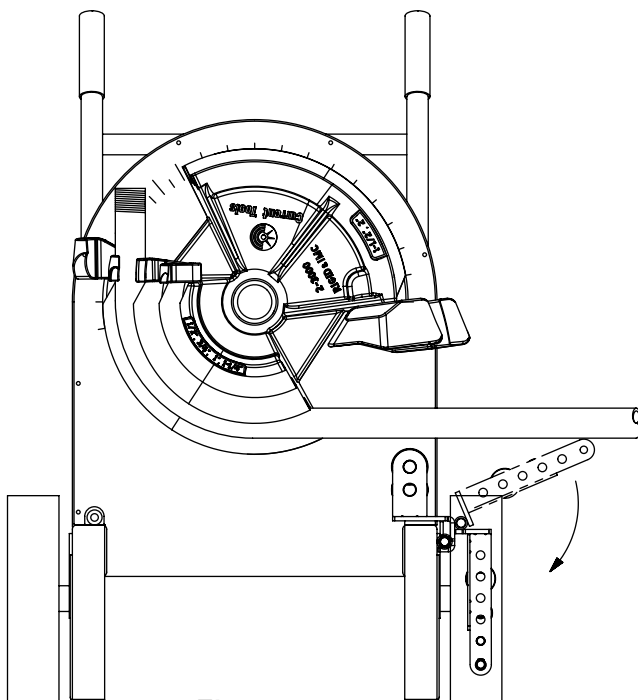

Figure 13a
Bender shown with
1/2" to 2" Rigid roller support

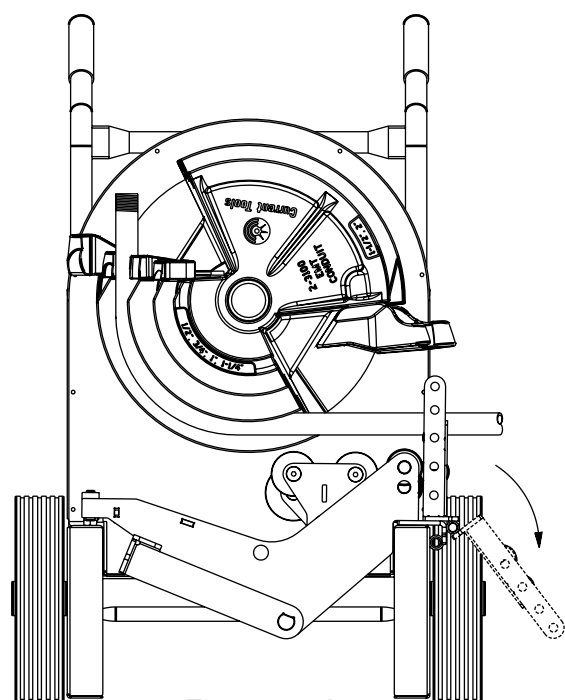

Figure 13b
Bender shown with
1/2" to 2" EMT roller support



BENDING INSTRUCTIONS FOR 1 1/2" AND 2" EMT & IMC CONDUIT

1. See pages 10 and 11 for mounting shoe and roller support.
Be sure to match the appropriate shoe with its corresponding roller support.

NOTE: The frame color of the EMT roller support is silver (see Figure 14a).
The frame color of the IMC roller support is yellow (see Figure 14b).

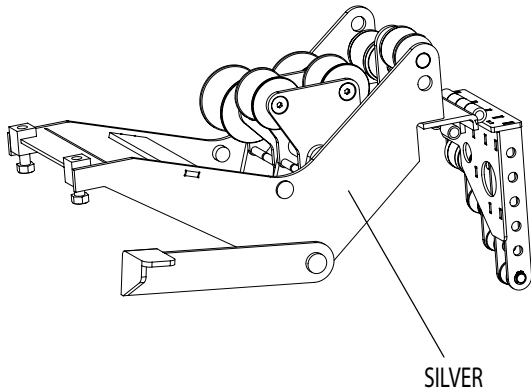

EMT ROLLER SUPPORT

Figure 14a

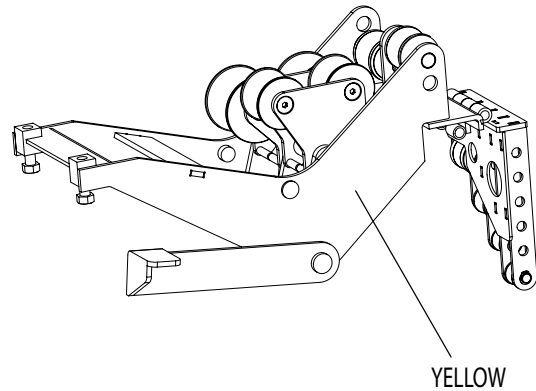

IMC ROLLER SUPPORT

Figure 14b

2. Mark pipe/conduit to the desired length. Note that a 2" minimum distance from the end of the conduit to the bending mark is required to eliminate flattening the end of the pipe/conduit. See Figure 14c.

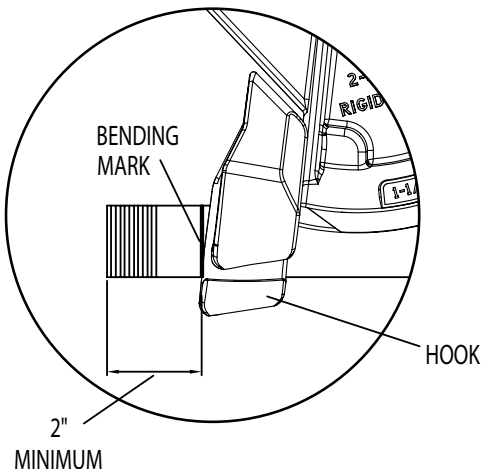

Figure 14c

NOTE: Stub-up and Offset dimensions can be found on the bending charts on pages 23 thru 26 of this manual or on the bending instruction decal located on the top of each bender.



BENDING INSTRUCTIONS FOR 1 1/2" AND 2" EMT & IMC CONDUIT – *continued*

3. Rotate the bending shoe to 10 degrees below the 0 (zero) degree setting. See Figure 12.
4. After marking the pipe/conduit, place it into the bender. The pipe/conduit should slide over the roller support and through the shoe groove and into the hook. The bending mark should be at the front (OUTSIDE) edge of the hook. See Figure 14c.

NOTE: The appropriate size and type of roller support **MUST** be used with the corresponding shoe size and type.

5. Step on the "Engaging Pedal" which will raise the rollers to come in contact with the conduit. See Figure 15. Be sure the correct rollers for the size conduit being bent are in position to engage the conduit.

NOTE: See SQUEEZE ADJUSTMENT PROCEDURE on page 17.

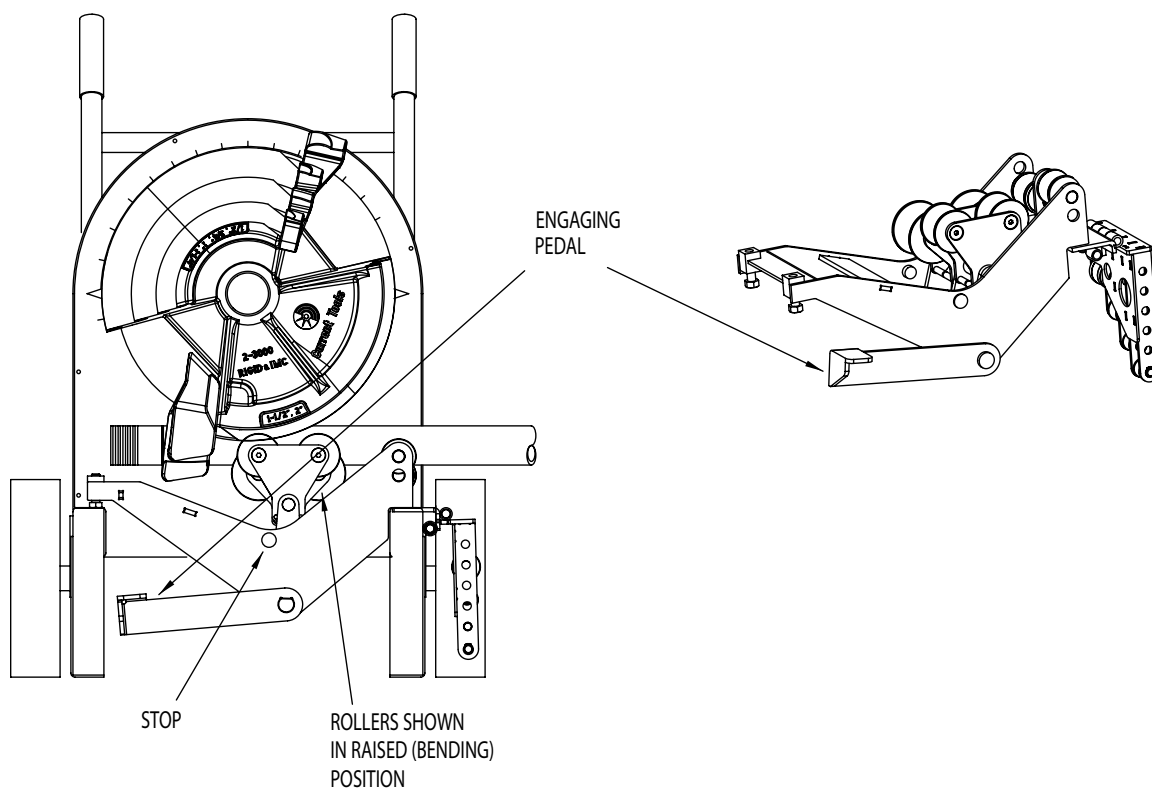

Figure 15



BENDING INSTRUCTIONS FOR 1 1/2" AND 2" EMT & IMC CONDUIT – *continued*

6. Keep foot pressure on the engaging pedal and push the “Bend/Unload” switch to the “*Bend*” position. Then press the “Jog” button. The conduit will pull the roller support against the stop. Foot pressure can then be removed from the engaging pedal. Be sure to check the alignment of the bending mark as the rotating shoe locks the conduit into position.

NOTE: If the roller support will not pull against the stop, the squeeze adjustment is too tight and will need to be adjusted. See squeeze adjustment procedure on page 17.

Advance the bender shoe to the desired degree of bend. When the pointer on the shoe reaches the desired degree of bend, release the “Jog” button and the bender will stop.

NOTE: Due to springback in pipe/conduit, some over bending is necessary to achieve the desired degree of bend. See page 24 or the bending instructions decal located on the top of each bender for approximate springback compensation figures.

NOTE: DO NOT allow the rollers to come in contact with the bending shoe. The shoe and rollers squeeze the conduit but they should never touch each other.

7. To release the pipe/conduit, place the “Bend/Unload” switch in the “*Unload*” position. Press the “Jog” button and reverse the shoe. The roller support will then drop, allowing removal of the conduit.



WARNING

The pipe/conduit should be under control when unloading.
Failure to do this may result in injury or death.

8. After removal of the conduit, inspect it for wrinkling or excessive side marks. If these conditions occur, refer to the SQUEEZE ADJUSTMENT PROCEDURE. See page 17.



SQUEEZE ADJUSTMENT PROCEDURE FOR 1 1/2" AND 2" EMT & IMC ROLLER SUPPORTS

The 1 1/2" and 2" rollers on the single shoe EMT Roller Support and the 1 1/2" and 2" rollers on the single shoe IMC Roller Support on the 77 bender have a Squeeze Adjustment feature if wrinkling or side marking becomes a problem during the bending process. This feature allows you to increase or decrease the amount of pressure applied to the conduit during bending, thereby eliminating these problems. Begin with the 7/8" starting location of the adjusting bolts as shown in Figure 17a.

1. If wrinkling occurs, pressure against the conduit during the bending process must increase. To increase the squeeze (pressure), loosen both set screws and turn both adjusting bolts one-half turn clockwise. Bend one piece of conduit to test the adjustment, and if wrinkling still occurs, repeat the procedure. Once you have achieved a good bend, tighten both set screws.

NOTE: Both adjusting bolts **MUST** be in contact with the bender leg. See Figure 17a.

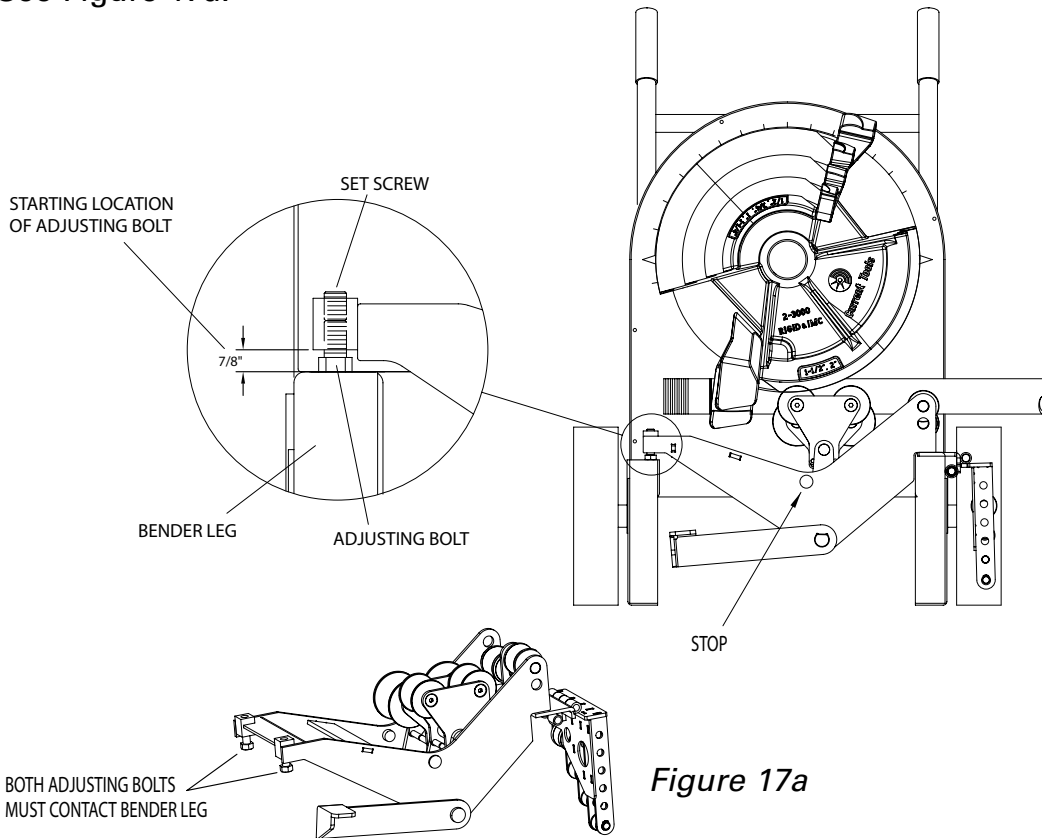

Figure 17a

2. If side marking occurs, pressure against the conduit during the bending process must be decreased. To decrease the squeeze (pressure), loosen both set screws and turn both adjusting bolts one-half turn counter-clock wise. Bend one piece of conduit to test the adjustment, if side marking still occurs, repeat the procedure. Once you have achieved a good bend, tighten both set screws.

NOTE: Both adjusting bolts **MUST** be in contact with the bender leg. See Figure 17a.

BENDING INSTRUCTIONS FOR 1/2" TO 1" ALUMINUM EMT

1. Mount the correct roller support for 1/2" thru 1" aluminum EMT conduit (part #2-4400) according to the instructions on page 10. See Figure 18a
2. Install the bending shoe (part #2-3100) as shown on page 11.
3. Use the roller support engaging pedal to lift the rollers. See Figure 18b.
4. Follow the General Bending Instructions beginning on page 12 to complete your bend.

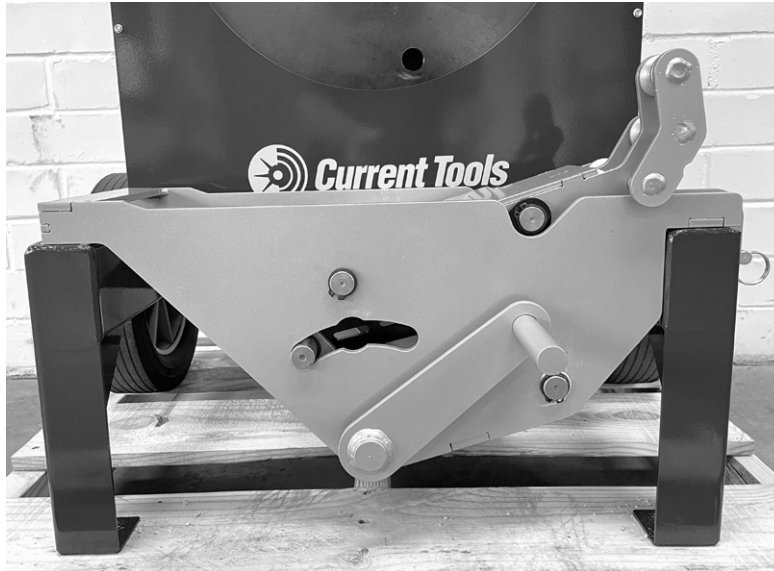

Figure 18a

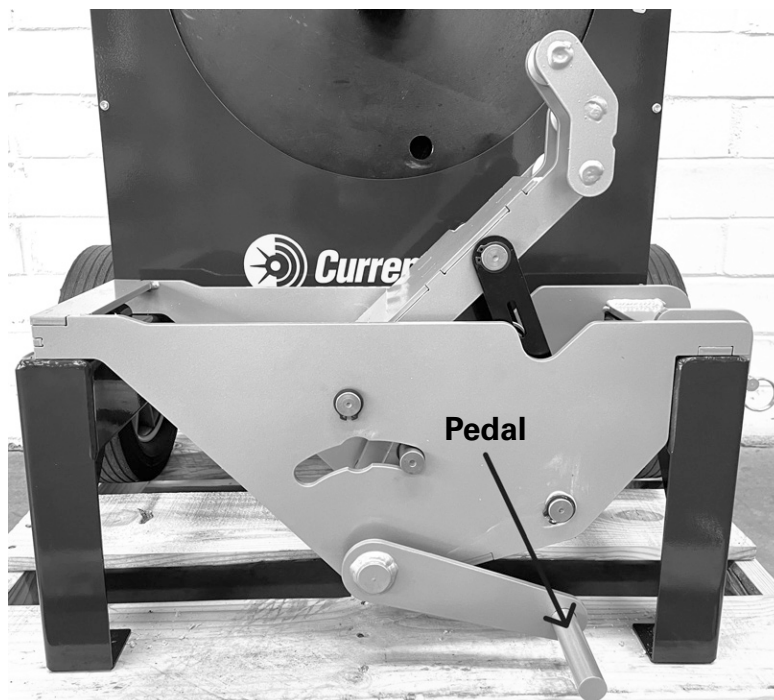

Figure 18b



BENDING INSTRUCTIONS FOR 1 1/4" AND 2" ALUMINUM EMT

1. Mount the correct roller support for 1 1/4" thru 2" aluminum EMT (part #2-4500) according to the instructions on page 10.
2. Use the roller support engaging pedal to lift the rollers. Locate the pull pin on the inside of the rollers and pull the pin to release the 1 1/4" and 2" set of rollers (see Fig. 19a). Rotate the 1 1/4" set of rollers until the pull pin fully engages the slot on the roller plate (see Fig. 19b). Install the bending shoe and follow the bending instructions in this manual for bending 1 1/2" and 2" EMT & IMC conduit, including squeeze adjustment procedures on page 17.

NOTE: Adjust the rollers to the 1 1/4" position BEFORE installing the bending shoe.



Figure 19a

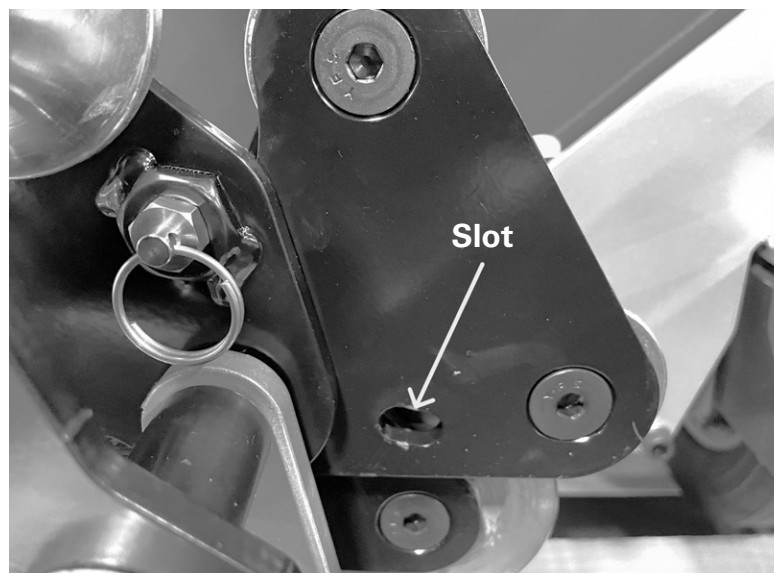

Figure 19b



BENDING INSTRUCTIONS FOR 1 1/2" AND 2" ALUMINUM EMT

1. Mount the correct roller support for 1 1/4" thru 2" aluminum EMT (part #2-4500) according to the instructions on page 10.
2. Use the roller support engaging pedal to lift the rollers. Locate the pull pin on the inside of the rollers and pull the pin to release the 1 1/4" and 2" set of rollers (see Fig. 20a). Rotate the 2" set of rollers until the pull pin fully engages the collar on the roller plate (see Fig. 20b). Install the bending shoe and follow the bending instructions in this manual for bending 1 1/2" and 2" EMT & IMC conduit, including squeeze adjustment procedures on page 17.

NOTE: Adjust the rollers to the 2" position BEFORE installing the bending shoe.



Figure 20a

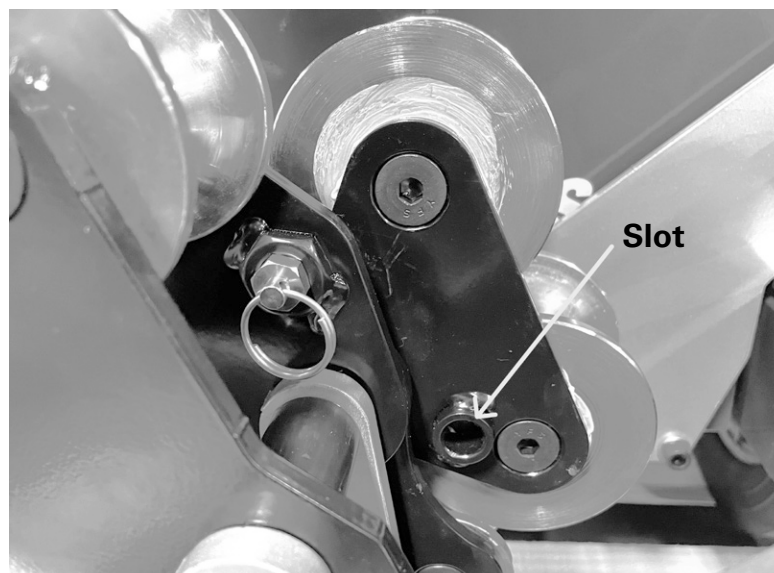

Figure 20b

WARNING

ALWAYS disconnect power supply before removing any guards or covers and before servicing this bender. Failure to do so may result in serious injury or death.

1. The Gear Box is filled with oil at the factory and should not require periodic flushing. If the Gear Box is opened for repair, flush by filling the unit with an AGMA #7 oil. Next, run the unit with no load for 3 minutes. Then, drain and refill the unit with 28 fluid ounces of an AGMA #7 oil such as the ones listed below.

Amoco – Amoco Worm Gear Oil

Chevron – Cylinder Oil 460X

Exxon – CYLESSTICTK460

Mobil – 600 W Cylinder Oil

Shell – Sun Gear Oil 7C

2. To inspect FRONT #60 chain tension:

- Remove front cover plate.
- To adjust, loosen hex bolt with 3/4 wrench and rotate chain tensioner toward chain as shown until chain moves no more than a total of 1/4". See Figure 21 below.
- Grease chain periodically with a good quality MP grease.

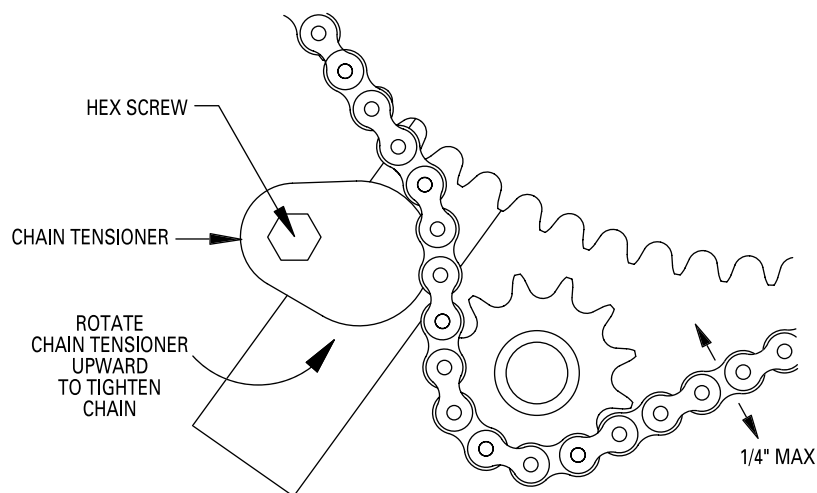

Figure 21

3. To inspect REAR #40 chain tension:

- Check chain tension after an initial break-in period of 2 - 3 hours of use and tighten per the instructions below. See Figure 22. Thereafter, inspect monthly.
- Remove the chain guard by taking out the 2 mounting screws.
- Loosen 8 bolts (4 on top and 4 on bottom) that hold the gear box in position.
- To tighten chain, move the gear box to the left and re-tighten bolts.
- For correct tension, chain should deflect approximately 1/8".

NOTE: Be sure to keep the gear box and motor in line with the bender.

- Grease chain periodically with a good quality MP grease.

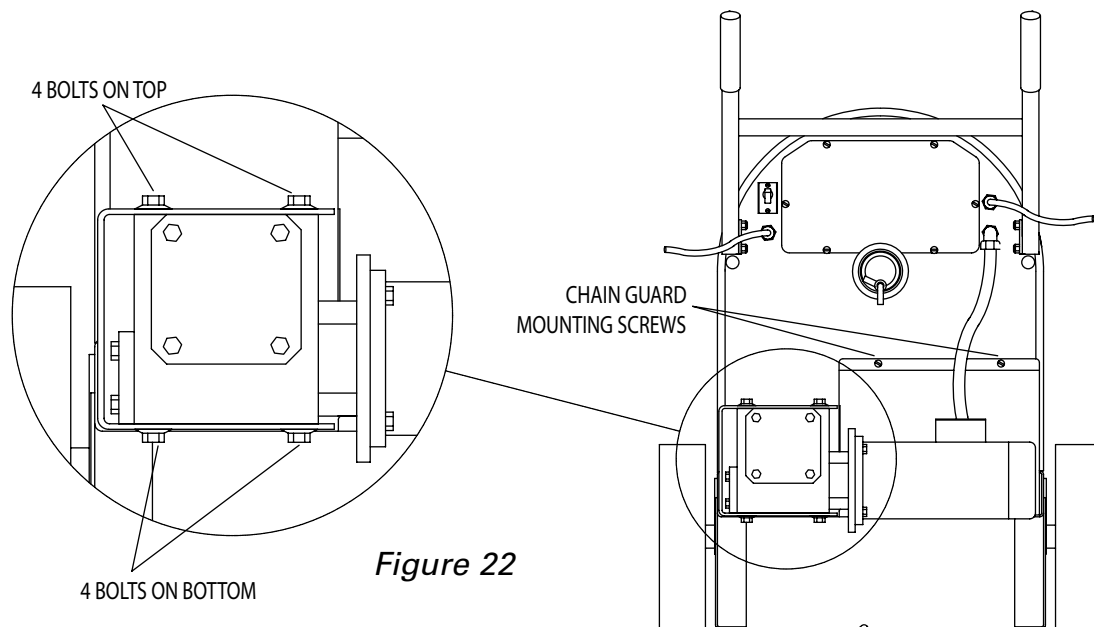

- Access to the gearbox sprocket is possible by removing access door as shown.

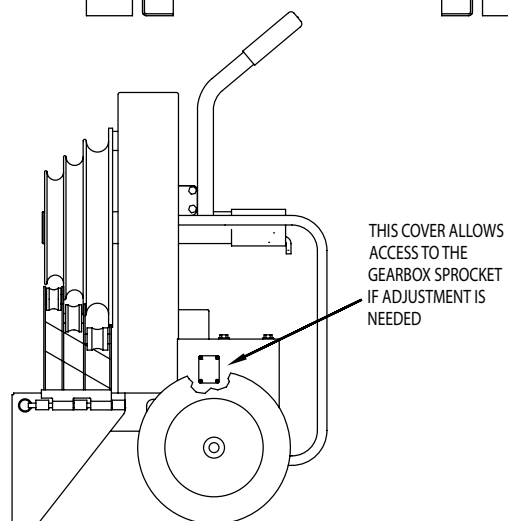



STUB-UP BENDING INFORMATION AND CHARTS — *continued*

To locate bending marks and springback of 15, 30, 45, 60, and 90 degree bends for a desired stub:

1. Check Chart A, B, C or C1 on Page 24 for deduct length. Note that minimum stub length is deduct length plus 2".
2. Measure and mark desired stub length on conduit (stub length mark). Subtract "Deduct Length" from this mark and make a second mark (bending mark). See Fig 23a and 23b. Place bending mark at front edge of shoe hook. See Figure 23c. Check Chart A, B, C or C1 on Page 24 for springback of desired degree of bend. Bender should be advanced to this degree to obtain desired degree of bend.

Figure 23a

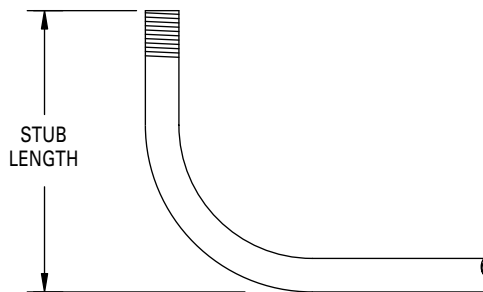

Figure 23b

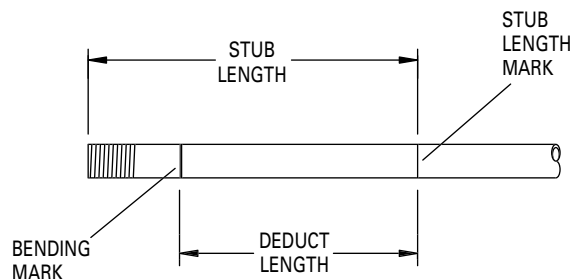
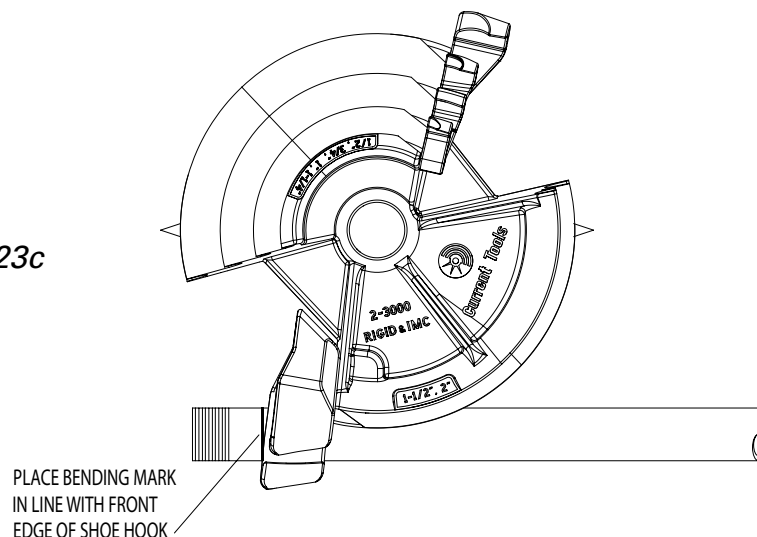

Figure 23c



**Chart A – RIGID Conduit/Schedule 40 Pipe**

Conduit Size	Deduct Length	Springback				
		15°	30°	45°	60°	90°
1/2"	7-1/2	17	33	49	64	96
3/4"	9	17	33	48	64	95
1"	11	17	32	48	63	94
1 1/4"	13-5/8	17	32	48	63	94
1 1/2"	14-7/8	17	32	48	63	94
2"	16-1/8	17	32	48	63	94

Chart B – EMT and Aluminum EMT

Conduit Size	Deduct Length	Springback				
		15°	30°	45°	60°	90°
1/2"	7-1/2	16	32	48	63	95
3/4"	9	17	33	48	64	95
1"	11	17	32	48	63	94
1 1/4"	13-5/8	17	32	48	63	94
1 1/2"	14-7/8	19	35	50	66	97
2"	16-3/8	19	34	50	65	96

Chart C – IMC Conduit

Conduit Size	Deduct Length	Springback				
		15°	30°	45°	60°	90°
1/2"	7-1/2	20	36	51	67	98
3/4"	9	19	35	50	66	97
1"	11	19	35	50	66	97
1 1/4"	13-5/8	19	35	50	66	97
1 1/2"	14-7/8	17	33	49	64	96
2"	16-1/8	19	34	50	65	96

Chart C1 – PVC Coated Rigid Conduit

Conduit Size	Deduct Length	Springback				
		15°	30°	45°	60°	90°
1/2"	7-1/2	16	31	47	62	93
3/4"	9	15	31	46	62	93
1"	11	16	32	47	63	94
1 1/4"	13-5/8	15	30	46	61	92
1 1/2"	14-7/8	18	33	49	64	95
2"	16-1/8	19	34	50	65	96

NOTE: Springback figures are approximate.

Minimum Stub Length = Deduct Length plus 2"



OFFSET BENDING INFORMATION AND CHARTS

To locate bending marks for a desired offset:

1. Measure distance from end of conduit to start of bend and mark conduit. (Mark 1) See Figure 25a and 25b.
2. Refer to chart E for measurement "X" (see page 26) and deduct this distance from Mark 1 and place Mark 2 on conduit. (See Figure 25b).
3. Refer to chart D (see page 26) for center-to-center distance between marks. Measure this distance from Mark 2 and place Mark 3 on conduit.
4. Layout of bends is now complete. Next, place Mark 2 in line with front edge of shoe hook and make first bend. (See Figure 25c).
5. Rotate conduit 180 degrees. Place Mark 3 in line with front edge of shoe hook and complete second bend.

Figure 25a

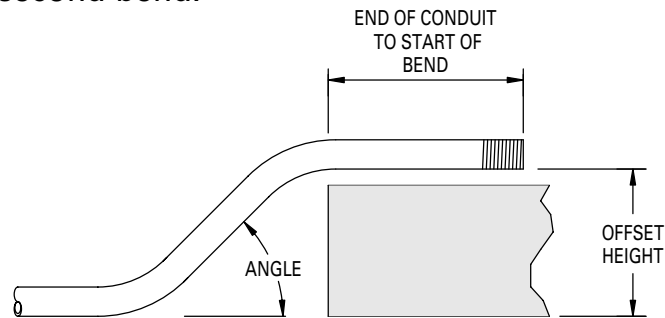

Figure 25b

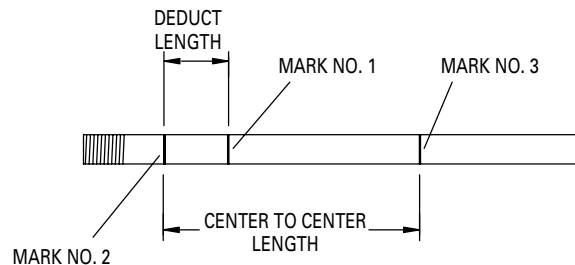
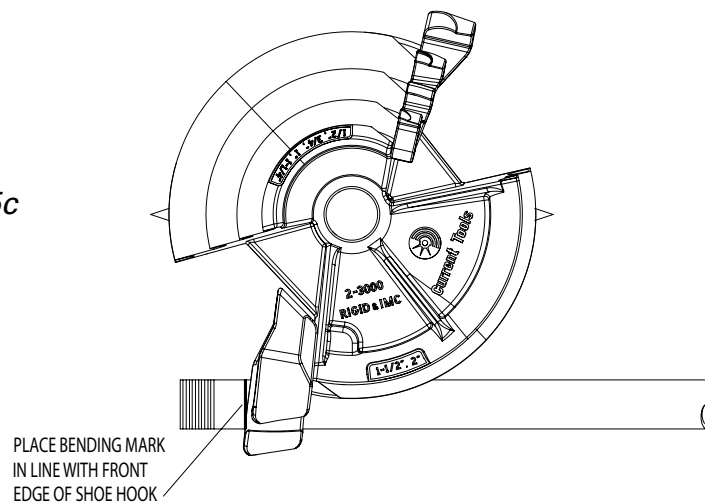

Figure 25c



**Chart D – Offset Height** *Figures are approximate.*

Offset Height		2	4	6	8	10	12	14	16	18	20	22
15°	Max Conduit Size	3/4"	1 1/2"	2"	2" and smaller							
	Center-to-Center	7 3/4"	15 7/16"	23 3/16"	30 15/16"	38 5/8"	46 3/8"	54 1/16"	61 13/16"	69 9/16"	77 1/4"	85"
30°	Max Conduit Size		3/4"	1"	1 1/2"	2"	2" and smaller					
	Center-to-Center		8"	12"	16"	20"	24"	28"	32"	36"	40"	44"
45°	Max Conduit Size			1/2"	1"	1 1/4"	1 1/2"	2"	2" and smaller			
	Center-to-Center			8 1/2"	11 5/16"	14 1/8"	16 15/16"	19 13/16"	22 5/8"	25 7/16"	28 1/4"	31 1/8"

To locate center-to-center distance of offset bending marks other than those listed in Chart D, use the following multipliers. Multiply the height of offset desired by 3.86 on 15 degree bends, 2 on 30 degree bends, and 1.4 on 45 degree bends.

Chart E *Figures are approximate.*

Conduit Size	1/2	3/4	1	1 1/4	1 1/2	2
"X"	3 1/16"	3 1/16"	3 3/16"	4"	4 1/4"	4 1/2"

! WARNING

ALWAYS disconnect power supply before removing any guards or covers and before servicing this bender. Failure to do so may result in serious injury or death.

Problem	Cause	Diagnosis	Cure
1. Bender will not operate	Power source	Check for voltage at power source	If power is on, go to (#3)
2. No power at bender	Bad power cord	Ohm cord for broken wire	Replace cord
3. Power to bender but will not operate	Circuit breaker / power switch in the off position	Check power on load side of breaker to neutral with volt meter	Turn circuit breaker on. If on, go to next step.
	Fuse #1 blown	Ohm circuit for short	Replace
	Control Transformer bad	Check voltage in and out, if input but no output	Replace
	Contactors bad	Check contacts and ohm coil for open circuit	Replace
	Bridge rectifier bad	Check with ohm meter	Replace
	Switch bad	Check with ohm meter	Replace
4. Motor runs but will not bend	Motor bad	Check brushes and ohm for open or short armature	Replace
	Chain from gear box to jack shaft broken	Remove cover and visually check for broken parts	Replace
	Bad gear box	Motor running but no output through gear box	Replace
	Chain from jack shaft to shoe sprocket broken	Remove cover and visually check for broken parts	Replace
5. Bender operates in one direction only	Key between motor and gear box missing	Remove motor from gear box	Replace key
	Bad FWD / REV switch	Ohm switch for open contact or shorted contacts	Replace
	Bad pendant cord	Ohm for broken wire	Replace
6. Contactors chatter	Bad contactor	Check contacts and ohm coil for open circuit	Replace
	Low power to bender	Check with amp meter	Do not use long drop cords

EXPLODED VIEWS

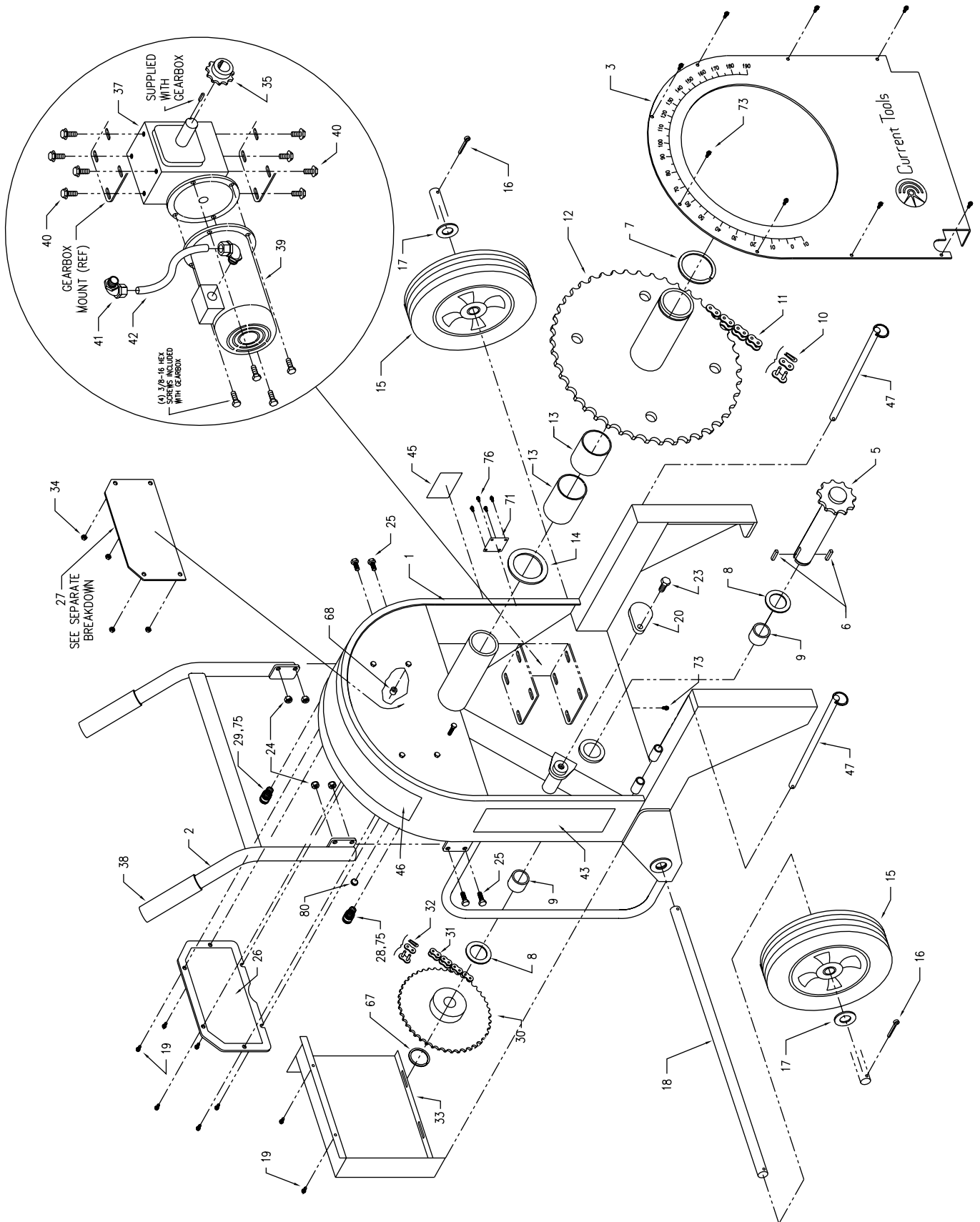

EXPLODED VIEWS – continued

**ELECTRICAL
PLATE**

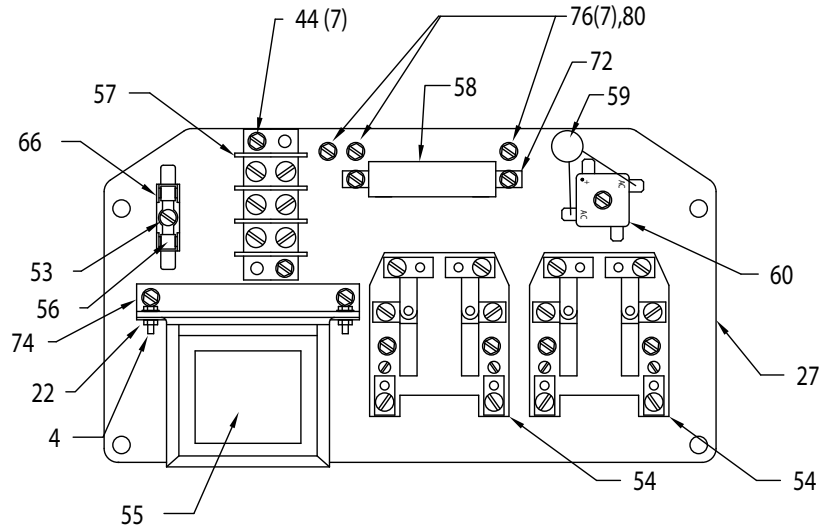

**CIRCUIT
BREAKER
SWITCH**

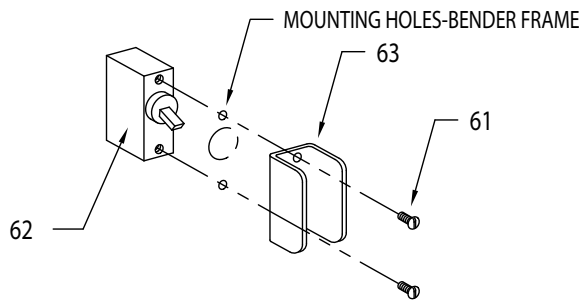

**REMOTE
PENDANT**

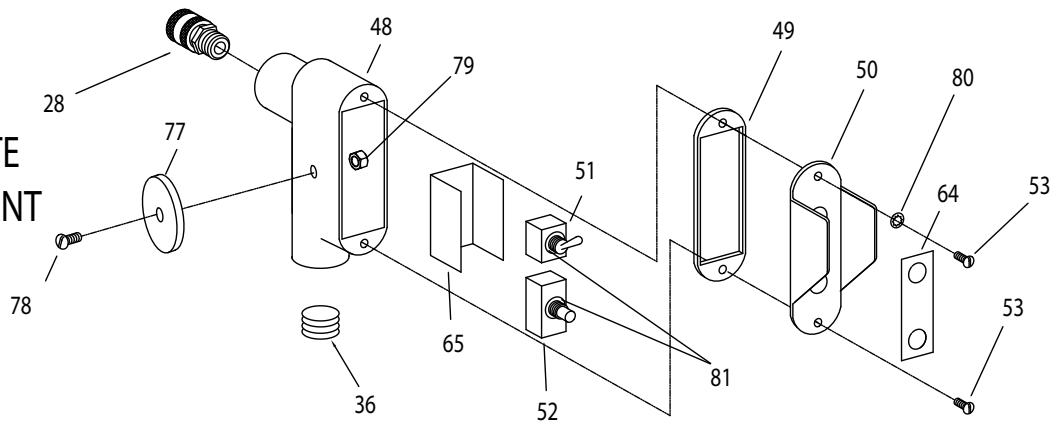



PARTS LIST – 77 SERIES ELECTRIC BENDER

ITEM #	PART #	QTY	DESCRIPTION
1	77-375	1	FRAME
2	77-346	1	HANDLE
3	77-004D	1	COVER
4	77-004	12	SCREW - #8-32 X 1/2" THD CUTTER
5	77-343	1	SPROCKET SHAFT
6	77-006A	2	KEY - SQUARE, 1/4" X 3/4" LONG
7	77-007	1	RETAINING RING - EXT, 2 1/2"
8	77-008	2	WASHER - PHENOLIC (JACKSHAFT)
9	77-009	2	SLEEVE BEARING
10	77-010	1	#60 MASTER LINK
11	77-011	1	#60 CHAIN
12	77-394	1	SPROCKET - MAIN DRIVE #60
13	77-070	2	SLEEVE - PHENOLIC
14	77-014	1	WASHER - PHENOLIC (MAIN)
15	77-015	2	WHEEL
16	77-016	2	PIN - COTTER, 3/16" X 1 1/4"
17	77-017	2	WASHER - 3/4" USS
18	77-429	1	AXLE
19	77-033A	9	SCREW - HEX, 10 X 1/2, #2 TEKS
20	77-413	1	CHAIN TENSIONER
22	453-16A	2	NUT - HEX #8 - 32
23	8092-2	1	SCREW - HEX 1/2 - 13 X 1"
24	2-1301-4	4	NUT - HEX, 5/16 - 18 (NYLON INS.)
25	77-002D1	4	SCREW - HEX 5/16 - 18 X 3/4
26	77-026	1	COVER - ELECTRICAL
27	77-339	1	PLATE - ELECTRICAL
28	77-028A	2	STRAIN RELIEF - PENDANT
29	77-028	1	STRAIN RELIEF - POWER CORD
30	77-288	1	SPROCKET - #40 B48
31	77-031	1	CHAIN - #40
32	77-032	1	MASTER LINK - #40
33	77-468	1	COVER - REAR CHAIN
34	9518SR-12	4	NUT - HEX, 1/4-20 (LOCK)
35	77-237	1	SPROCKET - #40 B13
36	77-3-1A	1	PLUG - PLASTIC
37	77-037	1	GEAR BOX
38	504-1	2	GRIP
39	77-039	1	MOTOR
40	77-040	8	BOLT - FLANGE LOCK, 3/8 - 16 X 3/4



PARTS LIST – *continued*

ITEM #	PART #	QTY	DESCRIPTION
41.....	77-041.....	2	FITTING - 90° LIQUITITE
42.....	77-042A.....	1	FLEX CONDUIT
43.....	77-043.....	1	DECAL - SAFETY INFORMATION
44.....	77-004B.....	7	SCREW - #8 - 32 X 5/8" THD CUTTER
45.....	77-045.....	1	SERIAL NUMBER PLATE
46.....	77-046.....	1	DECAL - BENDING INSTRUCTIONS
47.....	77-047.....	2	PIN - ROLLER SUPPORT
48.....	77-048.....	1	CONDULET - 1/2"
49.....	77-451.....	1	GASKET
50.....	77-128.....	1	GUARD - PENDANT SWITCH
51.....	77-051.....	1	SWITCH - FORWARD / REVERSE
52.....	77-052.....	1	SWITCH - JOG
53.....	77-072.....	3	SCREW - #8 - 32 X 1/2" RD. HD. PHILLIPS
54.....	77-054.....	2	CONTACTORS
55.....	77-055.....	1	TRANSFORMER - 24 VOLT
56.....	77-056.....	1	FUSE
57.....	77-057.....	1	TERMINAL BLOCK
58.....	77-058.....	1	RESISTOR
59.....	77-508.....	1	VARISTOR WITH WIRES
60.....	77-060.....	1	BRIDGE RECTIFIER
61.....	77-061.....	2	SCREW - PAN HD PHILLIPS, 6 -32 X 3/8"
62.....	77-062.....	1	CIRCUIT BREAKER
63.....	77-063.....	1	COVER - CIRCUIT BREAKER
64.....	77-064.....	1	DECAL - PENDANT
65.....	77-065.....	1	FISH PAPER - INSULATING
66.....	77-066.....	1	FUSE HOLDER
67.....	77-067.....	1	RETAINING RING
68.....	450-20.....	4	SPACER
69.....	77-068.....	1	CORD - POWER (not shown)
70.....	77-071.....	1	CORD - PENDANT (not shown)
71.....	77-714.....	1	ACCESS COVER
72.....	77-058A.....	2	BRACKET - RESISTOR (not shown)
73.....	452-6A.....	9	SCREW #8 X 1/2" SELF DRILL
74.....	77-387.....	1	BRACKET - TRANSFORMER
75.....	77-041A.....	2	NUT - 1/2" LOCK
76.....	77-004A.....	11	SCREW - #8 - 32 X 3/8" THD CUTTER
77.....	747-19.....	1	MAGNET
78.....	451-22.....	1	SCREW - PAN HD PHILLIPS, 10-32 X 3/8"
79.....	451-21.....	1	NUT HEX 10 - 32 (NYLON INSERT)
80.....	747-39.....	1	WASHER, LOCK - #8 EXT. TOOTH
81.....	747-40.....	2	WASHER, LOCK - 15/32" INT. TOOTH

ELECTRICAL SYSTEM DIAGRAM

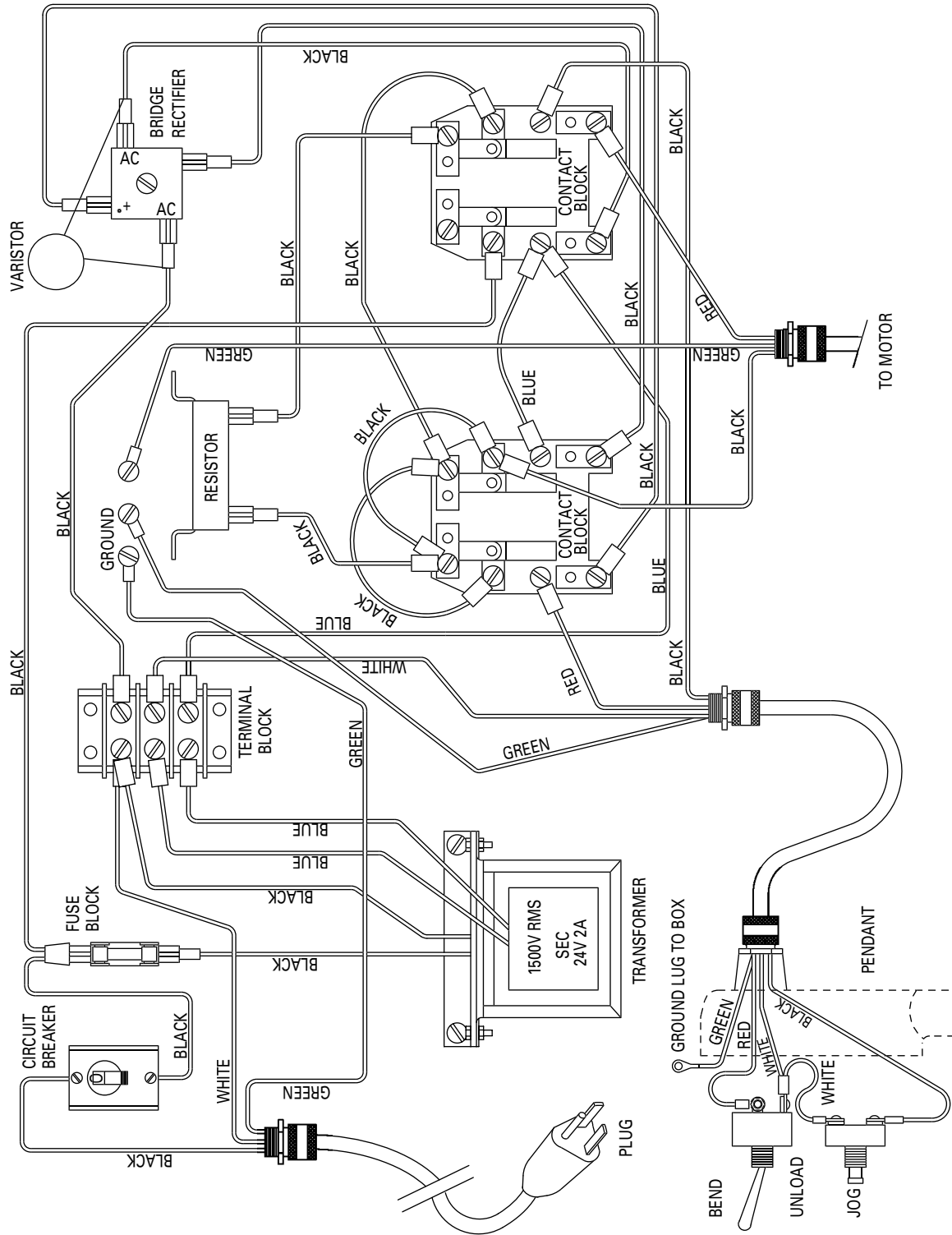



PARTS LIST – SINGLE SHOES & ROLLER SUPPORTS

**2-3000 & 2-4000 Bending Shoe & Roller Support –
1/2" to 2" RIGID Conduit AND Schedule 40 pipe
1/2" to 1 1/4" IMC conduit**

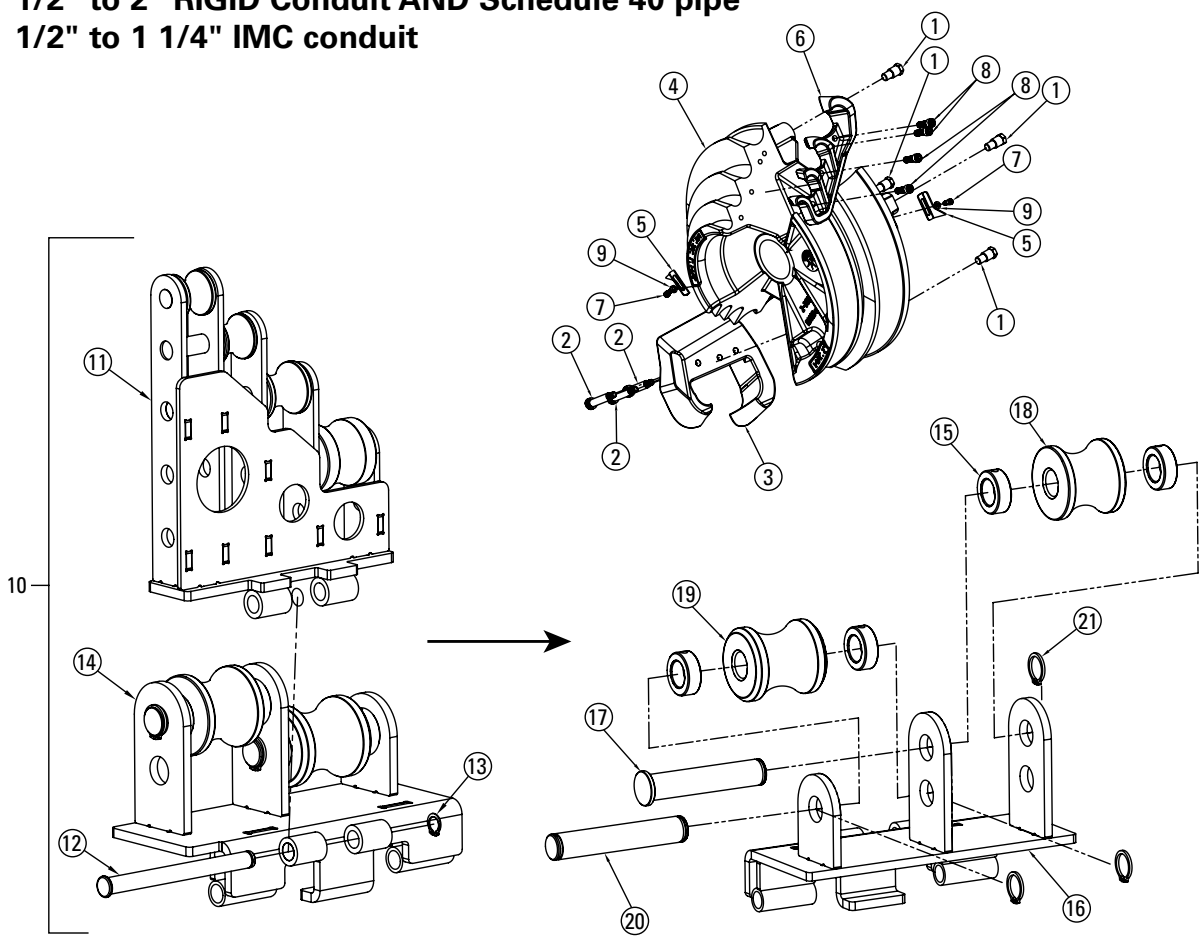

ITEM #	PART #	QTY	DESCRIPTION
1	2-1304	4	DRIVE STUD
2	2-2301-2	3	SCREW, SHOULDER SOCKET – 3/4" x 1 1/2"
3	2-2302	1	HOOK, 1 1/2"-2" RIGID/IMC
4	2-3000-101	1	SHOE – 1/2"-2" RIGID/IMC
5	2-3000-102	2	POINTER – DEGREE INDICATOR
6	2-3002	1	HOOK, 1/2"-1 1/4" RIGID/IMC
7	99-8	2	SCREW, SKT. HD. CAP – 1/4-20 x 1/2"
8	99-59	4	SCREW, SKT. HD. CAP – 3/8-16 x 1 1/4"
9	450-14G	2	WASHER, LOCK 1/4"
10	2-4000	1	ROLLER SUPPORT – 1/2" TO 2" RIGID AND 1/2" TO 1 1/4" IMC
11	2-4000-107A	1	ROLLER SUPPORT ASSEMBLY – 1/2" TO 1 1/4"
12	2-4000-122	1	HINGE PIN
13	2-4000-123	1	RETAINING RING – 7/16"
14	2-4000-125	1	ROLLER SUPPORT ASSEMBLY – 1 1/2" TO 2"
15	2-4000-001	4	COLLAR, 3/4" I.D. – 1 1/2"-2" ROLLER
16	2-4000-106A	1	WELDMENT – 1 1/2"-2" ROLLER SUPPORT
17	747-892	1	PIN – HEADED, 3/4"
18	2-4000-126	1	ROLLER – 1 1/2" RIGID
19	2-4000-127	1	ROLLER – 2" RIGID
20	2-4100-126	2	PIN – 3/4" DIA. FOR 2" ROLLER
21	2-1109	3	RING – RETAINING, 3/4"



PARTS LIST – SINGLE SHOES & ROLLER SUPPORTS

**2-3200 & 2-4300
Bending Shoe & Roller Support –
1/2" to 2" PVC Coated RIGID Conduit**

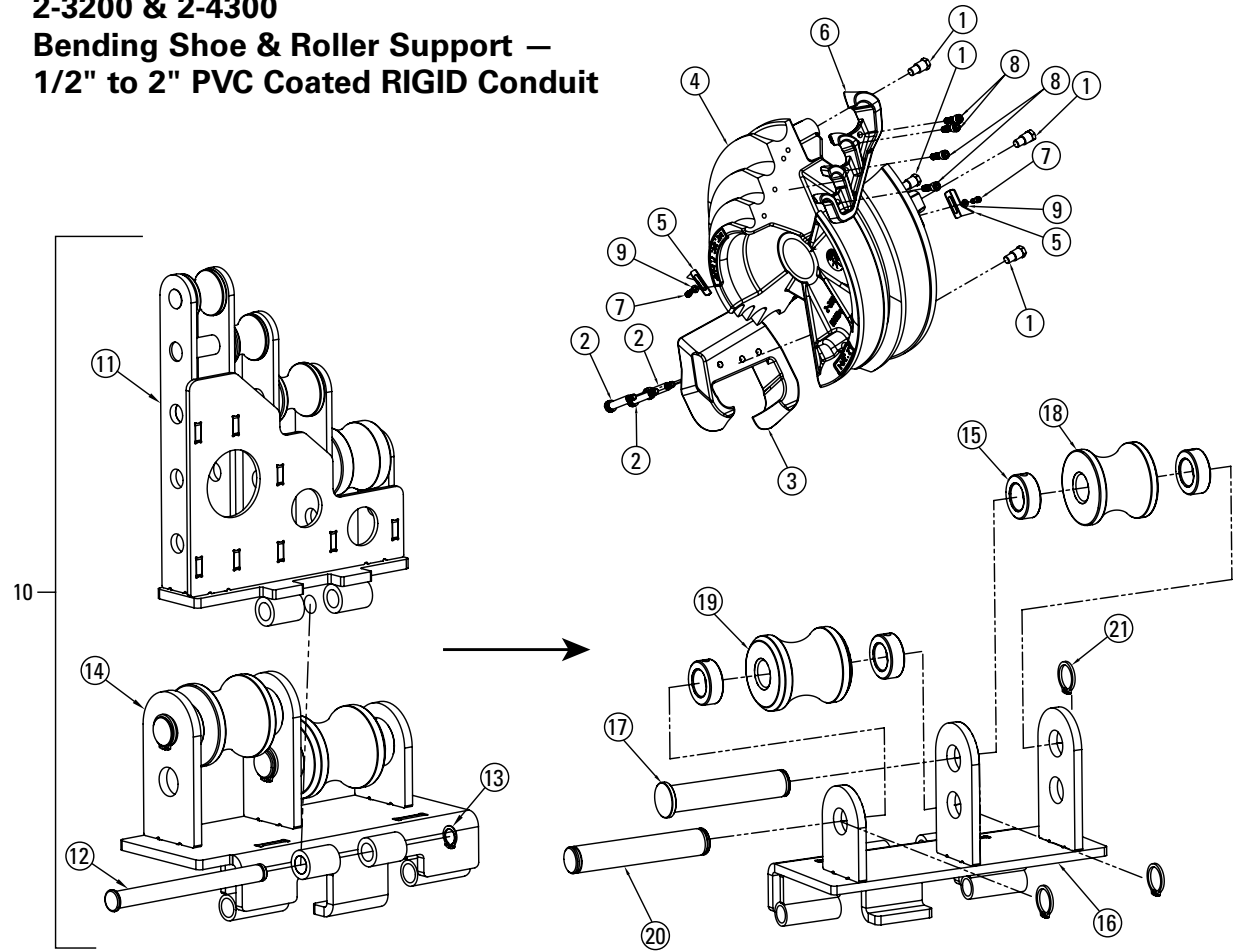

ITEM #	PART #	QTY	DESCRIPTION
1.....	2-1304	4	DRIVE STUD
2.....	2-2301-2	3	SCREW, SHOULDER SOCKET – 3/4 x 1 1/2"
3.....	2-3203	1	HOOK, 1 1/2"-2" PVC COATED RIGID
4.....	2-3200-101	1	SHOE – 1/2"-2" PVC COATED RIGID
5.....	2-3000-102	2	POINTER – DEGREE INDICATOR
6.....	2-3202	1	HOOK, 1/2"-1 1/4" PVC COATED RIGID
7.....	99-8	2	SCREW, SKT. HD. SKT. – 1/4-20 x 1/2"
8.....	99-59	4	SCREW, SKT. HD. CAP – 3/8-16 x 1 1/4"
9.....	450-14G	2	WASHER, LOCK 1/4"
10.....	2-4300	1	ROLLER SUPPORT – 1/2" TO 2" PVC COATED RIGID
11.....	2-4000-107B	1	ROLLER SUPPORT ASSEMBLY – 1/2" TO 1 1/4"
12.....	2-4000-122	1	HINGE PIN
13.....	2-4000-123	1	RETAINING RING – 7/16"
14.....	2-4300-103	1	ROLLER SUPPORT ASSEMBLY – 1 1/2" TO 2"
15.....	2-4000-001	4	COLLAR, 3/4" I.D. – 1 1/2"-2" ROLLER
16.....	2-4000-106B	1	WELDMENT – 1 1/2"-2" ROLLER SUPPORT
17.....	747-892	1	PIN – HEADED, 3/4"
18.....	2-1005A	1	ROLLER – 1 1/2" PVC COATED RIGID
19.....	2-1005B	1	ROLLER – 2" PVC COATED RIGID
20.....	2-4100-126	1	PIN – 3/4" DIA. FOR 2" ROLLER
21.....	2-1109	3	RING – RETAINING, 3/4"

PARTS LIST – SINGLE SHOES & ROLLER SUPPORTS

2-3100 Bending Shoe 1/2" to 2" EMT Conduit

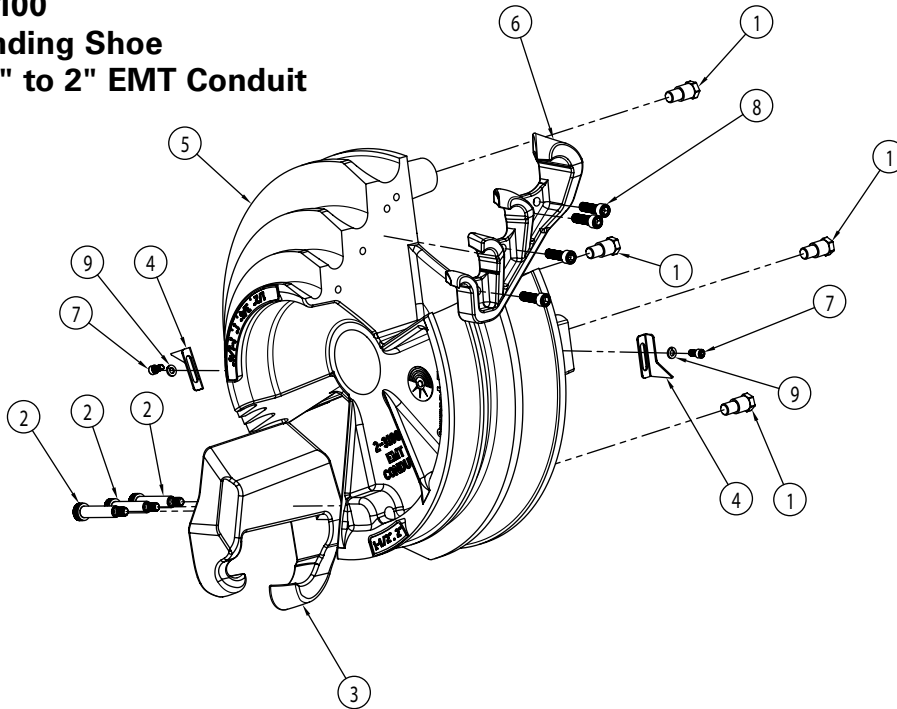

ITEM #	PART #	QTY	DESCRIPTION
1.....	2-1304.....	4.....	DRIVE STUD
2.....	2-2301-2.....	3.....	SCREW, SHOULDER SOCKET – 3/4" x 1 1/2"
3.....	2-2303.....	1.....	HOOK, 1 1/2"-2 EMT
4.....	2-3000-102.....	2.....	POINTER – DEGREE INDICATOR
5.....	2-3100-101.....	1.....	SHOE – 1/2"-2" EMT
6.....	2-3102.....	1.....	HOOK, 1/2"-1 1/4" EMT
7.....	99-8.....	2.....	SCREW, SKT. HD. CAP – 1/4-20 x 1/2"
8.....	99-59.....	4.....	SCREW, SKT. HD. CAP – 3/8-16 x 1 1/4"
9.....	450-14G.....	2.....	WASHER, LOCK 1/4"



PARTS LIST – SINGLE SHOES & ROLLER SUPPORTS

2-4200 Roller Support 1/2" to 2" EMT Conduit

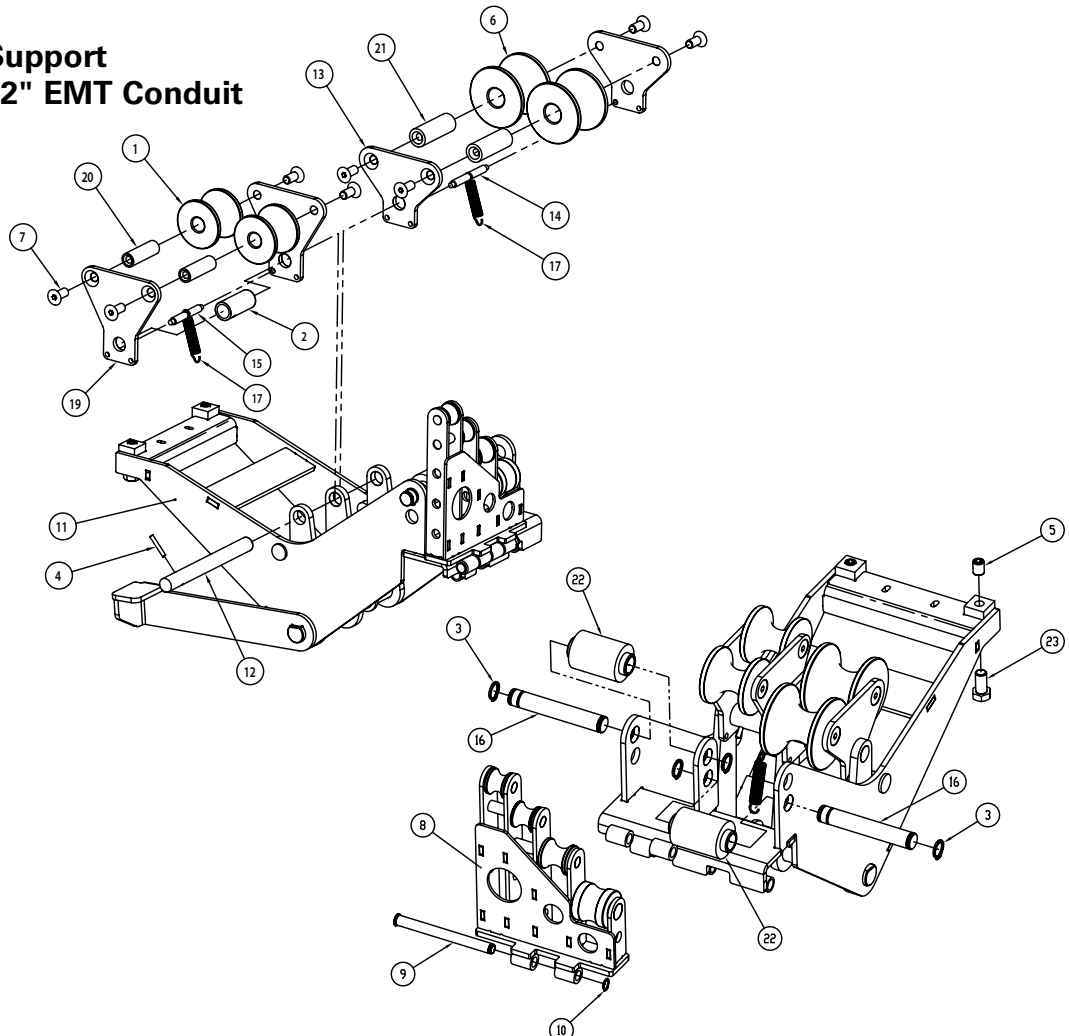

ITEM #	PART #	QTY.	DESCRIPTION
1	2-1103	2	ROLLER - 1.5" EMT
2	2-1108	1	SPACER TUBE
3	2-1109	4	3/4" RETAINER RING
4	2-1111	1	.187" DIA. X 1.25 LG ROLL PIN
5	2-1112	2	1/2-13 X .75 LG SET SCREW - CONE PT
6	2-1116	2	ROLLER - 2" EMT
7	2-1118	8	.7/16-14 X 1.00 LG FHCS
8	2-4000-107D	1	1/2" - 1.25" EMT ROLLER SUPPORT
9	2-4000-122	1	HINGE PIN, UPPER
10	2-4000-123	1	7/16" RETAINER RING
11	2-4100-107D	1	EMT ROLLER SUPPORT FRAME
12	2-4100-118	1	AXLE, ROLLER BRACKET
13	2-4100-119	2	BRACKET - 2" ROLLER
14	2-4100-121	1	SPRING CLIP, 2.00" ROLLER
15	2-4100-122	1	SPRING CLIP, 1.50" ROLLER
16	2-4100-123	2	3/4" DIA. PIN, 1.50" - 2.00" ROLLER
17	2-4100-124	2	SPRING
18	2-4200-1	1	DECAL (NOT SHOWN)
19	2-4200-101	2	BRACKET, 1.50" EMT ROLLER
20	747-858	2	ROLLER PIN 1.50"
21	747-859	2	ROLLER PIN 2.00"
22	747-894	2	ROLLER - URETHANE
23	8092-2	2	SCREW-HEX HEAD CAP GR5 ZINC (1/2-13 X 1)



PARTS LIST – SINGLE SHOES & ROLLER SUPPORTS

2-3000
Bending Shoe
1/2" to 2" IMC Conduit

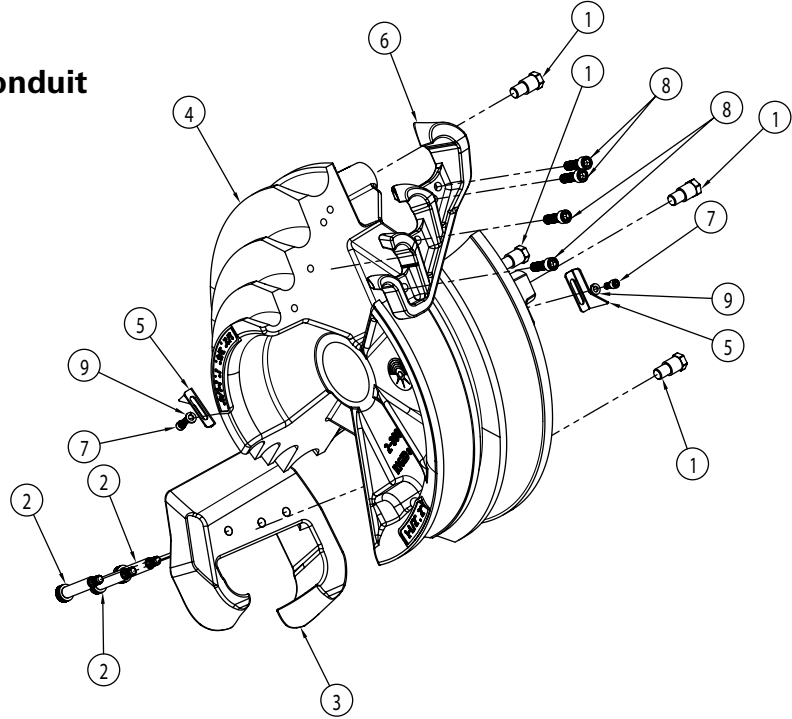

<u>ITEM #</u>	<u>PART #</u>	<u>QTY</u>	<u>DESCRIPTION</u>
1.....	2-1304.....	4.....	DRIVE STUD
2.....	2-2301-2.....	3.....	SCREW, SHOULDER SOCKET – 3/4" x 1 1/2"
3.....	2-2302.....	1.....	HOOK, 1 1/2"-2 RIGID/IMC
4.....	2-3000-101.....	1.....	SHOE – 1/2"-2" RIGID/IMC
5.....	2-3000-102.....	2.....	POINTER – DEGREE INDICATOR
6.....	2-3002.....	1.....	HOOK, 1/2"-1 1/4" RIGID/IMC
7.....	99-8.....	2.....	SCREW, SKT. HD. CAP – 1/4-20 x 1/2"
8.....	99-59.....	4.....	SCREW, SKT. HD. CAP – 3/8-16 x 1 1/4"
9.....	450-14G.....	2.....	WASHER, LOCK 1/4"



PARTS LIST – SINGLE SHOES & ROLLER SUPPORTS

2-4100 Roller Support – 1/2" to 2" IMC Conduit

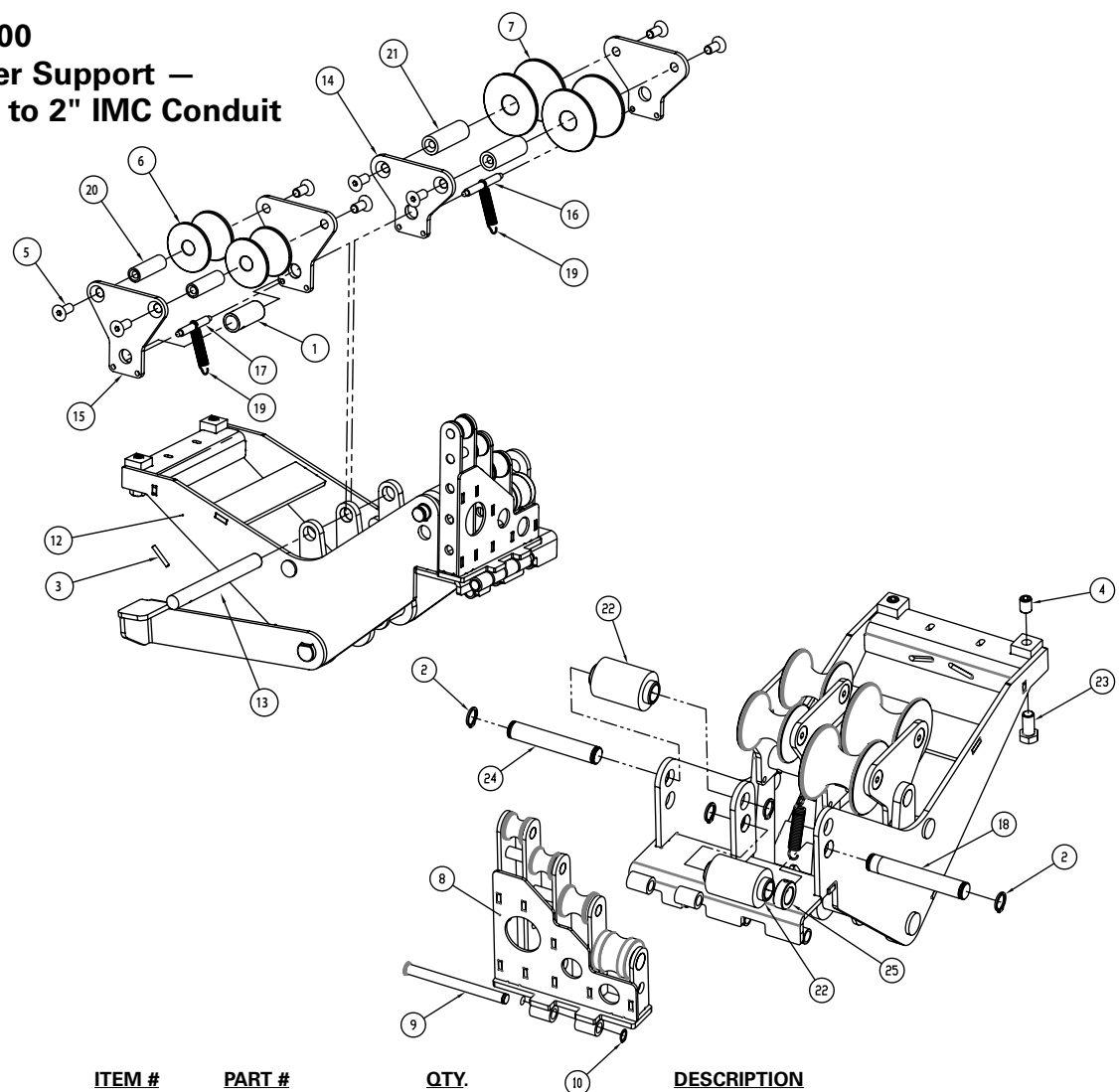

ITEM #	PART #	QTY.	DESCRIPTION
1	2-1108	1	SPACER TUBE
2	2-1109	4	3/4" RETAINER RING
3	2-1111	1	.187" DIA. X 1.25 LG ROLL PIN
4	2-1112	2	1/2-13 X .75 LG SET SCREW - CONE PT
5	2-1118	8	7/16-14 X 1.00 LG FHCS
6	2-1204	2	1.50" IMC ROLLER
7	2-1205	2	2.00" IMC ROLLER
8	2-4000-107C	1	.50" - 1.25" IMC ROLLER SUPPORT
9	2-4000-122	1	HINGE PIN, UPPER
10	2-4000-123	1	7/16" RETAINER RING
11	2-4100-1	1	DECAL (NOT SHOWN)
12	2-4100-107C	1	IMC ROLLER SUPPORT FRAME
13	2-4100-118	1	AXLE, ROLLER BRACKET
14	2-4100-119	2	BRACKET, 2.00" ROLLER
15	2-4100-120	2	BRACKET, 1.50" IMC ROLLER
16	2-4100-121	1	SPRING CLIP, 2.00" ROLLER
17	2-4100-122	1	SPRING CLIP, 1.50" ROLLER
18	2-4100-123	2	.75" PIN, FOR 2" ROLLER
19	2-4100-124	2	SPRING
20	747-858	2	ROLLER PIN 1.50"
21	747-859	2	ROLLER PIN 2.00"
22	747-894	2	ROLLER - URETHANE
23	8092-2	2	SCREW-HEX HEAD CAP GR5 ZINC (1/2-13 X 1)
24	2-4100-126	1	.75" PIN FOR 1 1/2" ROLLER
25	2-4000-001	1	.75" I.D. COLLAR



PARTS LIST – SINGLE SHOES & ROLLER SUPPORTS

2-4400 Roller Support – 1/2" to 1" Aluminum EMT Conduit

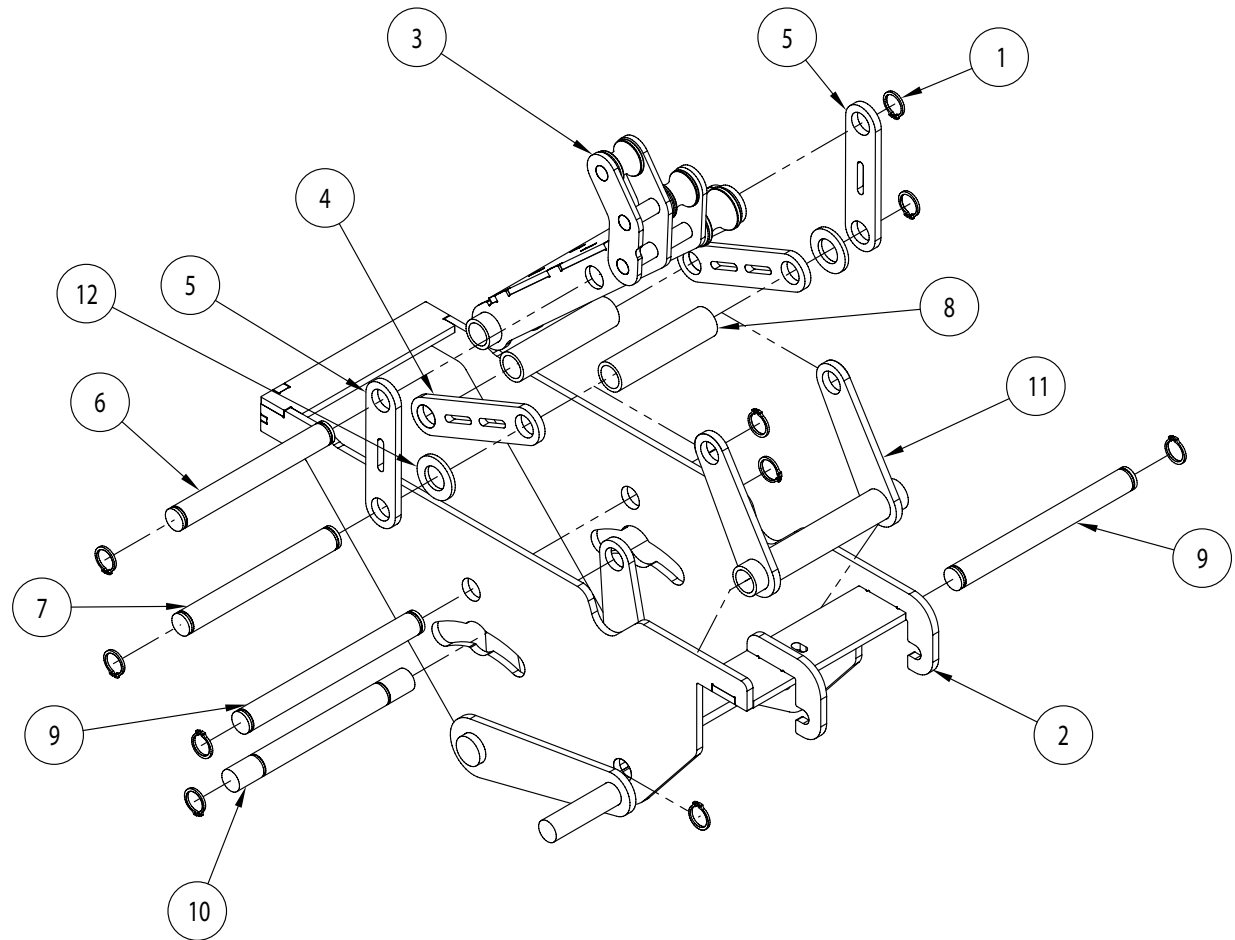

ITEM #	PART #	QTY.	DESCRIPTION
1.....	2-1109.....	4.....	3/4" RETAINER RING
2.....	2-1111.....	1.....	PIN-ROLL 3/16" x 1.25"
3.....	2-1112.....	2.....	SCREW-SET CUP PT (1/2-13 x 3/4)
4.....	2-1301-4.....	1.....	NUT-HEX NYLON INSERT (5/16"-18)
5.....	2-4100-118.....	1.....	ROLLER SUPPORT AXLE
6.....	2-4100-123.....	1.....	.75" ~ PIN, 2.00" ROLLER
7.....	2-4100-124.....	1.....	SUPPORT SPRING
8.....	2-4500-102.....	1.....	ROLLER SUPPORT FRAME
9.....	2-4500-104.....	1.....	ROLLER ASSEMBLY, 1-1/4"
10.....	2-4000-123.....	1.....	.7/16" RETAINER RING
11.....	2-4500-108.....	1.....	ROLLER ASSEMBLY, 1-1/2"
12.....	2-4500-115.....	1.....	ROLLER ASSEMBLY, 2"
13.....	2-4500-116.....	1.....	SPACERTUBE
14.....	77-025.....	2.....	SCREW-HEX HEAD CAP GR5 (1/2-13 x 1.25)
15.....	254-001.....	1.....	.5/16-18 X .75 SHCS
16.....	412-11.....	1.....	WASHER-LOCK MEDIUM 5/16 ZINC
17.....	747-894.....	2.....	ROLLER-1-1/2" EMT

PARTS LIST – SINGLE SHOES & ROLLER SUPPORTS

2-4500 Roller Support – 1 1/4" to 2" Aluminum EMT Conduit

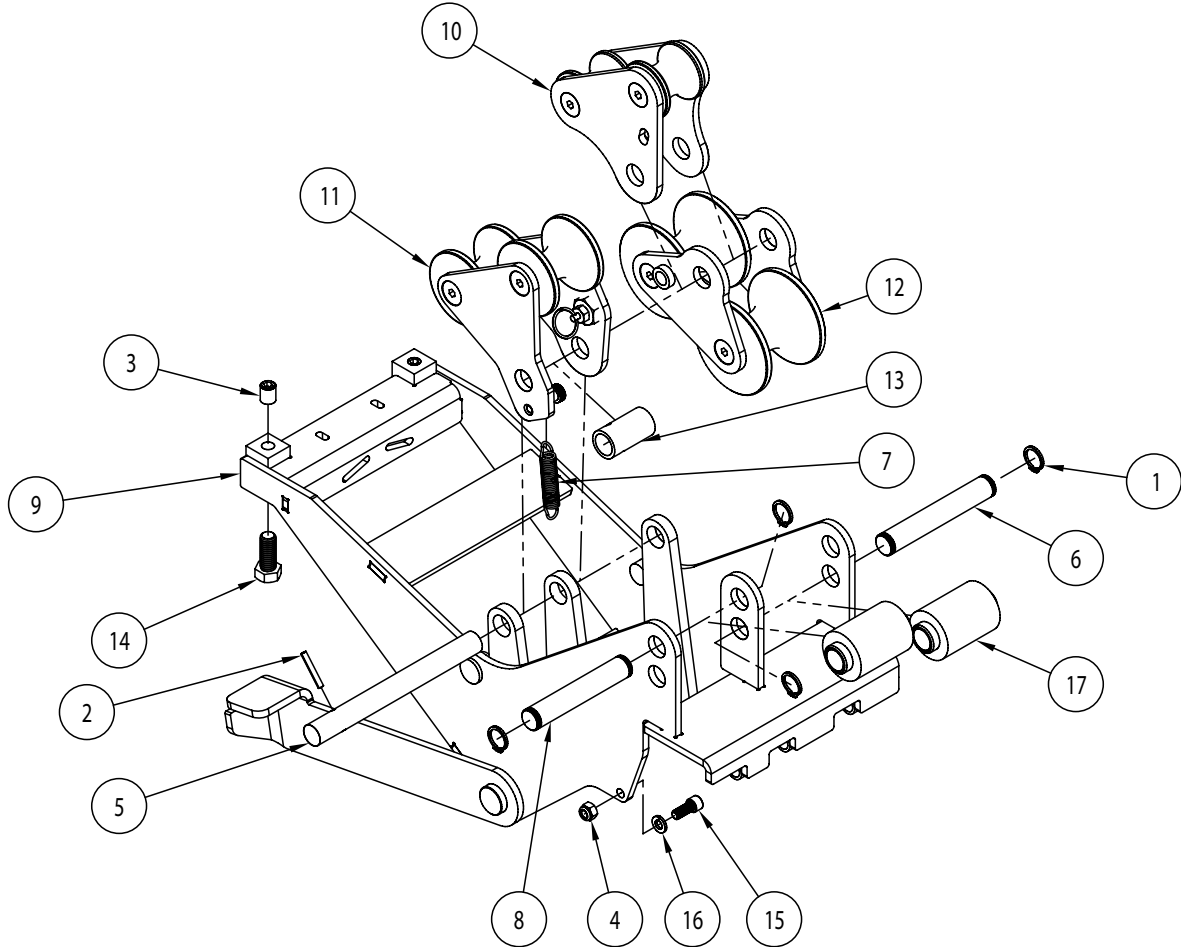

ITEM #	PART #	QTY.	DESCRIPTION
1	2-1109	4	3/4" RETAINER RING
2	2-1111	1	PIN-ROLL 3/16" x 1.25"
3	2-1112	2	SCREW-SET CUP PT (1/2-13 x 3/4)
4	2-1301-4	1	NUT-HEX NYLON INSERT (5/16"-18)
5	2-4100-118	1	ROLLER SUPPORT AXLE
6	2-4100-123	1	.75" ~ PIN, 2.00" ROLLER
7	2-4100-124	1	SUPPORT SPRINGER
8	2-4100-126	1	PIN - 1.50" ROLLER
9	2-4500-102	1	ROLLER SUPPORT FRAME
10	2-4500-104	1	ROLLER ASSEMBLY, 1-1/4"
11	2-4500-108	1	ROLLER ASSEMBLY, 1-1/2"
12	2-4500-115	1	ROLLER ASSEMBLY, 2"
13	2-4500-116	1	SPACERTUBE
14	77-025	2	SCREW-HEX HEAD CAP GR5 (1/2-13 x 1.25)
15	254-001	1	5/16-18 X .75 SHCS
16	412-11	1	WASHER-LOCK MEDIUM 5/16 ZINC
17	747-894	2	ROLLER-1-1/2" EMT



PARTS LIST – SINGLE SHOES & ROLLER SUPPORTS

2-4500-104 Roller Assembly for 1 1/4"

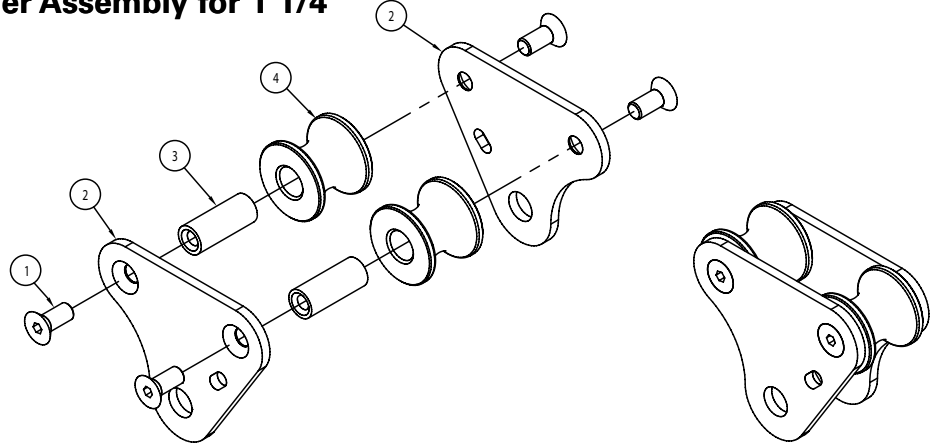

<u>ITEM #</u>	<u>PART #</u>	<u>QTY.</u>	<u>DESCRIPTION</u>
1.....	2-1118.....	4.....	SCREW - FLAT SOCKET (7/16-14 x 1)
2.....	2-4500-103.....	2.....	SIDE PLATE - 1-1/4
3.....	2-4500-105.....	2.....	ROLLER PIN - 1-1/4"
4.....	2-4500-121.....	2.....	ROLLER - 1-1/4" EMT

2-4500-104 Roller Assembly for 1 1/2"

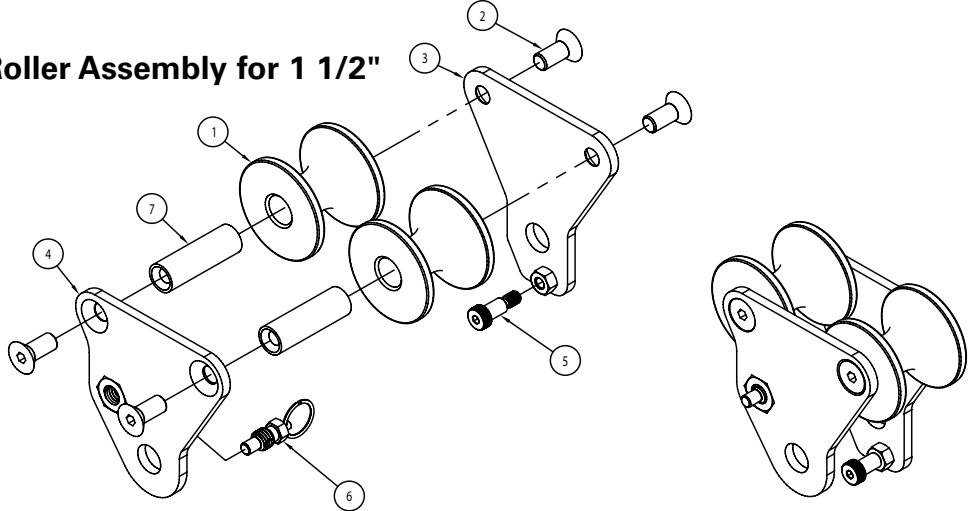

<u>ITEM #</u>	<u>PART #</u>	<u>QTY.</u>	<u>DESCRIPTION</u>
1.....	2-1103.....	2.....	ROLLER-1-1/2" EMT x 1
2.....	2-1118.....	4.....	SCREW - FLAT SOCKET (7/16-14 x 1)
3.....	2-4500-109.....	1.....	FRONT PLATE WELDMENT - 1-1/2"
4.....	2-4500-110.....	1.....	BACK PLATE WELDMENT - 1-1/2"
5.....	77HRB-003.....	1.....	SCREW-SHOULDER SOCKET (3/8" x 5/8")
6.....	747-2.....	1.....	PLUNGER-SPRING
7.....	747-858.....	2.....	ROLLER PIN - 1-1/2"



PARTS LIST – SINGLE SHOES & ROLLER SUPPORTS

2-4500-104 Roller Assembly for 2"

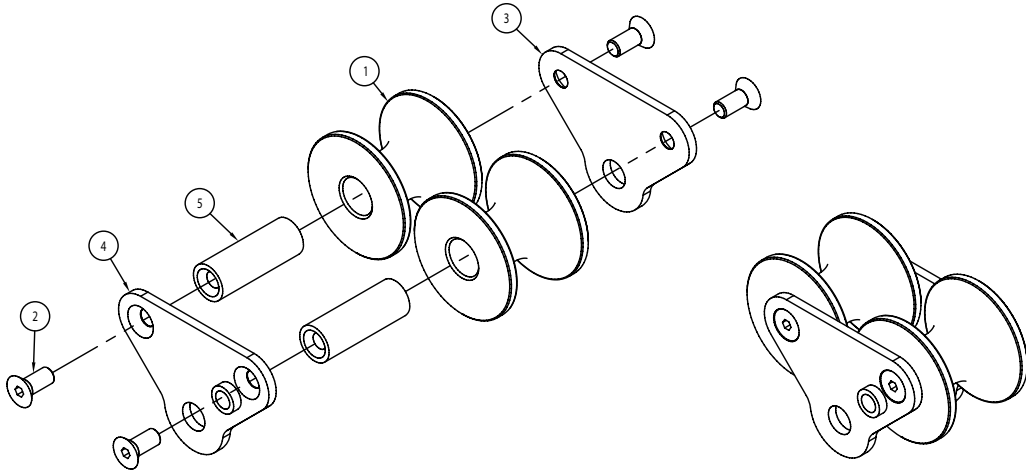

<u>ITEM #</u>	<u>PART #</u>	<u>QTY.</u>	<u>DESCRIPTION</u>
1.....	2-1116.....	2.....	ROLLER - 2" EMT
2.....	2-1118.....	4.....	SCREW - FLAT SOCKET (7/16-14 x 1)
3.....	2-4500-112.....	1.....	BACK PLATE - 2"
4.....	2-4500-114.....	1.....	FRONT PLATE WELDMENT - 2"
5.....	747-859.....	2.....	ROLLER PIN - 2"